



**Auditor of State  
Betty Montgomery**



**FINANCIAL CONDITION  
MIAMI COUNTY**

**TABLE OF CONTENTS**

<b>TITLE</b>	<b>PAGE</b>
Schedule of Federal Awards Expenditures for the Year Ended December 31, 2004.....	1
Notes to the Schedule of Federal Award Expenditures .....	4
Independent Accountants' Report on Internal Control Over Financial Reporting And on Compliance and Other Matters Required by <i>Government Auditing Standards</i> .....	5
Independent Accountants' Report on Compliance with Requirements Applicable to Each Major Federal Program and Internal Control Over Compliance in Accordance with OMB Circular A-133 .....	7
Schedule of Findings and Questioned Costs.....	9
Corrective Action Plan.....	12

**This page intentionally left blank.**

**FINANCIAL CONDITION  
MIAMI COUNTY**

**SCHEDULE OF FEDERAL AWARD EXPENDITURES  
FOR YEAR ENDED DECEMBER 31, 2004**

<b>Federal Grantor / Pass Through Grantor Program Title</b>	<b>Pass Through Entity Number</b>	<b>CFDA Number</b>	<b>Disbursements</b>	<b>Non-Cash Disbursements</b>
<b>U.S. DEPARTMENT OF AGRICULTURE</b>				
<i>(Passed through Ohio Department of Education:</i>				
Nutrition Cluster:				
Food Distribution Program	N/A	10.550		\$29,973
National School Breakfast Program	05-PU	10.553	\$66,596	
National School Lunch Program	04-PU	10.555	106,311	
Total Nutrition Cluster			<u>172,907</u>	<u>29,973</u>
<b>Total U.S. Department of Agriculture</b>			172,907	29,973
<b>U.S. DEPARTMENT OF HOUSING &amp; URBAN DEVELOPMENT</b>				
<i>(Passed through Ohio Department of Development)</i>				
Community Development Block Grant	B-F-03-051-1	14.228	26,719	
	B-F-02-051-1		197,156	
	B-X-02-051-1		4,035	
	B-C-03-051-1		143,361	
Total Community Development Block Grant			<u>371,271</u>	
HOME	B-C--03-051-2	14.239	104,056	
<b>Total U.S. Department of Housing &amp; Urban Development</b>			475,327	
<b>U.S. DEPARTMENT OF JUSTICE</b>				
<i>(Passed through Ohio Office of Criminal Justice Services)</i>				
Juvenile Accountability Incentive Block Grant	2003-JB-017-A015	16.523	19,680	
	2002-JB-013-A015		1,377	
Total Juvenile Accountability Incentive Block Grant			<u>21,057</u>	
Crime Victim Assistance (VOCA)	VAGENE120/614/546	16.575	1,200	
	2004VAGENE120		39,195	
	2004VAGENE614		7,577	
	2004VAGENE546T		13,382	
	2005VAGENE120		11,433	
	2005VAGENE614		2,148	
	2005VAGENE546T		4,068	
Total Crime Victim Assistance			<u>79,003</u>	
Byrne Formula Grant Program	2000-DG-C03-2173	16.579	811	
Residential Substance Abuse Treatment for State Prisoners	2002-RS-SAT-143	16.593	63,150	
	2003-RS-SAT-143		10,378	
Total Residential Substance Abuse Treatment for State Prisoners			<u>73,528</u>	
Bulletproof Vest Partnership Program	n/a	16.607	2,608	
Public Safety Partnership and Community Policing Grant	1999CMWX2065	16.710	111,731	
<b>Total U.S. Department of Justice</b>			288,738	
<b>U.S. DEPARTMENT OF LABOR</b>				
<i>(Passed through Ohio Department of Job &amp; Family Services)</i>				
Reed Act	n/a	17.225	1,299	
Workforce Investment Act Cluster:				
WIA - Adult	n/a	17.258	81,554	
WIA - Adult (Administrative)	n/a		(462)	
<i>(Passed through Workforce Investment Act, Area 7)</i>				
WIA - Adult	n/a	17.258	47,151	
WIA - Adult (Administrative)	n/a		250	
Total WIA - Adult			<u>128,493</u>	
<i>(Passed through Ohio Department of Job &amp; Family Services)</i>				
WIA - Youth	n/a	17.259	24,219	
WIA - Youth (Administrative)	n/a		(137)	
<i>(Passed through Workforce Investment Act, Area 7)</i>				
WIA - Youth	n/a	17.259	56,536	
WIA - Youth (Administrative)	n/a		300	
Total WIA - Youth			<u>80,918</u>	
<i>(Passed through Ohio Department of Job &amp; Family Services)</i>				
WIA - Dislocated Worker	n/a	17.260	68,684	
WIA - Dislocated Worker (Administrative)	n/a		(389)	
<i>(Passed through Workforce Investment Act, Area 7)</i>				
WIA - Dislocated Worker	n/a	17.260	33,905	
WIA - Dislocated Worker (Administrative)	n/a		180	
Total WIA - Dislocated Worker			<u>102,380</u>	
Total Workforce Investment Cluster			311,791	
<b>Total U.S. Department of Labor</b>			313,090	

**FINANCIAL CONDITION  
MIAMI COUNTY**

**SCHEDULE OF FEDERAL AWARD EXPENDITURES  
FOR YEAR ENDED DECEMBER 31, 2004  
(Continued)**

Federal Grantor / Pass Through Grantor Program Title	Pass Through Entity Number	CFDA Number	Disbursements	Non-Cash Disbursements
<b>U.S. DEPARTMENT OF TRANSPORTATION</b>				
<i>(Passed through Ohio Department of Transportation)</i>				
Federal Transit Formula Grant	OH-90-X486	20.507	194,986	
Highway Planning and Construction	n/a	20.205	32,120	
<b>Total U.S. Department of Transportation</b>			227,106	
<b>GENERAL SERVICE ADMINISTRATION</b>				
<i>(Passed through Ohio Secretary of State)</i>				
Election Reform	04-SOS-HAVA-55	39.011	15,440	
<b>U.S. DEPARTMENT OF EDUCATION</b>				
<i>(Passed through Ohio Department of Education)</i>				
Special Education Cluster				
Special Education Grants to States	071142-6B-SF04	84.027	18,284	
	071142-6B-SF05		2,830	
Total Special Education Grants to States			21,114	
Special Education Preschool Grant	071142-PGS1-2004	84.173	9,896	
	071142-PGS1-2005		1,510	
Total Special Education Preschool Grant			11,406	
Total Special Education Cluster			32,520	
State Grants for Innovative Programs	071142-C2-S1-2004	84.298	220	
	071142-C2-S1-2005		10	
Total State Grants for Innovative Programs			230	
<i>(Passed through Ohio Department of Health)</i>				
Special Education Grants for Families and Infants with Disabilities	55-1-002-EG-04	84.181	13,908	
	55-1-002-EG-04		14,007	
Total Special Education Grants for Families and Infants with Disabilities			27,915	
<b>Total U.S. Department of Education</b>			60,665	
<b>U.S. DEPARTMENT OF HUMAN SERVICES</b>				
<i>(Passed through Ohio Department of Job and Family Services)</i>				
Children Welfare	n/a	93.645	8,250	
	n/a		7,366	
ESSA	n/a		15,959	
	n/a		31,120	
Total Children Welfare			62,695	
Child Abuse and Neglect State Grant	n/a	93.669	1,519	
Chaffee Foster Independent Living	n/a	93.674	2,220	
			1,063	
			3,283	
<i>(Passed through Ohio Department of Mental Retardation and Developmental Disabilities)</i>				
Title XX - Social Services Block Grant	n/a	93.667	38,712	
			24,809	
Total Title XX - Social Services Block Grant			63,521	
Medical Assistance (CAFS)	n/a	93.778	71,103	
	n/a		70,985	
	n/a		591,772	
	n/a		235,965	
Medical Assistance (TCM)	n/a		52,525	
	n/a		104,924	
	n/a		54,122	
Medical Assistance (Independent Option)	n/a		45,255	
Medical Assistance (Level One)	n/a		43	
Total Medical Assistance			1,226,694	
<b>Total U.S. Department of Human Services</b>			1,357,712	

**FINANCIAL CONDITION  
MIAMI COUNTY**

**SCHEDULE OF FEDERAL AWARD EXPENDITURES  
FOR YEAR ENDED DECEMBER 31, 2004  
(Continued)**

<b>Federal Grantor / Pass Through Grantor Program Title</b>	<b>Pass Through Entity Number</b>	<b>CFDA Number</b>	<b>Disbursements</b>	<b>Non-Cash Disbursements</b>
<b>CORPORATION FOR NATIONAL &amp; COMMUNITY SERVICES</b>				
<i>(Passed through Ohio Department of Youth Services)</i>				
AmeriCorps	YCP-002-03	94.006	1,393	
<b>DEPARTMENT OF HOMELAND SECURITY</b>				
<i>(Passed through Ohio Emergency Management Agency)</i>				
State Domestic Preparedness Equipment Support Program	2002-TE-CX-0049	97.004	9,050	
	2002-TX-CX-0106		123,326	
	2003-MUP-30015		266,118	
	2003-TE-TX-0199		135,235	
	2001-TE-CX-0016		1,210	
Total State Domestic Preparedness Equipment Support Program			<u>534,939</u>	
Emergency Management Preparedness Grant	EMC-2004-GR-7007	97.042	34,413	
Predisaster Mitigation	EMC-2003-GR-7043	97.047	3,436	
State & Local Hazards Emergency Operation Planning	109-497OR-00	97.051	2,700	
ODP Citizens Corps Program Grant	2004-GC-T4-0025	97.053	2,050	
FEMA Community Emergency Response Team Grant	EMC-2003-GR-7066	97.054	2,696	
<b>Total Department of Homeland Security</b>			<u>580,234</u>	
<b>Total Federal Assistance</b>			<u><b>\$3,492,612</b></u>	<u><b>\$29,973</b></u>

*The accompanying notes to this schedule are an integral part of this schedule.*

**MIAMI COUNTY FINANCIAL CONDITION  
MIAMI COUNTY  
DECEMBER 31, 2004**

**NOTES TO SCHEDULE OF FEDERAL AWARDS EXPENDITURES**

**NOTE A – SIGNIFICANT ACCOUNTING POLICIES**

The accompanying Schedule of Federal Awards Expenditures (the Schedule) summarizes activity of the County's federal award program. The schedule has been prepared on the cash basis of accounting.

**NOTE B – FOOD DISTRIBUTION**

Non-monetary assistance, such as food received from the U.S. Department of Agriculture, is reported in the Schedule at the fair market value of the commodities received and consumed. Cash receipts from the U.S. Department of Agriculture are commingled with State grants. It is assumed federal monies are expended first. At December 31, 2004, the County had no significant food commodities in inventory.

**NOTE C – MATCHING REQUIREMENTS**

Certain Federal programs require that the County contribute non-Federal funds (matching funds) to support the Federally-funded program. The County has complied with the matching requirements. The expenditure of non-Federal matching funds is not included on the Schedule.

**NOTE D – COMMINGLING OF FEDERAL MONIES**

Several federal grant program monies were commingled with state and / or local revenues. It is assumed federal monies are expended first.





**Auditor of State  
Betty Montgomery**

**INDEPENDENT ACCOUNTANTS' REPORT ON INTERNAL CONTROL OVER  
FINANCIAL REPORTING AND ON COMPLIANCE AND OTHER MATTERS  
REQUIRED BY *GOVERNMENT AUDITING STANDARDS***

Board of Miami County Commissioners  
Miami County Auditor  
Miami County Treasurer  
Miami County Safety Building  
201 West Main Street  
Troy, Ohio 45373

To the Board of County Commissioners, County Auditor, and County Treasurer:

We have audited the financial statements of the governmental activities, the business-type activities, the discretely presented component unit, each major fund, and the aggregate remaining fund information of Miami County, (the County), as of and for the year ended December 31, 2004, which collectively comprise the County's basic financial statements and have issued our report thereon dated July 27, 2005. We did not audit the financial statements of Riverside Training Industries, Inc., which represents 100 percent of the assets and revenues of the component unit column. Those financial statements were audited by other auditors whose report thereon has been furnished to us and our opinion, in so far as it relates to the amounts included for the discretely presented unit, is based on the report of the other auditors. We conducted our audit in accordance with auditing standards generally accepted in the United States of America and the standards applicable to financial audits contained in the Comptroller General of the United States' *Government Auditing Standards*.

**Internal Control Over Financial Reporting**

In planning and performing our audit, we considered the County's internal control over financial reporting to determine our auditing procedures in order to express our opinions on the financial statements and not to opine on the internal control over financial reporting. Our consideration of the internal control would not necessarily disclose all matters in the internal control over financial reporting that might be material weaknesses. A material weakness is a reportable condition in which the design or operation of one or more of the internal control components does not reduce to a relatively low level the risk that misstatements caused by error or fraud in amounts material to the financial statements we audited may occur and not be timely detected by employees when performing their assigned functions. We noted no matters involving the internal control over financial reporting and its operation that we consider material weaknesses. In a separate letter to the County's management dated July 27, 2005, we reported other matters involving the internal control over financial reporting that we did not deem to be reportable conditions.

### Compliance and Other Matters

As part of reasonably assuring whether the County's financial statements are free of material misstatement, we tested its compliance with certain provisions of laws, regulations, contracts, and grant agreements, noncompliance with which could directly and materially affect the determination of financial statement amounts. However, providing an opinion on compliance with those provisions was not an objective of our audit and, accordingly, we do not express an opinion. The results of our tests disclosed no instances of noncompliance or other matters that we must report under *Government Auditing Standards*. In a separate letter to the County's management dated July 27, 2005, we reported other matters related to noncompliance we deemed immaterial.

We intend this report solely for the information and use of the audit committee, management, Board of County Commissioners, federal awarding agencies, and pass-through entities. It is not intended for anyone other than these specified parties.

A handwritten signature in black ink that reads "Betty Montgomery". The signature is written in a cursive, flowing style.

**Betty Montgomery**  
Auditor of State

July 27, 2005



## **Auditor of State Betty Montgomery**

### **INDEPENDENT ACCOUNTANTS' REPORT ON COMPLIANCE WITH REQUIREMENTS APPLICABLE TO EACH MAJOR FEDERAL PROGRAM AND ON INTERNAL CONTROL OVER COMPLIANCE IN ACCORDANCE WITH OMB CIRCULAR A-133**

Board of Miami County Board of Commissioners  
Miami County Auditor  
Miami County Treasurer  
Miami County Safety Building  
201 West Main Street  
Troy, Ohio 45373

To the Board of County Commissioners, County Auditor, and County Treasurer

#### **Compliance**

We have audited the compliance of Miami County, (the County), with the types of compliance requirements described in the U.S. Office of Management and Budget (OMB) Circular A-133, Compliance Supplement that apply to each of its major federal programs for the year ended December 31, 2004. The summary of auditor's results section of the accompanying schedule of findings and questioned costs identifies the County's major federal programs. The County's management is responsible for complying with the requirements of laws, regulations, contracts, and grants applicable to each major federal program. Our responsibility is to express an opinion on the County's compliance based on our audit.

We conducted our audit of compliance in accordance with auditing standards generally accepted in the United States of America; the standards applicable to financial audits contained in *Government Auditing Standards* issued by the Comptroller General of the United States; and OMB Circular A-133, *Audits of States, Local Governments, and Non-Profit Organizations*. Those standards and OMB Circular A-133 require that we plan and perform the audit to reasonably assure whether noncompliance occurred with the types of compliance requirements referred to above that could directly and materially affect a major federal program. An audit includes examining, on a test basis, evidence about the County's compliance with those requirements and performing other procedures we considered necessary in the circumstances. We believe our audit provides a reasonable basis for our opinion. Our audit does not provide a legal determination on the County's compliance with those requirements.

In our opinion, the County complied, in all material respects, with the requirements referred to above that apply to each of its major federal programs for the year ended December 31, 2004. However, the results of our auditing procedures disclosed instances of noncompliance with those requirements that OMB Circular A-133 requires us to report, which are described in the accompanying schedule of findings and questioned costs as items 2004-001 and 2004-002. In a separate letter to the County's management dated July 27, 2005, we reported other matters related to federal noncompliance not requiring inclusion in this report.

### **Internal Control Over Compliance**

The County's management is responsible for establishing and maintaining effective internal control over compliance with requirements of laws, regulations, contracts, and grants applicable to federal programs. In planning and performing our audit, we considered the County's internal control over compliance with requirements that could directly and materially affect a major federal program to determine our auditing procedures for the purpose of expressing our opinion on compliance and to test and report on internal control over compliance in accordance with OMB Circular A-133.

Our consideration of the internal control over compliance would not necessarily disclose all matters in the internal control that might be material weaknesses. A material weakness is a reportable condition in which the design or operation of one or more of the internal control components does not reduce to a relatively low level the risk that noncompliance with applicable requirements of laws, regulations, contracts and grants caused by error or fraud that would be material in relation to a major federal program being audited may occur and not be timely detected by employees when performing their assigned functions. We noted no matters involving the internal control over compliance and its operation that we consider to be material weaknesses. However, we noted other matters involving the internal control over federal compliance not requiring inclusion in this report that we reported to the County's management in a separate letter dated July 27, 2005.

### **Federal Awards Expenditures Schedule**

We have audited the governmental activities, business type activities, the discretely presented component unit, each major fund and the aggregate remaining fund information of Miami County as of and for the year ended December 31, 2004 and have issued our report thereon dated July 27, 2005. We did not audit the financial statements of Riverside Training Industries, Inc. (discretely presented component unit). Those financial statements were audited by other auditors. Our audit was performed to form opinions on the financial statements that collectively comprise the County's basic financial statements. The accompanying federal awards expenditures schedule provides additional information as required by OMB Circular A-133 and is not a required part of the basic financial statements. We subjected this information to the auditing procedures applied in the audit of the basic financial statements. In our opinion, this information is fairly stated, in all material respects, in relation to the basic financial statements taken as a whole.

We intend this report solely for the information and use of the audit committee, management, Board of County Commissioners, federal awarding agencies, and pass-through entities. It is not intended for anyone other than these specified parties.



**Betty Montgomery**  
Auditor of State

July 27, 2005

**MIAMI COUNTY FINANCIAL CONDITION  
MIAMI COUNTY**

**SCHEDULE OF FINDINGS AND QUESTIONED COSTS  
OMB CIRCULAR A -133 § .505  
DECEMBER 31, 2004**

**1. SUMMARY OF AUDITOR'S RESULTS**

<b>(d)(1)(i)</b>	<b>Type of Financial Statement Opinion</b>	Unqualified
<b>(d)(1)(ii)</b>	<b>Were there any material control weakness conditions reported at the financial statement level (GAGAS)?</b>	No
<b>(d)(1)(ii)</b>	<b>Were there any other reportable control weakness conditions reported at the financial statement level (GAGAS)?</b>	No
<b>(d)(1)(iii)</b>	<b>Was there any reported material noncompliance at the financial statement level (GAGAS)?</b>	No
<b>(d)(1)(iv)</b>	<b>Were there any material internal control weakness conditions reported for major federal programs?</b>	No
<b>(d)(1)(iv)</b>	<b>Were there any other reportable internal control weakness conditions reported for major federal programs?</b>	<b>No</b>
<b>(d)(1)(v)</b>	<b>Type of Major Programs' Compliance Opinion</b>	Unqualified
<b>(d)(1)(vi)</b>	<b>Are there any reportable findings under § .510?</b>	Yes
<b>(d)(1)(vii)</b>	<b>Major Programs (list):</b>	Community Development Block Grant CDFA #14.228 State Domestic Preparedness Equipment Support Program CFDA # 97.004
<b>(d)(1)(viii)</b>	<b>Dollar Threshold: Type A/B Programs</b>	Type A: > \$ 300,000 Type B: all others
<b>(d)(1)(ix)</b>	<b>Low Risk Auditee?</b>	Yes

**2. FINDINGS RELATED TO THE FINANCIAL STATEMENTS  
 REQUIRED TO BE REPORTED IN ACCORDANCE WITH GAGAS**

None

**3. FINDINGS AND QUESTIONED COSTS FOR FEDERAL AWARDS**

<b>Finding Number</b>	2004-001
<b>CFDA Title and Number</b>	97.004 – State Domestic Preparedness Equipment Support Program
<b>Federal Award Number / Year</b>	All federal program award numbers
<b>Federal Agency</b>	Department of Homeland Security
<b>Pass-Through Agency</b>	Ohio Emergency Management Agency

**28 CFR 66.32** requires in part that procedures for managing equipment (including replacement equipment), whether acquired in whole or in part with grant funds from the U.S. Department of Justice State Domestic Preparedness Program, until disposition takes place will, as a minimum, meet the following requirements:

- Property records must be maintained that include a description of the property, a serial number or other identification number, the source of property, who holds title, the acquisition date, and cost of the property, percentage of Federal participation in the cost of the property, the location, use and condition of the property, and any ultimate disposition data including the date of disposal and sale price of the property.
- A physical inventory of the property must be taken and the results reconciled with the property records at least once every two years.
- A control system must be developed to ensure adequate safeguards to prevent loss, damage, or theft of the property. Any loss, damage, or theft shall be investigated.
- Adequate maintenance procedures must be developed to keep the property in good condition.

Furthermore, the Ohio Emergency Management Agency (EMA) State Domestic Preparedness Program Guidance Package requires the Miami County EMA to be responsible for tracking the equipment purchased, identifying the Agency of Custody, administrative costs, and providing quarterly update reports. The equipment recipient shall be responsible for maintaining all records and accountability of the inventory.

The Miami County EMA has not established procedures per federal and state guidelines, deficiencies noted were:

- A physical inventory was not maintained nor the equipment tracked utilizing property records that included a proper description, tag or serial number, title to the equipment, cost, percentage of Federal participation, location, use, and condition of the property.
- A physical inventory has not been taken and reconciled to the property records.

**Finding Number 2004-001  
 (Continued)**

- An adequate control system has not been implemented which could result in the loss of equipment, damage to equipment, and/or the return of grant funds utilized to purchase the equipment.
- There is no documentation or assurances provided by the Agencies of Custody that the property transferred has been properly maintained.

The County EMA should develop a control system per these guidelines, document or obtain assurances that the property transferred has been properly maintained, and perform a physical inventory of the property acquired with the State Domestic Preparedness Program funds. Proper documentation should be maintained for state and federal auditors.

<b>Finding Number</b>	2004-002
<b>CFDA Title and Number</b>	97.042 - Emergency Management Preparedness Grant
<b>Federal Award Number / Year</b>	EMC-2004-GR-7007
<b>Federal Agency</b>	Department of Homeland Security
<b>Pass-Through Agency</b>	Ohio Emergency Management Agency

**Federal Questioned Cost**

Circular A-87 C.1.d. and the Grant Agreement between The Ohio Emergency Management Agency and Miami County established guidelines for activities allowed in the Emergency Management Preparedness Grant. Allowable grant expenditures were based upon an application and budget submitted by Miami County indicating funds would be utilized for administrative purposes, including planning and training.

During fiscal year 2004, Miami County purchased 6 portable radios for a total of \$16,863 from these funds. Equipment was not an approved item on the approved budget and is therefore a questioned cost for the Emergency Management Preparedness Grant.

**MIAMI COUNTY FINANCIAL CONDITION  
MIAMI COUNTY  
DECEMBER 31, 2004**

**CORRECTIVE ACTION PLAN  
OMB CIRCULAR A -133 § .315 (c)**

Finding Number	Planned Corrective Action	Anticipated Completion Date	Responsible Contact Person
2004-001	The Miami County Emergency Management Agency is currently in the process of conducting an inventory, obtaining all information to be reported on an inventory and obtaining transfer statements from agencies receiving equipment.	July 2005	Ken Artz, Director
2004-002	The County will research the finding, contact the state EMA, and return the funds to the agency after confirming the calculations.	July 2005	Ken Artz, Director



*MIAMI COUNTY, OHIO*

---

*County Seat  
Troy, Ohio*



COMPREHENSIVE ANNUAL FINANCIAL REPORT

FOR THE YEAR ENDED  
DECEMBER 31, 2004



**MIAMI COUNTY, OHIO**

---

COMPREHENSIVE ANNUAL FINANCIAL REPORT

FOR THE YEAR ENDED  
DECEMBER 31, 2004

*Chris A. Peebles  
County Auditor*

*Prepared by the  
Miami County Auditor's Office*

*MIAMI COUNTY, OHIO*

---



201 West Main Street  
Troy, Ohio 45373  
(937) 440-5925  
(937) 440-3530

<http://www.co.miami.oh.us>

TABLE OF CONTENTS

MIAMI COUNTY, OHIO

**I** INTRODUCTORY SECTION

**A** Letter of Transmittal ..... v  
**B** List of Elected Officials ..... xvi  
**C** County Organizational Chart ..... xvii  
**D** Certificate of Achievement for Excellence in Financial Reporting..... xviii

**II** FINANCIAL SECTION

**A** Independent Accountants' Report ..... 1  
**B** Management's Discussion and Analysis ..... 3  
**C** Basic Financial Statements:  
    Government-wide Financial Statements:  
        Statement of Net Assets ..... 13  
        Statement of Activities ..... 14  
    Fund Financial Statements:  
        *Governmental Funds:*  
            Balance Sheet ..... 16  
            Reconciliation of Total Governmental Fund Balances to Net Assets of  
            Governmental Activities ..... 18  
            Statement of Revenues, Expenditures and Changes in Fund Balances ..... 20  
            Reconciliation of the Statement of Revenues, Expenditures and Changes  
            in Fund Balances to the Statement of Activities ..... 22  
            Statement of Revenues, Expenditures and Changes in Fund Balance  
            (Budget and Actual):  
                General Fund ..... 23  
                Motor Vehicle and Gasoline Tax Fund ..... 24  
                Job and Family Services Fund ..... 25  
                Mental Retardation and Developmental Disabilities Board Fund ..... 26  
        *Proprietary Funds:*  
            Statement of Net Assets ..... 28  
            Statement of Revenues, Expenses and Changes in Fund Net Assets ..... 30  
            Statement of Cash Flows ..... 32  
        *Fiduciary Funds:*  
            Statement of Net Assets ..... 36  
            Statement of Changes in Net Assets ..... 37  
Notes to the Basic Financial Statements ..... 38

**MIAMI COUNTY, OHIO**

---

**D Combining and Individual Fund Statements and Schedules:**

Nonmajor Governmental Financial Statements:

Combining Balance Sheet .....	82
Combining Statement of Revenues, Expenditures and Changes in Fund Balances .....	83
Combining Balance Sheet – Nonmajor Special Revenue Funds.....	84
Combining Statement of Revenues, Expenditures and Changes in Fund Balances – Nonmajor Special Revenue Funds.....	90
Combining Balance Sheet – Nonmajor Debt Service Funds.....	96
Combining Statement of Revenues, Expenditures and Changes in Fund Balances – Nonmajor Debt Service Funds.....	97
Combining Balance Sheet – Nonmajor Capital Projects Funds.....	98
Combining Statement of Revenues, Expenditures and Changes in Fund Balances – Nonmajor Capital Projects Funds.....	99
Individual Schedules of Revenues, Expenditures and Changes in Fund Balance (Budget and Actual):	

Major Governmental Funds:

<i>General Fund</i> .....	100
<i>Special Revenue Funds:</i>	
Motor Vehicle and Gasoline Tax Fund.....	110
Job and Family Services Fund .....	111
Mental Retardation and Developmental Disabilities Board Fund .....	112

Nonmajor Governmental Funds:

<i>Special Revenue Funds:</i>	
Child Support Enforcement Agency Fund.....	113
Dog and Kennel Fund.....	114
Shelter/Domestic Violence Fund .....	115
Youth Services Subsidy Fund.....	116
E-911 Emergency Operations Fund.....	117
Public Defender Fund .....	118
Delinquent Tax Collection Fund.....	119
Real Estate Appraisal Fund.....	120
Pre-Trial Services Fund .....	121
County Conservancy Fund.....	122
Community Based Corrections Act Grant Fund .....	123
Super Cleanup Fund.....	124

**MIAMI COUNTY, OHIO**

---

*Special Revenue Funds (Continued):*

Emergency Management Agency Fund.....	125
Enforcement and Education Fund.....	126
Juvenile Detention/Rehabilitation Center Fund.....	127
County Probation Services Fund .....	128
Recycle Grant Fund .....	129
Day Reporting Program Fund.....	130
Urban Mass Transportation Fund .....	131
Community Development Block Grant Fund.....	132
Children's Services Board Fund.....	133
Legal Research Fund .....	134
One-Stop Shop Fund.....	135
Law Enforcement Fund .....	136
County Recorder Equipment Fund .....	137
Court Computerization Fund .....	138
D.A.R.E. Fund .....	139
Dispute Resolution Fund .....	140
COPS More '96 Fund.....	141
Commissary Fund.....	142
Food Services Fund .....	143
Common Pleas Court – Special Projects Fund .....	144
Sheriff's Juvenile Safety Trust Fund .....	145
Municipal Court Restitution Fund .....	146
Children's Services Trust Fund .....	147
D.A.R.E. Trust Fund.....	148

*Debt Service Funds:*

General Obligation Debt Fund.....	149
Special Assessment Debt Fund.....	150

*Capital Projects Funds:*

Sewer System Improvement Fund.....	151
Permanent Improvement Fund.....	152
Health Care Capital Improvement Fund .....	153
Emergency 911 Facility Construction Fund .....	154
Ditch Construction Fund.....	155

**MIAMI COUNTY, OHIO**

---

Fiduciary Funds – Agency Fund:  
    Combining Statement of Changes in Assets and Liabilities ..... 158

Capital Assets Used in the Operation of Governmental Funds:  
    Schedule by Source..... 165  
    Schedule by Function and Activity..... 166  
    Schedule of Changes by Function and Activity..... 168

**III**

**STATISTICAL SECTION**

General Government Expenditures by Function - Last Ten Years..... S 2  
General Government Revenues By Source - Last Ten Years..... S 3  
Property Tax Levies and Collections - Last Ten Years ..... S 4  
Assessed Valuations and Estimated True Values of Taxable Property -  
Last Ten Years..... S 5  
Property Tax Rates - All Direct and Overlapping Governments - Last Ten Years ..... S 6  
Computation of Legal Debt Margin ..... S 8  
Ratio of Net General Obligation Bonded Debt to Assessed Value and Net  
General Obligation Bonded Debt Per Capita - Last Ten Years ..... S 9  
Ratio of Annual Debt Service Expenditures for General Obligation  
Bonded Debt to Total General Government Expenditures - Last Ten Years ..... S 10  
Computation of All Direct and Overlapping General Obligation Debt..... S 11  
Demographic Statistics - Last Ten Years ..... S 12  
Property Value and Construction Permits - Last Ten Years..... S 13  
Principal Taxpayers (Property Tax) ..... S 14  
Principal Employers ..... S 15  
Salaries of Principal Officials..... S 16  
Surety Bond Coverage - Various Officials..... S 17  
Miscellaneous Statistics..... S 18



## *INTRODUCTORY SECTION*

---

---



**CHRIS A. PEEPLES**  
**Miami County Auditor**



Miami County Safety Building  
201 W. Main Street  
Troy, Ohio 45373  
(937) 440-5934

---

July 27, 2005

To The Citizens of Miami County,  
and the Board of County Commissioners:

The Comprehensive Annual Financial Report (CAFR) for Miami County, Ohio (the "County") for the fiscal year ended December 31, 2004 is hereby presented to its citizens. The report has been prepared in accordance with generally accepted accounting principles established by statements of the Governmental Accounting Standards Board (GASB), other authoritative pronouncements and guidelines recommended by the Government Finance Officers Association of the United States and Canada (GFOA).

**Introduction**

While there is no legal requirement for the preparation of this report, it represents a commitment by Miami County to conform to nationally recognized standards of excellence in financial reporting. Responsibility for both the accuracy of the presented data, and the completeness and fairness of the presentation, including all disclosures, rests with the County Auditor's Office. To the best of our knowledge and belief, the enclosed data, as presented, is accurate in all material respects, is presented in a manner designed to fairly set forth the financial position and results of operations of the County, and presents all disclosures necessary to enable the reader to gain an understanding of the County's financial activity.

Generally Accepted Accounting Principles require that management provide a narrative introduction, overview and analysis to accompany the basic financial statements in the form of Management's Discussion and Analysis (MD&A). This letter of transmittal is designed to complement MD&A and should be read in conjunction with it. Miami County's MD&A can be found immediately following the independent accountants' report.

**The Report:**

This Comprehensive Annual Financial Report (CAFR) is designed to assist and guide the reader in understanding its contents. The report is comprised of the following three major sections:

1. The Introductory Section includes this letter of transmittal which presents the County's organization, operational structure and accomplishments; an organizational chart, a list of elected officials; and the Certificate of Achievement for Excellence in Financial Reporting.

## **MIAMI COUNTY, OHIO**

---

### ***Letter of Transmittal***

***For the Year Ended December 31, 2004***

---

2. *The Financial Section* contains the Independent Accountants' Report, Management's Discussion and Analysis, the Basic Financial Statements and Notes that provide an overview of the County's financial position and operating results, the Combining Statements for nonmajor funds and other schedules that provide detailed information relative to the Basic Financial Statements.
3. *The Statistical Section* presents social, economic, and historical data in a multi-year format which can be used to identify financial trends and data relative to the fiscal capacity of the County.

### **The Reporting Entity:**

The accompanying basic financial statements comply with the provisions of Governmental Accounting Standards Board (GASB) Statement No. 14, *The Financial Reporting Entity*, in that the financial statements include all the organizations, activities, functions and component units for which the County (the reporting entity) is financially accountable. Financial accountability is defined as the appointment of a voting majority of the component unit's board, and either (1) the County's ability to impose its will over the component unit, or (2) the possibility that the component unit will provide financial benefit to, or impose a financial burden on, the County. Therefore, the reporting entity of the County includes the following services: human and social services, health and community assistance related services, law enforcement, civil and criminal justice system services, road and bridge maintenance, and other general and administrative support services. The County also operates a water distribution system, a wastewater collection and treatment system and a solid waste transfer station.

In addition to general government activities, the County is financially accountable for the following legally separate entities: the Miami County Board of Mental Retardation/Developmental Disabilities (MRDD), Miami County Children Services Board and the Miami County Public Defender Commission, therefore, these activities are included in the reporting entity.

Riverside Training Industries (RTI) is an adult workshop operated for clients throughout Miami County. Miami County has an annual master operating agreement with RTI to subsidize a portion of the operations. RTI contracts with various companies and individuals including the County to provide janitorial services, assembly work, packaging, clerical, and other activities which are performed by the workshop participants. Separate financial statements for RTI may be obtained from RTI's administrative offices at 110 Foss Way, Troy, Ohio 45373.

Miami County participates in a jointly governed organization with Shelby and Darke counties in the operation of the Tri-County Board of Alcohol, Drug and Mental Health Services (Tri-County Board). Miami County is the fiscal agent for the Board and therefore, the financial activity of the Board is included within the County's financial statements.

The County's officials are also responsible for appointing the members of the boards of other organizations, but the County's accountability for these organizations does not extend beyond making the appointments. The Board of County Commissioners appoints a voting majority of the Troy-Miami County Public Library Board and the Miami County Visitors and Convention Bureau. In addition, the Courts and Board of County Commissioners appoint a majority of the board of the Miami Metropolitan Housing Authority, but the County is not financially accountable for these organizations.

## **MIAMI COUNTY, OHIO**

---

### ***Letter of Transmittal For the Year Ended December 31, 2004***

---

Other organizations share some degree of name similarity with the County; however, they constitute separate and distinct entities, not only from the County, but also from each other. The County is not financially accountable for these entities. Due to their independent nature, none of these organizations' financial statements are included in this report. Separate financial statements for these organizations may be obtained by contacting their respective administrative offices. These organizations are as follows:

- Miami County Board of Education
- Miami County Law Library
- Miami County Agricultural Society
- Miami County Community Action Council
- Miami County Residential Living, Inc.
- Miami Valley Regional Planning Commission
- Miami County Humane Society, Inc.
- Miami County Private Industry Council

A thorough presentation of the County's reporting entity is contained in Note 1 of the basic financial statements.

### **County Organization and Services:**

Miami County was established by an act of the State Legislature, April 1, 1807. The Miami River, which flows entirely through the County from north to south, derived its name from the Indian word meaning "Mother" and is the namesake for Miami County.

Miami County is located in the west central part of the state, approximately 70 miles north of Cincinnati and 70 miles west of Columbus. Its 429.68 square mile area serves a residential population estimated at 98,868 (2000 U.S. Bureau of Census) and is classified as the 27th largest populated county in the state. The County includes 12 townships, 9 villages and 3 cities, with the City of Troy serving as the county seat. The County has only those powers conferred upon it by Ohio statutes. A three member Board of County Commissioners is elected at large in even numbered years for overlapping four year terms. The Board of County Commissioners serves as the taxing authority, the contracting body and the chief administrator of public services for the County. The Board of County Commissioners prepares and adopts the annual operating budget and makes the annual appropriation measure for expenditures of all County funds. In addition to the Board of County Commissioners, the offices of the County Auditor and County Treasurer are included in the category of general government and are of particular importance to the financial affairs of the County.

The County Auditor is elected to a four year term and serves as the chief fiscal officer for the County and the tax assessor for all political subdivisions within the County. According to state law, a complete reappraisal must be conducted every six years as well as a triennial update every third year between reappraisals. Upon collection by the County Treasurer, the County Auditor is responsible for distributing certain taxes to various political subdivisions including municipalities, villages, townships, school and library districts, special districts and County agencies. As chief fiscal officer, the County Auditor must certify that funds for all contracts and obligations of the County have been lawfully appropriated and are available or in the process of collection before the contract or obligation is binding upon the County. In addition, the Auditor is also the central disbursing agent, who by the issuance of County warrants distributes funds to creditors in payment of liabilities incurred by the County. The Auditor is also responsible for the County payroll and has other statutory accounting responsibilities. He is, by state law, secretary of the County Board of Revision and the County Budget Commission and the administrator and supervisor of the County Data Processing Board.

**MIAMI COUNTY, OHIO**

---

***Letter of Transmittal  
For the Year Ended December 31, 2004***

---

The County Treasurer is also elected to a four year term and is the custodian of all County funds. The Treasurer is responsible for collecting all tax monies, applying payments to the appropriate tax accounts and investing all available idle County funds as specified by Ohio law. The Treasurer is the distributing agent for expenditures authorized by the Board of County Commissioners upon the Auditor's warrant. The Treasurer must make daily reports showing receipts, payments and balances to the County Auditor. The Treasurer is a member of the County Board of Revision and the County Budget Commission. The Budget Commission plays an important part in the financial administration of the County government, as well as, all political subdivisions throughout the County.

The other elected officials serving four year terms are the Prosecuting Attorney who serves as the third and final member of the County Budget Commission, the Clerk of Courts, the Recorder, the Sheriff, the Engineer and the Coroner. Three Common Pleas Court Judges and two Municipal Court Judges are elected to six year terms.

**Economic Outlook**

Miami County is located just north of the intersection of two of America's most vital interstate highways, Interstates I-70 and I-75, known as the "Crossroads of America." Interstate I-75 bisects the County from north to south and is a major factor in the continued success of the County's economic development. Miami County is located at the center of the eighth largest 90 minute surface travel market area and the single largest 90 minute air travel market area in North America.

Miami County is in the Dayton-Springfield Metropolitan Statistical Area (MSA), which is the fourth largest MSA in the State of Ohio. Miami County's population comprises approximately ten percent (10%) of the total population of the MSA.

The 2000 Census sets the population of Miami County at 98,868. Based upon the 2000 Census figure, there has been approximately a 6.1% increase in population over the period 1990 to 2000. During the same time period, the Dayton-Springfield MSA showed an estimated .2% decrease in population.

The average 2004 unemployment rate for Miami County increased from 5.3% (2003) to 5.7% (2004). Compared with a 6.1% rate for the State of Ohio and the 6.0% for the nation, Miami County's 5.7% unemployment rate is indicative of the diversity of the County's agricultural, commercial and industrial economic base. Historically, Miami County has experienced a lower unemployment rate than that of the state or the nation.

The diversity of employers is evident when one views a sampling of the businesses that have chosen to locate in Miami County:

<u>Company</u>	<u>Industry</u>
A.O. Smith	Electric motors
American Honda Motor	Automotive parts distribution
Goodrich Corporation	Aircraft wheels and brakes
Evenflo Company Inc.	Juvenile furniture
F & P America Manufacturing Inc.	Automotive parts manufacturing

## **MIAMI COUNTY, OHIO**

---

### ***Letter of Transmittal For the Year Ended December 31, 2004***

---

<u>Company</u>	<u>Industry</u>
French Oil Mill Machinery Co.	Vegetable oil extraction machinery
Charter Corp.	Aircraft propellers
Hartzell Industries	Air movement equipment and wood products
ITW/Hobart Corporation	Commercial food and scale systems
IVEX Corporation	Paper converting
Kerry Ingredients Inc.	Specialty dairy products
MT Picture Display Corp.	Cathode ray (electron) tubes
Systemax Manufacturing	Computers
Orr Felt	Paper and felts
Spinnaker Coatings, LLC	Adhesive coated papers
Upper Valley Medical Center	Health Care

The Miami County Planning and Zoning Department's Comprehensive Land Development Plan notes that the local economy is reliant on the manufacturing and agricultural sectors while retail and service sectors continue to make sizable gains, a trend that is expected to continue.

The County's overall land use goal was summarized as follows:

"It shall be the goal of Miami County to achieve a high-quality living environment through a wise distribution of compatible land use patterns and to reflect the integrity of the natural environment while accommodating development within communities that meet the social and economic needs of Miami County residents."

In preparation for the future, the private and public sector are working to assure the availability of building sites for all types of business activities.

In the south central portion of the County, a public-private partnership between the City of Tipp City and a private developer (Logan-Berry Properties) is facilitating the installation of necessary infrastructure for a new, 90 acre commercial development. The property was subdivided into six commercial lots and four industrial lots ranging from 3.4 to 33.2 acres. Also in the City of Tipp City, the Northgate Commerce Center, located south of State Route 571, has 50 acres in phase one and 80 acres in phase two available for industrial development. During 2004, Tipp City approved an incentive package for Transfreight LLC., which enticed them to locate within the commerce center. Transfreight invested \$5.8 million in a new 120,000 square foot building. Operations started in December 2004 and currently employs 70 people.

In the City of Troy, the Town Park Drive development broke ground in 2003 and will be home to a commercial mix of offices and retail. Each of these properties are conveniently located along Interstate 75, which will help with the marketing of these important commercial developments.

American Honda Motor Co., Inc. will construct a new domestic parts distribution hub and procurement operations support office in Troy. The new 500,000 square foot center will be located along I-75, south of their existing Honda facility, at a cost of \$89 million. Construction is expected to begin in the spring of 2006 and be completed by the fall of 2007. The expansion of warehouse operations will add 110 new full-time positions.

Hartzell Propeller will construct a 17,022 square foot airplane hanger storage building in Piqua at a cost of \$490,808.

## **MIAMI COUNTY, OHIO**

---

*Letter of Transmittal  
For the Year Ended December 31, 2004*

---

### **Major Initiatives**

#### **Present:**

##### **Miami County Sanitary Engineer**

Infrastructure improvements continued in the Merrimont and Cedar Ridge subdivisions with the extension of water and sewer lines throughout the subdivisions to replace wells and failing septic systems. Design work and construction of water and sewer lines, originally began in 2000, and work continues into 2005 with additional water and sewer line construction. Reimbursement for the residents share of the cost of the projects will be derived from assessments to the property owners and from tap fees as connections are made to the new lines. The cost of construction is approximately \$2.2 million.

##### **Miami County Transit System**

The Miami County Commissioners implemented the Miami County Transit System in July of 2003. The system was established to provide a quality, efficient, safe and reliable transportation program to the citizens of the County. The program has flexible daily service schedules, inexpensive fares and assists individuals, groups and community service organizations with their transportation needs. The County is transporting nearly 5,000 riders per month utilizing 19 vehicles. The County has successfully obtained a number of Federal, State and local subsidy funding sources which will reduce the overall cost of the system to the Miami County taxpayers.

#### **Future:**

##### **The Miami County Geographic Information System (MCGIS)**

The MCGIS is a multi-layered computerized mapping system. Phases I, II and III of the project have been completed. Cadastral maps (also referred to by a variety of names including assessment, appraisal, property, real estate and tax maps) show the boundaries of the 48,415 parcels of land in Miami County. In addition, the maps display the size and location of each parcel relative to other properties, streams, roads and other major physical and cultural features. The MCGIS will be used in conjunction with the Auditor's existing computer assisted mass appraisal system (CAMA) to improve the quality and accuracy of the property tax assessments which are related to the market value appraisals and the Current Agricultural Use Valuation program.

In early 2002, the County entered into a contract for the countywide Digital Orthophotography and LIDAR (light detection and ranging) contour project. The project has re-established and refined horizontal and vertical ground control on 120 existing monuments in the project area. The final product provides a current Orthophotography of Miami County cities and villages along with 2' contour elevation maps. The MCGIS will also be a major tool for Miami County's 2007 reappraisal. The Digital Orthophotography will give the appraisers a better view of the properties and overlaid cadastral maps will show the property boundaries on the orthophotos.

The next step in the development of the MCGIS is implementation, which has been accomplished by integrating the MCGIS with the current Auditor's CAMA and tax accounting systems. Contracts for the integration phase were signed in the fall of 2003, with implementation anticipated in 2005. Once implementation is completed, the County will make scheduled information available to the public via the Internet.



**MIAMI COUNTY, OHIO**

---

**Letter of Transmittal  
For the Year Ended December 31, 2004**

---

Bridge

Future major bridge improvement projects include the following:

<u>Project Name</u>	<u>Project Type</u>	<u>Estimated Cost</u>	<u>Estimated Completion Date</u>
Covington-Gettysburg Road Bridge No. 2.30	Bridge Replacement	\$468,000	October 2005
Shawnee Bridge, Piqua	Bridge Replacement	6,200,000	July 2006
Rusk Road Bridge	Bridge Replacement	310,000	October 2006

**Financial Information**

This is the second year the County has prepared financial statements following GASB Statement 34, "Basic Financial Statements – and Management’s Discussion and Analysis – for State and Local Governments."

As part of this new reporting model, management is responsible for preparing Management’s Discussion and Analysis (MD&A) of the County. This discussion appears after the Independent Accountants’ Report in the financial section of this report. MD&A provides an assessment of the County’s finances for 2004.

**Government-wide financial statements** These statements are prepared on an accrual basis of accounting, which is similar to the basis of accounting followed by businesses. The government-wide statements distinguish between those activities of the County that are governmental and those that are considered business-type activities.

**Fund financial statements** These statements present information for individual major funds rather than by fund type. Nonmajor funds are presented in total in one column. Governmental funds use the modified accrual basis of accounting and include a reconciliation to the governmental activities accrual information presented in the government-wide financial statements. Proprietary and fiduciary funds use the accrual basis of accounting.

**Statement of budgetary comparisons** These statements present comparisons of actual information to the legally adopted budget. The budgetary basis as provided by law is based upon accounting for certain transactions on a basis of cash receipts, disbursements and encumbrances.

**Internal Control, Budgetary Control and the Accounting System:**

Development of the County's accounting system included substantial consideration of the adequacy of the internal accounting controls. Internal accounting controls are designed to provide reasonable, but not absolute assurance that:

1. The County's assets are protected against loss and unauthorized use or disposition; and
2. Reliable financial reports for preparing financial statements and providing accountability for assets are maintained.

**MIAMI COUNTY, OHIO**

---

***Letter of Transmittal  
For the Year Ended December 31, 2004***

---

The concept of reasonable assurance states that internal controls should be evaluated applying the following criteria:

1. The expense associated with providing the internal controls should not exceed the benefits likely to be derived from their implementation; and
2. The evaluation of the offsetting costs and benefits involves estimates and judgment by the County administration and members of the Auditor's office.

All internal control evaluations occur within this framework. It is the belief of the administrative and financial management personnel that the County's financial controls adequately safeguard existing assets and provide reasonable assurance of the proper recording of financial transactions.

The Accounting Department of the County Auditor's Office is responsible for the auditing and analysis of all purchase orders and vouchers of the County. Accounting Department personnel review the purchase orders and vouchers to ensure the availability of monies in the proper funds and accounts prior to certification and payment of approved invoices. The County utilizes a fully automated accounting system, as well as an automated system of controls for fixed asset accounting and payroll. These systems, coupled with the review and examination performed by the County Auditor's Office, ensure that the financial information generated is both accurate and reliable.

Budgetary appropriations for the operation of the County's departments are established through the adoption of the annual appropriation resolution by the Board of County Commissioners. All disbursements and transfers of cash between funds require appropriation authority from the County Commissioners. Budgets are controlled at the object level within department, by function and fund. Purchase orders are requested by the department head and encumbered prior to their release to vendors. Those purchase orders which exceed the available appropriations are rejected until additional appropriations are secured. A computerized certification system allows the Auditor's Office to ascertain the status of appropriations prior to authorizing purchases.

Budgetary control is maintained at the object level for each department by function (Public Safety, Health, Human Services, Conservation/Recreation, Public Works, General Government, Debt Service and Capital Outlay) within each fund via legislation approved by the County Commissioners.

The various object levels are:

- |   |                           |   |                        |
|---|---------------------------|---|------------------------|
| * | Personal services         | * | Materials and supplies |
| * | Contractual services      | * | Capital Outlay         |
| * | Travel and Transportation | * | Debt Service           |
| * | Transfers                 |   | Principal Interest     |

Lower levels within each object are accounted for and reported internally. Such lower levels are referred to as line items of expenditure. Estimated amounts must be encumbered prior to final approval of purchase orders or other contracts to vendors. Unencumbered appropriations return (lapse) to the unappropriated balances in the individual funds at the end of each fiscal year which coincides with the calendar year. Appropriations, both original and supplemental, must be authorized by the Board of County Commissioners.

## **MIAMI COUNTY, OHIO**

---

### ***Letter of Transmittal For the Year Ended December 31, 2004***

---

#### **Cash Management:**

Cash management is a vital component of the County's overall financial strategy. The primary objective of the County's investment activity is the preservation of capital and the protection of invested principal. The County pools its cash to simplify cash management. Miami County participates in the State Treasury Asset Reserve of Ohio (STAR Ohio). The statewide investment pool was established in January 1986, for governmental entities in Ohio and is administered by the Treasurer of the State of Ohio. In addition to STAR Ohio, the Treasurer invests in short-term certificates of deposit and U. S. Treasury Notes. Certain agency fund money is deposited and maintained in segregated bank accounts. Investment income is allocated to the General Fund and other qualifying funds, as prescribed by Ohio law. Investment income for all funds of the primary government was \$788,810 for fiscal year 2004.

Public funds are invested to achieve maximum return on the portfolio without assuming unreasonable risk.

#### **Risk Management:**

In its continuing effort to maintain quality insurance coverage at a reasonable cost, the County contracted with County Risk Sharing Authority (CORSA) for the following insurance coverages:

- Property, Inland Marine
- Crime and Fidelity
- General Liability
- Law Enforcement Liability
- Public Officials Liability
- Auto Liability and Physical Damage
- Comprehensive Boiler and Machinery

The County Risk Sharing Authority was established in 1987 by the County Commissioners Association of Ohio to provide comprehensive property and liability coverage for counties in Ohio. The objectives of the program are comprehensive protection, stability, and long-term cost savings. CORSA is governed by a nine member Board of Trustees which are elected by the members of the pool. The County maintains general, automobile, law enforcement and public officials liability coverage in the amount of \$6,000,000 for each occurrence with a \$2,500 deductible. Blanket building and personal property insurance is in the amount of \$106,299,515.

In addition, CORSA provides loss control services designed to identify and report areas of hazard that are often unique to public entities. The CORSA loss control personnel work with County personnel to control losses through loss prevention (lowering the probability of loss) and loss reduction (lowering the severity of the loss).

Workers' compensation coverage is maintained by paying premiums to the State Bureau of Workers Compensation. The premium is based on a rate per \$100 of payroll and is calculated based upon accident history and administrative costs.

## **MIAMI COUNTY, OHIO**

---

### ***Letter of Transmittal For the Year Ended December 31, 2004***

---

The County is self-funded for employee health care benefits. The program is administered by Medical Mutual of Ohio, which provides claim review and processing services. Each County fund is charged for its proportionate share of coverage. The County's liability is limited to a maximum loss of \$100,000 per employee through the purchase of stop loss insurance.

#### **Debt Administration:**

The debt service funds accumulate resources for the payment of principal, interest and associated administrative costs on the County's debt. Resources are derived from transfers.

The County's general obligation bonds are presently rated Aa3 by Moody's Investors Service. The total bonded debt of the County at December 31, 2004, was \$11,940,000 which consisted entirely of the following:

Unvoted general obligation bonds/non-self supported	\$7,050,000
Unvoted general obligation bonds/self supported	\$4,890,000

Under current state statutes, the total voted and unvoted net debt of the County, less the same exempt debt shall never exceed a sum equal to three percent of the first \$100,000,000 of the assessed valuation, plus one and one-half percent of such valuation in excess of \$100,000,000 and not in excess of \$300,000,000, plus two and one-half percent of such valuation in excess of \$300,000,000. At December 31, 2004, the County had an unvoted debt margin of \$14,220,748 and a direct margin of \$44,496,141.

A more thorough presentation of the calculation of these figures is located in the statistical section of this report.

### **Other Information**

#### **Independent Audit:**

Included in this report is an unqualified opinion rendered on the County's operations and financial position as well as its existing assets and liabilities as reported in the combined financial statements for the year ended December 31, 2004, by Auditor of State, Betty Montgomery. In addition to meeting the requirements set forth in state statutes, the audit was also designed to meet the requirements of the Federal Single Audit Act of 1996 and related OMB Circular A-133.

#### **Awards:**

The Government Finance Officers Association of the United States and Canada (GFOA) awarded a Certificate of Achievement for Excellence in Financial Reporting to Miami County, Ohio for its comprehensive annual financial report for the fiscal year ended December 31, 2003. The Certificate of Achievement is a prestigious national award recognizing conformance with the highest standards in state and local government financial reporting. To be awarded a Certificate of Achievement, a governmental unit must prepare an easily readable and efficiently organized Comprehensive Annual Financial Report whose contents satisfy all program standards. The report must satisfy both generally accepted accounting principles (GAAP) and applicable legal requirements respective to the reporting entity.

**MIAMI COUNTY, OHIO**

---

***Letter of Transmittal  
For the Year Ended December 31, 2004***

---

A Certificate of Achievement is valid for a period of one year only. Miami County has received a Certificate of Achievement for the last thirteen consecutive years (fiscal years ended 1991 - 2003). I believe this current report continues to conform to the Certificate of Achievement program requirements, and I am submitting it to GFOA.

The publication of this Comprehensive Annual Financial Report is indicative of the County's commitment to provide significantly enhanced financial information and accountability to its citizens. In addition to the citizens of Miami County, the recipients of this report include city, state and federal officials, schools, libraries, newspapers, investment banking firms, banks and rating agencies. The report is made available to any person or organization requesting it. The extensive effort to prepare and distribute this report is indicative of the County Auditor's goal of full disclosure of the County's finances.

**Acknowledgments:**

The publication of this report is the culmination of many hours of dedicated work in the research, analysis and preparation of the financial statements and the accompanying notes and narratives. Sincere appreciation is extended to the many individuals who have worked diligently and contributed much time and effort in gathering data for this report, particularly Sharon E. Feltner, Accounting Supervisor, for her untiring determination and high professional standards in the preparation of this report.

I would also like to extend recognition to the staff of the Accounting Department, Jody Collins, Angie Cotrell, Ami Fashner, Charlotte North, Alicia Owens, Laura Penny, Vicki Purk and Missy Rougier for their continued daily efforts throughout the year. In addition, I wish to thank the remaining staff of the County Auditor's Office for their contributions to the on-going operation of the office.

Special acknowledgment is extended to the staff of Donald J. Schonhardt and Associates, Inc. for their continued guidance in the preparation of this report.

Finally, I would especially like to thank the members of the Board of County Commissioners, the other elected county officials and all of the department heads whose support is necessary in order for the County to conform to reporting requirements established for governmental entities and to continue to maintain the sound financial position that Miami County has enjoyed over the years.

Respectfully,



Chris A. Peeples  
Miami County Auditor

**MIAMI COUNTY, OHIO**

---

*List of Elected Officials  
For the Year Ended December 31, 2004*

---

<b>NAME</b>	<b>OFFICE</b>	<b>TERM</b>
<b>BOARD OF COUNTY COMMISSIONERS</b>		
D. Ann Baird	President	01/01/95 - 12/31/06
Ron Widener	Commissioner	01/03/01 - 01/02/09
John F. Evans	Commissioner	12/01/03 - 01/01/09
<b>OTHER ELECTED OFFICIALS</b>		
Chris A. Peeples	Auditor	03/01/91 - 03/11/07
Lydia Callison	Treasurer	01/01/91 - 09/06/09
Douglas L. Christian	Engineer	02/05/79 - 01/04/09
Jan A. Mottinger	Clerk of Courts	01/01/77 - 01/04/09
John O'Brien	Recorder	01/02/96 - 01/04/09
Charles A. Cox, Jr.	Sheriff	01/01/89 - 01/04/09
Gary A. Nasal	Prosecutor	01/30/95 - 01/04/09
Judith A. Nickras, M.D.	Coroner	01/04/93 - 01/04/09
<b>COMMON PLEAS COURT</b>		
Honorable Jeffrey M. Welbaum	Administrative Judge	01/01/95 - 01/01/07
Honorable Robert J. Lindeman	Judge	02/01/91 - 02/08/09
Probate Division:		
Honorable Lynnita K. Wagner	Judge	02/09/97 - 02/08/09
<b>COUNTY MUNICIPAL COURT</b>		
Honorable Elizabeth S. Gutmann	Administrative Judge	01/01/00 - 12/31/05
Honorable A. Melvin Kemmer	Judge	03/28/94 - 12/31/09

MIAMI COUNTY, OHIO

County Organizational Chart  
For the Year Ended December 31, 2004

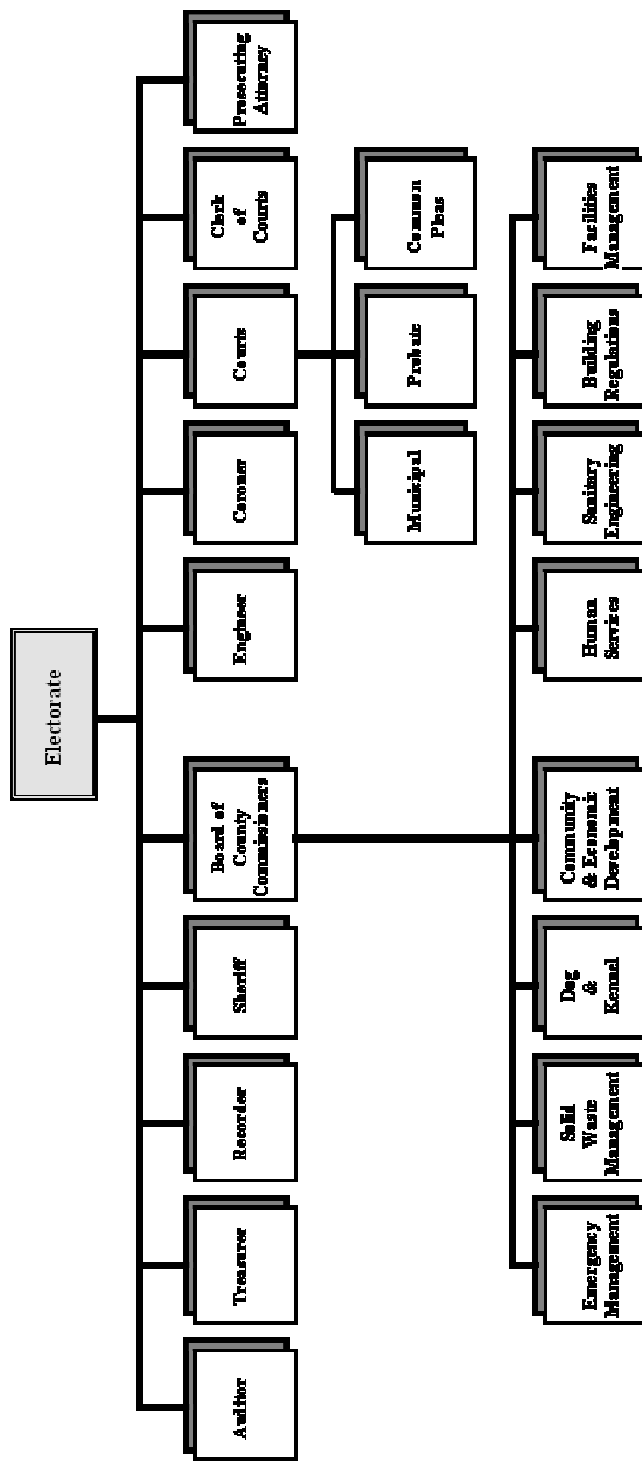

**County Boards and Committees**

- Dea Processing Board
- Board of Revision
- Board of Zoning Appeals
- Children's Services Board
- Human Services Advisory Board
- Board of Elections
- County Budget Commission
- Investment Advisory Committee
- Alcohol, Drug Addiction and Mental Health Services Board
- Mental Retardation/Developmental Disabilities Board
- Water/Wastewater Advisory Committee
- Veterans Services Board
- Microfilming Board
- Planning Commission
- Record Commission
- Rural Zoning Commission
- Solid Waste Advisory Committee
- Park District Board
- Public Defender Commission

*MIAMI COUNTY, OHIO*

---

*Government Finance Officers Association of the United States and Canada  
Certificate of Achievement for Excellence in Financial Reporting*

---

Certificate of  
Achievement  
for Excellence  
in Financial  
Reporting

Presented to

Miami County,  
Ohio

For its Comprehensive Annual  
Financial Report  
for the Fiscal Year Ended  
December 31, 2003

A Certificate of Achievement for Excellence in Financial Reporting is presented by the Government Finance Officers Association of the United States and Canada to government units and public employee retirement systems whose comprehensive annual financial reports (CAFRs) achieve the highest standards in government accounting and financial reporting.



*Nancy L. Zjelke*

President

*Jeffrey R. Emer*

Executive Director



## *FINANCIAL SECTION*

---

---





**Auditor of State  
Betty Montgomery**

**INDEPENDENT ACCOUNTANTS' REPORT**

Board of Miami County Commissioners  
Miami County Auditor  
Miami County Treasurer  
Miami County Safety Building  
201 West Main Street  
Troy, Ohio 45373

We have audited the accompanying financial statements of the governmental activities, the business-type activities, the discretely presented component unit, each major fund, and the aggregate remaining fund information of Miami County, (the County), as of and for the year ended December 31, 2004, which collectively comprise the County's basic financial statements as listed in the table of contents. These financial statements are the responsibility of the County's management. Our responsibility is to express opinions on these financial statements based on our audit. We did not audit the financial statements of Riverside Training Industries, Inc., which represents 100 percent of the assets and revenues of the component unit column. Those financial statements were audited by other auditors whose report thereon has been furnished to us, and our opinion, insofar as it relates to the amounts included for Riverside Training Industries, Inc., is based on the report of the other auditors.

We conducted our audit in accordance with auditing standards generally accepted in the United States of America and the standards applicable to financial audits contained in the Comptroller General of the United States' *Government Auditing Standards*. Those standards require that we plan and perform the audit to reasonably assure whether the financial statements are free of material misstatement. An audit includes examining, on a test basis, evidence supporting the amounts and disclosures in the financial statements. An audit also includes assessing the accounting principles used and significant estimates made by management, as well as evaluating the overall financial statement presentation. We believe our audit provides a reasonable basis for our opinions.

In our opinion, the financial statements referred to above present fairly, in all material respects, the respective financial position of the governmental activities, the business-type activities, the discretely presented component unit, each major fund, and the aggregate remaining fund information of Miami County as of December 31, 2004, and the respective changes in financial position and cash flows, where applicable, thereof and the respective budgetary comparisons for the General Fund, Motor Vehicle and Gasoline Tax Fund, Job and Family Services Fund, and the Mental Retardation and Developmental Disabilities Fund for the year then ended in conformity with accounting principles generally accepted in the United States of America.

One First National Plaza / 130 W. Second St. / Suite 2040 / Dayton, OH 45402  
Telephone: (937) 285-6677 (800) 443-9274 Fax: (937) 285-6688  
[www.auditor.state.oh.us](http://www.auditor.state.oh.us)

In accordance with *Government Auditing Standards*, we have also issued our report dated July 27, 2005, on our consideration of the County's internal control over financial reporting and our tests of its compliance with certain provisions of laws, regulations, contracts and grant agreements and other matters. While we did not opine on the internal control over financial reporting or on compliance, that report describes the scope of our testing of internal control over financial reporting and compliance and the results of that testing. That report is an integral part of an audit performed in accordance with *Government Auditing Standards*. You should read it in conjunction with this report in assessing the results of our audit.

Management's Discussion and Analysis is not a required part of the basic financial statements but is supplementary information accounting principles generally accepted in the United States of America requires. We have applied certain limited procedures, consisting principally of inquiries of management regarding the methods of measuring and presenting the required supplementary information. However, we did not audit the information and express no opinion on it.

We conducted our audit to opine on the financial statements that collectively comprise the County's basic financial statements. The introductory section, combining nonmajor fund statements and schedules and statistical tables provide additional information and are not a required part of the basic financial statements. We subjected the combining nonmajor fund statements and schedules to the auditing procedures applied in the audit of the basic financial statements. In our opinion, this information is fairly stated in all material respects in relation to the basic financial statements taken as a whole. We did not subject the introductory section and statistical tables to the auditing procedures applied in the audit of the basic financial statements and, accordingly, we express no opinion on them.



**Betty Montgomery**  
Auditor of State

July 27, 2005

## MIAMI COUNTY, OHIO

---

*Management's Discussion and Analysis  
For the Year Ended December 31, 2004*

*Unaudited*

---

The discussion and analysis of Miami County's financial performance provides an overall review of the County's financial activities for the fiscal year ended December 31, 2004. The intent of this discussion and analysis is to look at the County's financial performance as a whole; readers should also review the transmittal letter, notes to the basic financial statements and financial statements to enhance their understanding of the County's financial performance.

### FINANCIAL HIGHLIGHTS

**Key financial highlights for 2004 are as follows:**

- ❑ In total, net assets increased \$6.6 million. Net assets of governmental activities increased \$5.8 million, which represents a 4.8% increase from 2003. Net assets of business-type activities increased \$838,019, or 12.9% from 2003.
- ❑ General revenues accounted for \$27.7 million in revenue or 37.3% of all revenues. Program specific revenues in the form of charges for services and grants and contributions accounted for \$46.3 million or 62.3% of total revenues of \$74 million.
- ❑ The County had \$60.9 million in expenses related to governmental activities; only \$39 million of these expenses were offset by program specific charges for services, grants or contributions.
- ❑ Among major funds, the general fund had \$23.3 million in revenues and \$23.6 million in expenditures. The general fund's fund balance decreased \$761,657 to a balance of \$17.1 million.

### OVERVIEW OF THE FINANCIAL STATEMENTS

This annual report consists of three parts – *management's discussion and analysis*, the *basic financial statements*, and an optional section that presents *combining statements* for nonmajor governmental funds. The basic financial statements include two kinds of statements that present different views of the County:

These statements are as follows:

1. *The Government-Wide Financial Statements* – These statements provide both long-term and short-term information about the County's overall financial status.
2. *The Fund Financial Statements* – These statements focus on individual parts of the County, reporting the County's operations in more detail than the government-wide statements.

## **MIAMI COUNTY, OHIO**

---

***Management's Discussion and Analysis  
For the Year Ended December 31, 2004***

***Unaudited***

---

The financial statements also include notes that provide more detailed data and explain some of the information in the financial statements.

### ***Government-wide Statements***

The government-wide statements report information about the County as a whole, including Riverside Training Industries, Inc. the County's discretely presented component unit, using accounting methods similar to those used by private-sector companies. The statement of net assets includes all of the County's assets and liabilities. All of the current year's revenues and expenses are accounted for in the statement of activities regardless of when cash is received or paid.

The two government-wide statements report the County's net assets and how they have changed. Net-assets (the difference between the County's assets and liabilities) is one way to measure the County's financial health or position.

- Over time, increases or decreases in the County's net assets are an indicator of whether its financial health is improving or deteriorating, respectively.
- To assess the overall health of the County you need to consider additional nonfinancial factors such as changes in the County's tax base and the condition of County capital assets.

The government-wide financial statements of the County are divided into two categories:

- *Governmental Activities* – Most of the County's programs and services are reported here including public safety, health, human services, community and economic development and public works.
- *Business-Type Activities* – These services are provided on a charge for goods or services basis to recover all of the expenses of the goods or services provided. All of the County's enterprise activities are reported as business-type activities.

A separately issued audit report containing financial statements is available from Riverside Training Industries, Inc. at 110 Foss Way, Troy, Ohio 45373.

### ***Fund Financial Statements***

The fund financial statements provide more detailed information about the County's most significant funds, not the County as a whole. Funds are accounting devices that the County uses to keep track of specific sources of funding and spending for particular purposes. The County's major governmental funds are the General Fund, the Motor Vehicle and Gasoline Tax Fund, the Job and Family Services Fund and the Mental Retardation and Development Disabilities Board Fund. The County's major enterprise funds are the Water Fund, Sewer Fund, Transfer Station Fund and the Sheriff Police Rotary Fund.

***Governmental Funds*** - Governmental funds are used to account for essentially the same functions reported as governmental activities in the government-wide financial statements. However, unlike the government-wide financial statements, governmental fund financial statements focus on near-term inflows and outflows of expendable resources, as well as on balances of expendable resources available at the end of the year. Such information may be useful in evaluating a government's near-term financing requirements.

**MIAMI COUNTY, OHIO**

---

***Management's Discussion and Analysis  
For the Year Ended December 31, 2004***

***Unaudited***

---

Because the focus of the governmental funds is narrower than that of the government-wide financial statements, it is useful to compare the information presented for governmental funds with similar information presented for governmental activities in the government-wide financial statements. By doing so, readers may better understand the long-term impact of the government's near-term financing decisions. Both the governmental fund balance sheet and the governmental fund statement of revenues, expenditures and changes in fund balances provide a reconciliation to facilitate this comparison between governmental funds and governmental activities.

The County maintains a multitude of individual governmental funds. Information is presented separately in the governmental fund balance sheet and in the governmental statement of revenues, expenditures, and changes in fund balances for the major funds, which were identified earlier. Data from the other governmental funds are combined into a single, aggregated presentation. Individual fund data for each of these nonmajor governmental funds is provided in the form of combining statements elsewhere in this report.

***Proprietary Funds*** - The County maintains two different types of proprietary funds. Enterprise funds are used to report the same functions presented as business-type activities in the government-wide financial statements. The County uses four enterprise funds to account for water, sewer, transfer station and sheriff police rotary operations. All of the County's enterprise funds are presented as major funds.

Internal Service funds are an accounting device used to accumulate and allocate costs internally among the County's various functions. The County's internal service fund reports on the County self-insurance program for employee medical benefits.

***Fiduciary Funds*** - Fiduciary funds are used to account for resources held for the benefit of parties outside the County. Fiduciary funds are not reflected in the government-wide financial statements because the resources of those funds are not available to support the County's own programs. The accounting used for fiduciary funds is much like that used for proprietary funds. The County's fiduciary funds are a private purpose trust and agency funds.

This space intentionally left blank.

**MIAMI COUNTY, OHIO**

**Management's Discussion and Analysis  
For the Year Ended December 31, 2004**

**Unaudited**

**FINANCIAL ANALYSIS OF THE COUNTY AS A WHOLE**

This is the second year for government-wide financial statements using the full accrual basis of accounting. The table below provides a comparison of 2004 to 2003 for both the Governmental and Business-type activities.

	Governmental Activities		Business-type Activities		Total	
	Restated		2004	2003	2004	2003
	2004	2003				
Current and other assets	\$74,636,083	\$68,387,417	\$2,766,603	\$1,534,172	\$77,402,686	\$69,921,589
Capital assets, Net	79,799,548	79,409,085	13,613,645	11,529,466	93,413,193	90,938,551
Total assets	154,435,631	147,796,502	16,380,248	13,063,638	170,815,879	160,860,140
Long-term debt outstanding	12,568,293	13,303,925	5,631,932	6,029,603	18,200,225	19,333,528
Other liabilities	16,173,253	14,598,948	3,399,370	523,108	19,572,623	15,122,056
Total liabilities	28,741,546	27,902,873	9,031,302	6,552,711	37,772,848	34,455,584
Net assets						
Invested in capital assets, net of related debt	72,650,169	72,021,370	5,519,649	5,877,948	78,169,818	77,899,318
Restricted	34,146,735	29,055,735	0	0	34,146,735	29,055,735
Unrestricted	18,897,181	18,816,524	1,829,297	632,979	20,726,478	19,449,503
Total net assets	\$125,694,085	\$119,893,629	\$7,348,946	\$6,510,927	\$133,043,031	\$126,404,556

This space intentionally left blank.



**MIAMI COUNTY, OHIO**

**Management's Discussion and Analysis  
For the Year Ended December 31, 2004**

**Unaudited**

**Changes in Net Assets** – The following table shows the changes in net assets for the fiscal years 2004 and 2003:

	Governmental Activities		Business-type Activities		Total	
	2004	2003	2004	2003	2004	2003
Revenues						
Program Revenues:						
Charges for Services and Sales	\$14,975,188	\$15,744,054	\$7,176,182	\$6,807,299	\$22,151,370	\$22,551,353
Operating Grants and Contributions	17,327,623	17,408,897	0	0	17,327,623	17,408,897
Capital Grants and Contributions	6,778,362	1,079,269	91,626	0	6,869,988	1,079,269
General Revenues:						
Property Taxes	12,098,988	11,644,400	0	0	12,098,988	11,644,400
Sales Taxes	10,448,932	9,648,557	0	0	10,448,932	9,648,557
Shared Revenues	3,678,939	2,873,288	0	0	3,678,939	2,873,288
Investment Earnings	781,755	856,489	7,055	4,485	788,810	860,974
Miscellaneous	645,128	335,284	0	0	645,128	335,284
Total revenues	<u>66,734,915</u>	<u>59,590,238</u>	<u>7,274,863</u>	<u>6,811,784</u>	<u>74,009,778</u>	<u>66,402,022</u>
Program Expenses:						
Public Safety	16,764,256	15,547,338	0	0	16,764,256	15,547,338
Health	10,547,505	9,718,113	0	0	10,547,505	9,718,113
Human Services	12,487,729	12,136,393	0	0	12,487,729	12,136,393
Conservation and Recreation	484,357	449,267	0	0	484,357	449,267
Public Works	6,634,587	6,376,942	0	0	6,634,587	6,376,942
General Government	13,705,416	13,372,441	0	0	13,705,416	13,372,441
Interest and Fiscal Charges	310,609	332,390	0	0	310,609	332,390
Business Type Activities:						
Water	0	0	1,124,739	872,925	1,124,739	872,925
Sewer	0	0	1,268,242	1,463,920	1,268,242	1,463,920
Transfer Station	0	0	3,907,615	4,711,489	3,907,615	4,711,489
Sheriff Police Rotary	0	0	136,248	133,718	136,248	133,718
Total expenses	<u>60,934,459</u>	<u>57,932,884</u>	<u>6,436,844</u>	<u>7,182,052</u>	<u>67,371,303</u>	<u>65,114,936</u>
Total Change in Net Assets	5,800,456	1,657,354	838,019	(370,268)	6,638,475	1,287,086
Beginning Net Assets - Restated	<u>119,893,629</u>	<u>118,236,275</u>	<u>6,510,927</u>	<u>6,881,195</u>	<u>126,404,556</u>	<u>125,117,470</u>
Ending Net Assets	<u>\$125,694,085</u>	<u>\$119,893,629</u>	<u>\$7,348,946</u>	<u>\$6,510,927</u>	<u>\$133,043,031</u>	<u>\$126,404,556</u>

This space intentionally left blank.

**MIAMI COUNTY, OHIO**

**Management's Discussion and Analysis  
For the Year Ended December 31, 2004**

**Unaudited**

**Governmental Activities**

Net assets of the County's governmental activities increased by \$5,800,456. This was primarily a result of increased capital grant revenues. Federal monies have been provided for a number of road and bridge projects throughout the County.

Tax revenue accounts for \$22,547,920 of the \$66,734,915 in total revenues for governmental activities. Property tax accounted for \$12,098,988, or approximately 53.65% of total tax revenue.

The County's net charges to users of governmental services totaled \$21,853,286. This amount was subsidized by the County's general revenues of \$27,653,742.

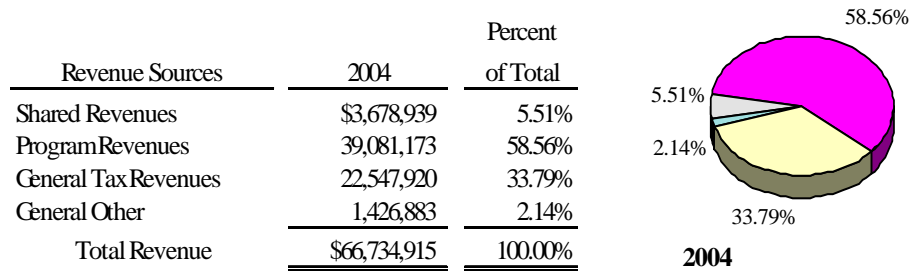

**Business-Type Activities**

Net assets of the business-type activities increased by \$838,019. This increase is attributable to increased operating revenues in the Water and Sewer Funds coupled with decreased expense levels in the Sewer and Transfer Station Funds. These programs had revenues of \$7,274,863 and expenses of \$6,436,844 for fiscal year 2004. Business-type activities receive no support from tax revenues and remain self-supporting.

**FINANCIAL ANALYSIS OF THE COUNTY'S FUNDS**

The County's governmental funds reported a combined fund balance of \$40,952,430, which is a decrease from last year's total of \$41,677,415. The schedule below indicates the fund balance and the total change in fund balance by major fund (Other Governmental fund) as of December 31, 2004 and 2003.

	Fund Balance December 31, 2004	Fund Balance December 31, 2003	Increase (Decrease)
General	\$17,085,732	\$17,847,389	(\$761,657)
Motor Vehicle and Gasoline Tax	2,318,119	1,916,433	401,686
Job and Family Services	1,057,470	1,152,989	(95,519)
Mental Retardation and Developmental Disabilities Board	6,012,534	6,381,332	(368,798)
Other Governmental	14,478,575	14,379,272	99,303
<b>Total</b>	<b>\$40,952,430</b>	<b>\$41,677,415</b>	<b>(\$724,985)</b>

**MIAMI COUNTY, OHIO**

**Management's Discussion and Analysis  
For the Year Ended December 31, 2004**

**Unaudited**

*General Fund* – The County's General Fund revenues were exceeded by the fund's expenditures by \$354,465. The General Fund's balance decreased (overall) by \$761,657. The tables that follow assist in illustrating the financial activities and balance of the General Fund:

	2004 Revenues	2003 Revenues	Increase (Decrease)
Taxes	\$12,537,510	\$11,179,290	\$1,358,220
Intergovernmental Revenues	3,016,651	2,613,275	403,376
Charges for Services	4,943,958	4,799,896	144,062
Licenses and Permits	536,159	482,030	54,129
Investment Earnings	730,910	920,073	(189,163)
Fines and Forfeitures	1,103,811	1,343,830	(240,019)
All Other Revenue	418,107	364,216	53,891
<b>Total</b>	<b>\$23,287,106</b>	<b>\$21,702,610</b>	<b>\$1,584,496</b>

The \$1,584,796 overall increase in revenues is mainly due to large increase in tax revenues related to higher receipts of both property and sales tax revenues.

	2004 Expenditures	2003 Expenditures	Increase (Decrease)
Public Safety	\$9,881,044	\$9,596,298	\$284,746
Health	196,367	193,201	3,166
Human Services	1,860,037	1,823,337	36,700
Conservation and Recreation	436,907	404,451	32,456
Public Works	808,297	36,131	772,166
General Government	10,458,919	9,939,595	519,324
<b>Total</b>	<b>\$23,641,571</b>	<b>\$21,993,013</b>	<b>\$1,648,558</b>

The expenditures increased by \$1,648,558 or 7.5% over the prior year. This is the main result of routine increases in personnel, salaries and fringe benefits along with price increases for goods and services used by employees.

*Motor Vehicle and Gasoline Tax Fund* – Revenues increased by 10.5% over 2003 while expenditure increases were limited to a 4.3% increase. The fund balance increased by \$401,686 in 2003.

*Job and Family Services Fund* – Revenues decreased by 13.6% under 2003 while expenditure decreases were limited to only a 7.1% decrease. The fund balance decreased by \$95,519 in 2004.

*Mental Retardation and Developmental Disabilities Board Fund* – Revenues increased by 5.4% over 2003 while expenditure increases were a 7.3% increase. The fund balance decreased by \$368,798 in 2003.

**MIAMI COUNTY, OHIO**

---

**Management's Discussion and Analysis  
For the Year Ended December 31, 2004**

**Unaudited**

---

The County's budget is prepared according to Ohio law and is based on accounting for certain transactions on a basis of cash receipts, disbursements and encumbrances. The most significant budgeted fund is the General Fund.

During the course of fiscal year 2004 the County amended its General Fund budget several times, none significant.

For the General Fund, budget basis revenue of \$20.1 million increased by \$1 million when compared to the original budget estimates. Increased tax revenue collections allowed for an increase in revenue estimates, which in turn allowed for increased appropriation authority. The General Fund had an adequate fund balance to cover expenditures.

**CAPITAL ASSETS AND DEBT ADMINISTRATION**

**Capital Assets**

At the end of fiscal 2004 the County had \$93,413,193 net of accumulated depreciation invested in capital assets for its governmental and business-type activities. Of this total, \$79,799,548 was related to governmental activities and \$13,613,645 to the business-type activities.

Governmental activities largest increase occurred in the buildings category. Large capital outlays for renovations of existing buildings accounted for the majority of the increase.

Acquisitions in the business-type activities amounted to \$2,931,965. The sewer fund accounted for 59% of the total acquisitions.

The following table summarizes the County's capital assets as of December 31, 2004 and December 31, 2003:

	Governmental Activities		Increase (Decrease)
	2004	2003	
Land	\$5,549,402	\$5,492,186	\$57,216
Construction in Progress	695,257	10,323,593	(9,628,336)
Total Non-Depreciable Capital Assets	6,244,659	15,815,779	(9,571,120)
Buildings	35,285,165	26,828,483	8,456,682
Improvements Other Than Buildings	256,391	237,243	19,148
Machinery and Equipment	20,478,963	18,093,940	2,385,023
Infrastructure	61,023,662	59,245,921	1,777,741
Less: Accumulated Depreciation	(43,489,292)	(40,812,281)	(2,677,011)
Total Depreciable Capital Assets	73,554,889	63,593,306	9,961,583
Totals	\$79,799,548	\$79,409,085	\$390,463

**MIAMI COUNTY, OHIO**

**Management's Discussion and Analysis  
For the Year Ended December 31, 2004**

**Unaudited**

	Business-Type Activities		Increase (Decrease)
	2004	2003	
Land	\$90,000	\$90,000	\$0
Construction in Progress	2,061,655	438,818	1,622,837
Total Non-Depreciable Capital Assets	<u>2,151,655</u>	<u>528,818</u>	<u>1,622,837</u>
Buildings	2,486,972	2,479,272	7,700
Improvements Other Than Buildings	12,793,172	11,967,925	825,247
Machinery and Equipment	1,402,352	1,364,988	37,364
Less: Accumulated Depreciation	<u>(5,220,506)</u>	<u>(4,811,537)</u>	<u>(408,969)</u>
Total Non-Depreciable Capital Assets	<u>11,461,990</u>	<u>11,000,648</u>	<u>461,342</u>
Totals	<u>\$13,613,645</u>	<u>\$11,529,466</u>	<u>\$2,084,179</u>

Additional information on the County's capital assets can be found in Note 9.

**Debt**

At December 31, 2004, the County had \$11.9 million in bonds outstanding, \$880,000 due within one year. The following table summarizes the County's debt outstanding as of December 31, 2004 and December 31, 2003:

	2004	2003
Governmental Activities:		
General Obligation Bonds	\$7,050,000	\$7,560,000
Superfund Site Liability	2,914,659	3,189,768
Capital Leases	99,379	152,715
Compensated Absences	2,504,255	2,401,442
Total Governmental Activities	<u>12,568,293</u>	<u>13,303,925</u>
Business-Type Activities:		
General Obligation Bonds	4,890,000	5,225,000
Loans	621,000	665,600
Landfill Postclosure Care Liability	24,094	23,599
Compensated Absences	96,838	115,404
Total Business-Type Activities	<u>5,631,932</u>	<u>6,029,603</u>
Totals	<u>\$18,200,225</u>	<u>\$19,333,528</u>

State statutes limit the amount of unvoted general obligation debt the County may issue. The aggregate amount of the County's unvoted debt is also subject to overlapping debt restrictions with other political subdivisions. The actual aggregate amount of the County's unvoted debt, when added to that of other political subdivisions within the County, is limited to ten mills. At December 31, 2004, the County's outstanding debt was below the legal limit. Additional information on the County's long-term debt can be found in Note 13.

## **MIAMI COUNTY, OHIO**

---

*Management's Discussion and Analysis  
For the Year Ended December 31, 2004*

*Unaudited*

---

### **ECONOMIC FACTORS AND NEXT YEAR'S BUDGETS AND RATES**

Unemployment rates have risen nation-wide, however Miami County's employment rate has continued, since 1990, to be better than both the state and national rate. During 2004 the County had a 5.7% unemployment rate as compared to a 6.0% national rate and a statewide rate of 6.1%.

The Ohio Department of Development estimates our current population to be at 98,868. We have had a 6.1% increase in population since 1990. We have an average household income of \$59,519 and a median income of \$47,691.

The economic downturn that the Country has recently experienced has certainly had an impact on all levels of state and local government. The County's budget for the general fund in 2005 is very conservative. County management had projected revenues for 2005 to be \$21.2 million, which is 12.43% less than was actually received in fiscal year 2004. The County did not project any change in sales tax for 2004.

The County Commissioners continue to pursue new revenue sources. If the current economic conditions continue, it will be imperative to take further action to increase revenue in order to maintain fiscal stability.

### **REQUESTS FOR INFORMATION**

This financial report is designed to provide our citizens, taxpayers, investors and creditors with a general overview of the County's finances and to show the County's accountability for the money it receives. If you have questions about this report or need additional financial information contact Chris A. Peoples, Miami County Auditor, 201 W. Main Street, Troy, Ohio 45373.

**MIAMI COUNTY, OHIO**

**Statement of Net Assets**  
**December 31, 2004**

	<u>Primary Government</u>			<u>Component Unit</u>
	<u>Governmental Activities</u>	<u>Business-Type Activities</u>	<u>Total</u>	<u>Riverside Training Industries, Inc.</u>
<b>Assets:</b>				
Cash and Cash Equivalents	\$ 14,711,322	\$ 1,083,195	\$ 15,794,517	\$ 227,270
Investments	25,246,199	852,958	26,099,157	813,415
Receivables:				
Taxes	14,307,349	0	14,307,349	0
Accounts	388,553	489,113	877,666	151,174
Intergovernmental	18,771,174	85,004	18,856,178	0
Interest	287,702	1,643	289,345	0
Loans	584,380	0	584,380	0
Internal Balances	(32,036)	32,036	0	0
Due from Component Unit	27	0	27	0
Inventory of Supplies at Cost	184,455	0	184,455	2,518
Prepaid Items	186,958	650	187,608	3,416
Non-Depreciable Capital Assets	6,244,659	2,151,655	8,396,314	130,000
Depreciable Capital Assets, Net	73,554,889	11,461,990	85,016,879	1,130,379
Deferred Loss on Early Retirement of Debt	0	222,004	222,004	0
<b>Total Assets</b>	<b>154,435,631</b>	<b>16,380,248</b>	<b>170,815,879</b>	<b>2,458,172</b>
<b>Liabilities:</b>				
Accounts Payable	2,221,364	395,208	2,616,572	6,858
Accrued Wages and Benefits	1,563,631	47,826	1,611,457	45,980
Intergovernmental Payable	92,366	105,664	198,030	0
Claims Payable	531,352	0	531,352	0
Due to Others	0	0	0	1,256
Due to Primary Government	0	0	0	27
Deferred Revenue	11,736,860	0	11,736,860	0
Accrued Interest Payable	27,680	45,672	73,352	0
General Obligation Notes Payable	0	2,805,000	2,805,000	0
Long Term Liabilities:				
Due Within One Year	2,034,228	450,409	2,484,637	0
Due in More Than One Year	10,534,065	5,181,523	15,715,588	0
<b>Total Liabilities</b>	<b>28,741,546</b>	<b>9,031,302</b>	<b>37,772,848</b>	<b>54,121</b>
<b>Net Assets:</b>				
Invested in Capital Assets, Net of Related Debt	72,650,169	5,519,649	78,169,818	1,260,379
Restricted For:				
Capital Projects	4,105,208	0	4,105,208	0
Debt Service	62,202	0	62,202	0
Other Purposes	29,979,325	0	29,979,325	0
Unrestricted	18,897,181	1,829,297	20,726,478	1,143,672
<b>Total Net Assets</b>	<b>\$ 125,694,085</b>	<b>\$ 7,348,946</b>	<b>\$ 133,043,031</b>	<b>\$ 2,404,051</b>

See accompanying notes to the basic financial statements

**MIAMI COUNTY, OHIO**

**Statement of Activities  
For the Year Ended December 31, 2004**

	<b>Program Revenues</b>			
<b>Expenses</b>	<b>Charges for Services and Sales</b>	<b>Operating Grants and Contributions</b>	<b>Capital Grants and Contributions</b>	
<b>Governmental Activities:</b>				
Public Safety	\$ 16,764,256	\$ 5,353,798	\$ 2,277,537	\$ 0
Health	10,547,505	390,591	1,879,994	0
Human Services	12,487,729	2,320,136	8,765,609	0
Conservation and Recreation	484,357	0	0	0
Public Works	6,634,587	920,648	3,796,927	6,778,362
General Government	13,705,416	5,990,015	607,556	0
Interest and Fiscal Charges	310,609	0	0	0
<b>Total Governmental Activities</b>	<b>60,934,459</b>	<b>14,975,188</b>	<b>17,327,623</b>	<b>6,778,362</b>
<b>Business-Type Activities:</b>				
Water	1,124,739	1,004,109	0	15,272
Sewer	1,268,242	1,268,253	0	76,354
Transfer Station	3,907,615	4,734,357	0	0
Sheriff Police Rotary	136,248	169,463	0	0
<b>Total Business-Type Activities</b>	<b>6,436,844</b>	<b>7,176,182</b>	<b>0</b>	<b>91,626</b>
<b>Total Primary Government</b>	<b>\$ 67,371,303</b>	<b>\$ 22,151,370</b>	<b>\$ 17,327,623</b>	<b>\$ 6,869,988</b>
<b>Component Unit:</b>				
Riverside Training Industries, Inc.	\$ 1,309,522	\$ 1,179,737	\$ 172,572	\$ 0
<b>General Revenues:</b>				
Property Taxes				
Sales Taxes				
Shared Revenues				
Investment Earnings				
Miscellaneous				
Total General Revenues				
Change in Net Assets				
Net Assets Beginning of Year, Restated				
Net Assets End of Year				

See accompanying notes to the basic financial statements



**MIAMI COUNTY, OHIO**

---

Net (Expense) Revenue and Changes in Net Assets			
Primary Government			Component Unit
Governmental Activities	Business-Type Activities	Total	Riverside Training Industries, Inc.
\$ (9,132,921)	\$ 0	\$ (9,132,921)	
(8,276,920)	0	(8,276,920)	
(1,401,984)	0	(1,401,984)	
(484,357)	0	(484,357)	
4,861,350	0	4,861,350	
(7,107,845)	0	(7,107,845)	
(310,609)	0	(310,609)	
(21,853,286)	0	(21,853,286)	
0	(105,358)	(105,358)	
0	76,365	76,365	
0	826,742	826,742	
0	33,215	33,215	
0	830,964	830,964	
(21,853,286)	830,964	(21,022,322)	
			\$ 42,787
12,098,988	0	12,098,988	0
10,448,932	0	10,448,932	0
3,678,939	0	3,678,939	0
781,755	7,055	788,810	53,326
645,128	0	645,128	0
27,653,742	7,055	27,660,797	53,326
5,800,456	838,019	6,638,475	96,113
119,893,629	6,510,927	126,404,556	2,307,938
\$ 125,694,085	\$ 7,348,946	\$ 133,043,031	\$ 2,404,051

**MIAMI COUNTY, OHIO**

**Balance Sheet**  
**Governmental Funds**  
**December 31, 2004**

	General	Motor Vehicle and Gasoline Tax	Job and Family Services
	<u>                    </u>	<u>                    </u>	<u>                    </u>
<b>Assets:</b>			
Cash and Cash Equivalents	\$ 663,569	\$ 1,142,710	\$ 321,597
Investments	14,712,432	1,268,820	358,514
Receivables:			
Taxes	6,098,120	626,852	0
Accounts	135,455	176,052	0
Intergovernmental	2,406,268	8,303,629	4,314,365
Interest	258,153	3,286	0
Loans	0	0	0
Due from Other Funds	68,684	17,099	56,373
Interfund Loans Receivable	15,468	0	0
Due from Component Unit	0	0	0
Inventory of Supplies, at Cost	0	184,455	0
Prepaid Items	127,020	10,450	12,319
<b>Total Assets</b>	<u><u>\$ 24,485,169</u></u>	<u><u>\$ 11,733,353</u></u>	<u><u>\$ 5,063,168</u></u>
<b>Liabilities:</b>			
Accounts Payable	\$ 319,762	\$ 873,795	\$ 163,776
Accrued Wages and Benefits Payable	659,890	125,804	79,212
Intergovernmental Payable	23,006	0	15,411
Due to Other Funds	24,938	1,199	66,824
Interfund Loans Payable	0	0	0
Deferred Revenue	6,371,841	8,414,436	3,680,475
<b>Total Liabilities</b>	<u><u>7,399,437</u></u>	<u><u>9,415,234</u></u>	<u><u>4,005,698</u></u>
<b>Fund Balances:</b>			
Reserved for Encumbrances	761,200	224,215	63,335
Reserved for Prepaid Items	127,020	10,450	12,319
Reserved for Supplies Inventory	0	184,455	0
Reserved for Debt Service	0	0	0
Reserved for Loans Receivable	15,468	0	0
Undesignated, Unreserved in:			
General Fund	16,182,044	0	0
Special Revenue Funds	0	1,898,999	981,816
Capital Projects Funds	0	0	0
<b>Total Fund Balances</b>	<u><u>17,085,732</u></u>	<u><u>2,318,119</u></u>	<u><u>1,057,470</u></u>
<b>Total Liabilities and Fund Balances</b>	<u><u>\$ 24,485,169</u></u>	<u><u>\$ 11,733,353</u></u>	<u><u>\$ 5,063,168</u></u>

See accompanying notes to the basic financial statements

**MIAMI COUNTY, OHIO**

---

Mental Retardation and Developmental Disabilities Board	Other Governmental Funds	Total Governmental Funds
\$ 1,781,774	\$ 10,094,163	\$ 14,003,813
3,978,412	4,139,298	24,457,476
7,173,917	408,460	14,307,349
0	77,046	388,553
1,018,652	2,728,260	18,771,174
20,417	5,846	287,702
0	584,380	584,380
0	74,098	216,254
0	0	15,468
27	0	27
0	0	184,455
37,169	0	186,958
<u>\$ 14,010,368</u>	<u>\$ 18,111,551</u>	<u>\$ 73,403,609</u>
\$ 92,453	\$ 771,578	\$ 2,221,364
296,058	402,667	1,563,631
435	53,514	92,366
0	155,329	248,290
0	15,468	15,468
7,608,888	2,234,420	28,310,060
<u>7,997,834</u>	<u>3,632,976</u>	<u>32,451,179</u>
99,421	729,495	1,877,666
37,169	0	186,958
0	0	184,455
0	89,505	89,505
0	584,380	599,848
0	0	16,182,044
5,875,944	8,994,459	17,751,218
0	4,080,736	4,080,736
<u>6,012,534</u>	<u>14,478,575</u>	<u>40,952,430</u>
<u>\$ 14,010,368</u>	<u>\$ 18,111,551</u>	<u>\$ 73,403,609</u>

**MIAMI COUNTY, OHIO**

---

***Reconciliation Of Total Governmental Fund Balances  
To Net Assets Of Governmental Activities  
December 31, 2004***

---

<b>Total Governmental Fund Balances</b>	\$ 40,952,430
<b><i>Amounts reported for governmental activities in the statement of net assets are different because:</i></b>	
Capital Assets used in governmental activities are not resources and therefore are not reported in the funds.	79,799,548
Other long-term assets are not available to pay for current period expenditures and therefore are deferred in the funds.	16,573,200
Long-term liabilities, including bonds payable, are not due and payable in the current period and therefore are not reported in the funds.	(12,595,973)
The Internal Service Fund is used by management to charge the costs of insurance to individual funds. The assets and liabilities of the internal service funds is included in governmental activities in the statement of net assets. This is the balance that is recorded in the governmental activities.	<u>964,880</u>
<b><i>Net Assets of Governmental Funds</i></b>	<u><u>\$ 125,694,085</u></u>

See accompanying notes to the basic financial statements



**MIAMI COUNTY, OHIO**

**Statement of Revenues, Expenditures and Changes in Fund Balances  
Governmental Funds  
For the Year Ended December 31, 2004**

	General	Motor Vehicle and Gasoline Tax	Job and Family Services
	<u>                    </u>	<u>                    </u>	<u>                    </u>
<b>Revenues:</b>			
Taxes	\$ 12,537,510	\$ 585,535	\$ 0
Intergovernmental Revenues	3,016,651	4,930,667	4,090,931
Charges for Services	4,943,958	366,073	16,030
Licenses and Permits	536,159	0	0
Investment Earnings	730,910	12,319	0
Fines and Forfeitures	1,103,811	76,569	0
All Other Revenues	418,107	93,915	303,875
<b>Total Revenue</b>	<u>23,287,106</u>	<u>6,065,078</u>	<u>4,410,836</u>
<b>Expenditures:</b>			
Current:			
Public Safety	9,881,044	0	0
Health	196,367	0	0
Human Services	1,860,037	0	4,320,181
Conservation and Recreation	436,907	0	0
Public Works	808,297	5,623,079	0
General Government	10,458,919	0	0
Capital Outlay	0	0	0
Debt Service:			
Principal Retirement	0	53,336	0
Interest and Fiscal Charges	0	6,436	0
<b>Total Expenditures</b>	<u>23,641,571</u>	<u>5,682,851</u>	<u>4,320,181</u>
Excess (Deficiency) of Revenues Over Expenditures	(354,465)	382,227	90,655
<b>Other Financing Sources (Uses):</b>			
Transfers In	94,931	0	0
Transfers Out	(502,123)	0	(186,174)
<b>Total Other Financing Sources (Uses)</b>	<u>(407,192)</u>	<u>0</u>	<u>(186,174)</u>
Net Change in Fund Balances	(761,657)	382,227	(95,519)
<b>Fund Balances at Beginning of Year</b>	17,847,389	1,916,433	1,152,989
Increase (Decrease) in Inventory Reserve	0	19,459	0
<b>Fund Balances End of Year</b>	<u>\$ 17,085,732</u>	<u>\$ 2,318,119</u>	<u>\$ 1,057,470</u>

See accompanying notes to the basic financial statements

**MIAMI COUNTY, OHIO**

---

Mental Retardation and Developmental Disabilities Board	Other Governmental Funds	Total Governmental Funds
\$ 6,855,823	\$ 2,353,171	\$ 22,332,039
2,833,087	8,228,255	23,099,591
63,930	7,154,210	12,544,201
0	30	536,189
(10,949)	46,610	778,890
0	144,066	1,324,446
49,648	163,324	1,028,869
<u>9,791,539</u>	<u>18,089,666</u>	<u>61,644,225</u>
0	6,515,780	16,396,824
10,160,337	273,384	10,630,088
0	6,485,998	12,666,216
0	47,450	484,357
0	1,096,657	7,528,033
0	2,708,376	13,167,295
0	636,854	636,854
0	510,000	563,336
0	309,230	315,666
<u>10,160,337</u>	<u>18,583,729</u>	<u>62,388,669</u>
(368,798)	(494,063)	(744,444)
0	993,646	1,088,577
0	(400,280)	(1,088,577)
<u>0</u>	<u>593,366</u>	<u>0</u>
(368,798)	99,303	(744,444)
6,381,332	14,379,272	41,677,415
0	0	19,459
<u>\$ 6,012,534</u>	<u>\$ 14,478,575</u>	<u>\$ 40,952,430</u>

**MIAMI COUNTY, OHIO**

---

***Reconciliation Of The Statement Of Revenues, Expenditures  
And Changes In Fund Balances Of Governmental Funds  
To The Statement Of Activities  
For The Year Ended December 31, 2004***

---

**Net Change in Fund Balances - Total Governmental Funds** \$ (744,444)

***Amounts reported for governmental activities in the statement of activities are different because***

Governmental funds report capital outlays as expenditures. However, in the statement of activities, the cost of those assets is allocated over their estimated useful lives as depreciation expense. This is the amount by which capital outlays and capital contributions exceeded depreciation.	436,697
Governmental funds only report the disposal of assets to the extent proceeds are received from the sale. In the statement of activities, a gain or loss is reported for each disposal. This is the amount of the loss on the disposal of fixed assets net of proceeds received.	(46,234)
Revenues and transfers in the statement of activities that do not provide current financial resources are not reported as revenues in the funds.	5,090,690
The issuance of long-term debt (e.g. capital leases) provides current financial resources to governmental funds, while the repayment of principal of long-term debt consumes current financial resources of governmental funds. Neither transaction, however, has any effect on net assets.	838,445
In the statement of activities, interest is accrued on outstanding bonds, whereas in governmental funds, an interest expenditure is reported when due.	5,057
Some expenses reported in the statement of activities, such as change in inventory and compensated absences, do not require the use of current financial resources and therefore are not reported as expenditures in the governmental funds.	(83,354)
The Internal Service Fund, is used to charge the cost of services (e.g. insurance) to individual funds, is not included in the statement of activities. Governmental fund expenditures and related internal service fund revenues are eliminated. The net revenue (expense) of the County's Internal Service Fund is allocated among the governmental activities.	<u>303,599</u>
<b><i>Change in Net Assets of Governmental Activities</i></b>	<b><u><u>\$ 5,800,456</u></u></b>

See accompanying notes to the basic financial statements



**MIAMI COUNTY, OHIO**

**Statement of Revenues, Expenditures and Changes in  
Fund Balance – Budget and Actual (Non-GAAP Budgetary Basis)  
General Fund  
For the Year Ended December 31, 2004**

	Original Budget	Final Budget	Actual	Variance with Final Budget Positive (Negative)
<b>Revenues:</b>				
Taxes	\$ 10,668,600	\$ 11,404,600	\$ 12,405,253	\$ 1,000,653
Intergovernmental Revenues	2,478,500	2,861,976	3,001,637	139,661
Charges for Services	3,449,700	3,359,700	5,015,796	1,656,096
Licenses and Permits	450,100	450,100	536,159	86,059
Investment Earnings	600,000	600,000	773,422	173,422
Fines and Forfeitures	1,158,000	1,158,000	1,131,089	(26,911)
All Other Revenues	332,700	350,700	427,641	76,941
Total Revenues	19,137,600	20,185,076	23,290,997	3,105,921
<b>Expenditures:</b>				
Current:				
Public Safety	10,584,340	10,751,272	10,149,698	601,574
Health	198,330	198,330	194,529	3,801
Human Services	1,996,782	2,001,843	1,859,459	142,384
Conservation and Recreation	443,300	448,825	448,586	239
Public Works	449,258	910,709	842,797	67,912
General Government	12,027,890	12,162,252	10,968,134	1,194,118
Total Expenditures	25,699,900	26,473,231	24,463,203	2,010,028
Excess (Deficiency) of Revenues Over (Under) Expenditures	(6,562,300)	(6,288,155)	(1,172,206)	5,115,949
<b>Other Financing Sources (Uses):</b>				
Transfers In	0	0	94,931	94,931
Transfers Out	(333,500)	(502,916)	(502,123)	793
Advances In	47,500	47,500	590,572	543,072
Advances Out	0	(555,572)	(555,572)	0
Total Other Financing Sources (Uses):	(286,000)	(1,010,988)	(372,192)	638,796
Net Change in Fund Balance	(6,848,300)	(7,299,143)	(1,544,398)	5,754,745
Fund Balance at Beginning of Year	15,030,562	15,030,562	15,030,562	0
Prior Year Encumbrances	904,027	904,027	904,027	0
Fund Balance at End of Year	\$ 9,086,289	\$ 8,635,446	\$ 14,390,191	\$ 5,754,745

See accompanying notes to the basic financial statements

**MIAMI COUNTY, OHIO**

***Statement of Revenues, Expenditures and Changes in  
Fund Balance – Budget and Actual (Non-GAAP Budgetary Basis)  
Special Revenue Fund – Motor Vehicle and Gasoline Tax Fund  
For the Year Ended December 31, 2004***

	Original Budget	Final Budget	Actual	Variance with Final Budget Positive (Negative)
<b>Revenues:</b>				
Taxes	\$ 614,200	\$ 614,200	\$ 585,535	\$ (28,665)
Intergovernmental Revenues	4,330,000	4,330,000	4,714,289	384,289
Charges for Services	460,000	428,220	393,502	(34,718)
Investment Earnings	25,000	25,000	16,647	(8,353)
Fines and Forfeitures	76,000	76,000	77,678	1,678
All Other Revenues	80,400	80,400	103,265	22,865
Total Revenues	5,585,600	5,553,820	5,890,916	337,096
<b>Expenditures:</b>				
Current:				
Public Works	6,334,934	6,771,811	6,035,981	735,830
Total Expenditures	6,334,934	6,771,811	6,035,981	735,830
Excess (Deficiency) of Revenues Over (Under) Expenditures	(749,334)	(1,217,991)	(145,065)	1,072,926
Fund Balance at Beginning of Year	1,267,730	1,267,730	1,267,730	0
Prior Year Encumbrances	229,161	229,161	229,161	0
Fund Balance at End of Year	\$ 747,557	\$ 278,900	\$ 1,351,826	\$ 1,072,926

See accompanying notes to the basic financial statements

**MIAMI COUNTY, OHIO**

***Statement of Revenues, Expenditures and Changes in  
Fund Balance – Budget and Actual (Non-GAAP Budgetary Basis)  
Special Revenue Fund – Job and Family Services Fund  
For the Year Ended December 31, 2004***

	Original Budget	Final Budget	Actual	Variance with Final Budget Positive (Negative)
<b>Revenues:</b>				
Intergovernmental Revenues	\$ 4,855,000	\$ 5,339,205	\$ 3,966,645	\$ (1,372,560)
Charges for Services	10,000	10,000	16,030	6,030
All Other Revenues	241,100	241,100	303,875	62,775
Total Revenues	5,106,100	5,590,305	4,286,550	(1,303,755)
<b>Expenditures:</b>				
Current:				
Human Services	5,104,083	5,828,189	4,592,415	1,235,774
Total Expenditures	5,104,083	5,828,189	4,592,415	1,235,774
Excess (Deficiency) of Revenues Over (Under) Expenditures	2,017	(237,884)	(305,865)	(67,981)
<b>Other Financing Sources (Uses):</b>				
Transfers Out	(186,175)	(186,175)	(186,174)	1
Total Other Financing Sources (Uses):	(186,175)	(186,175)	(186,174)	1
Net Change in Fund Balance	(184,158)	(424,059)	(492,039)	(67,980)
Fund Balance at Beginning of Year	606,087	606,087	606,087	0
Prior Year Encumbrances	299,990	299,990	299,990	0
Fund Balance at End of Year	\$ 721,919	\$ 482,018	\$ 414,038	\$ (67,980)

See accompanying notes to the basic financial statements

**MIAMI COUNTY, OHIO**

***Statement of Revenues, Expenditures and Changes in  
Fund Balance – Budget and Actual (Non-GAAP Budgetary Basis)  
Special Revenue Fund – Mental Retardation and Developmental Disabilities Fund  
For the Year Ended December 31, 2004***

	Original Budget	Final Budget	Actual	Variance with Final Budget Positive (Negative)
<b>Revenues:</b>				
Taxes	\$ 6,772,695	\$ 6,772,695	\$ 6,855,823	\$ 83,128
Intergovernmental Revenues	2,369,797	2,369,797	2,524,776	154,979
Charges for Services	71,867	71,867	80,747	8,880
Investment Earnings	0	0	2,004	2,004
All Other Revenues	38,378	38,378	44,298	5,920
Total Revenues	9,252,737	9,252,737	9,507,648	254,911
<b>Expenditures:</b>				
Current:				
Health	10,440,386	10,440,384	10,250,813	189,571
Total Expenditures	10,440,386	10,440,384	10,250,813	189,571
Excess (Deficiency) of Revenues Over (Under) Expenditures	(1,187,649)	(1,187,647)	(743,165)	444,482
Fund Balance at Beginning of Year	6,101,447	6,101,447	6,101,447	0
Prior Year Encumbrances	217,857	217,857	217,857	0
Fund Balance at End of Year	\$ 5,131,655	\$ 5,131,657	\$ 5,576,139	\$ 444,482

See accompanying notes to the basic financial statements



**MIAMI COUNTY, OHIO**

**Statement of Net Assets  
Proprietary Funds  
December 31, 2004**

	Business-Type Activities - Enterprise Funds		
	Water	Sewer	Transfer Station
<b>Assets:</b>			
<b>Current Assets:</b>			
Cash and Cash Equivalents	\$ 188,088	\$ 337,973	\$ 427,157
Investments	0	376,769	476,189
Receivables:			
Accounts	64,540	107,239	317,334
Intergovernmental	0	0	0
Interest	0	0	1,643
Due from Other Funds	3,810	30,247	948
Prepaid Items	650	0	0
<b>Total Current Assets</b>	<b>257,088</b>	<b>852,228</b>	<b>1,223,271</b>
<b>Noncurrent Assets:</b>			
Non-Depreciable Capital Assets	990,638	1,081,017	80,000
Depreciable Capital Assets, Net	3,418,037	4,986,855	3,057,098
Deferred Loss on Early Retirement of Debt	31,276	109,975	80,753
<b>Total Noncurrent Assets</b>	<b>4,439,951</b>	<b>6,177,847</b>	<b>3,217,851</b>
<b>Total Assets</b>	<b>4,697,039</b>	<b>7,030,075</b>	<b>4,441,122</b>
<b>Liabilities:</b>			
<b>Current Liabilities:</b>			
Accounts Payable	46,468	108,712	240,028
Accrued Wages and Benefits Payable	7,654	6,788	26,642
Intergovernmental Payable	53,128	50,614	1,922
Claims Payable	0	0	0
Due to Other Funds	0	577	2,392
Accrued Interest Payable	12,682	27,848	5,142
General Obligation Notes Payable	817,500	1,987,500	0
Compensated Absences Payable - Current	21,839	7,770	21,200
General Obligation Bonds - Current	68,132	131,868	155,000
Ohio Public Works Commission Loans Payable - Current	25,000	19,600	0
<b>Total Current Liabilities</b>	<b>1,052,403</b>	<b>2,341,277</b>	<b>452,326</b>
<b>Noncurrent Liabilities</b>			
Compensated Absences Payable	19,127	7,570	19,332
General Obligation Bonds Payable	1,276,917	2,108,083	1,150,000
Ohio Public Works Commission Loans Payable	400,000	176,400	0
Landfill Postclosure Care Liability	0	0	24,094
<b>Total Noncurrent Liabilities</b>	<b>1,696,044</b>	<b>2,292,053</b>	<b>1,193,426</b>
<b>Total Liabilities</b>	<b>2,748,447</b>	<b>4,633,330</b>	<b>1,645,752</b>
<b>Net Assets:</b>			
Invested in Capital Assets, net of debt	1,852,402	1,754,396	1,912,851
Unrestricted	96,190	642,349	882,519
<b>Total Net Assets</b>	<b>\$ 1,948,592</b>	<b>\$ 2,396,745</b>	<b>\$ 2,795,370</b>

See accompanying notes to the basic financial statements

**MIAMI COUNTY, OHIO**

---

		Governmental Activites-	
Sheriff Police Rotary	Total Enterprise Funds	Internal Service Fund	
\$ 129,977	\$ 1,083,195	\$ 707,509	
0	852,958	788,723	
0	489,113	0	
85,004	85,004	0	
0	1,643	0	
0	35,005	0	
0	650	0	
<u>214,981</u>	<u>2,547,568</u>	<u>1,496,232</u>	
0	2,151,655	0	
0	11,461,990	0	
0	222,004	0	
<u>0</u>	<u>13,835,649</u>	<u>0</u>	
<u>214,981</u>	<u>16,383,217</u>	<u>1,496,232</u>	
0	395,208	0	
6,742	47,826	0	
0	105,664	0	
0	0	531,352	
0	2,969	0	
0	45,672	0	
0	2,805,000	0	
0	50,809	0	
0	355,000	0	
0	44,600	0	
<u>6,742</u>	<u>3,852,748</u>	<u>531,352</u>	
0	46,029	0	
0	4,535,000	0	
0	576,400	0	
0	24,094	0	
<u>0</u>	<u>5,181,523</u>	<u>0</u>	
<u>6,742</u>	<u>9,034,271</u>	<u>531,352</u>	
0	5,519,649	0	
208,239	1,829,297	964,880	
<u>\$ 208,239</u>	<u>\$ 7,348,946</u>	<u>\$ 964,880</u>	

**MIAMI COUNTY, OHIO**

**Statement of Revenues, Expenses and Changes in Fund Net Assets**  
**Proprietary Funds**  
**For the Year Ended December 31, 2004**

	Business-Type Activities - Enterprise Funds		
	Water	Sewer	Transfer Station
<b>Operating Revenues:</b>			
Charges for Services	\$ 1,003,164	\$ 1,268,058	\$ 4,697,619
Other Operating Revenue	945	195	36,738
Total Operating Revenues	1,004,109	1,268,253	4,734,357
<b>Operating Expenses:</b>			
Personal Services	205,928	157,586	572,515
Materials and Supplies	611,302	34,896	39,633
Contractual Services	124,054	755,631	3,047,676
Utilities	6,380	19,530	30,385
Depreciation	105,826	160,195	142,948
Health Insurance Claims	0	0	0
Total Operating Expenses	1,053,490	1,127,838	3,833,157
Operating Income (Loss)	(49,381)	140,415	901,200
<b>Nonoperating Revenue (Expenses):</b>			
Investment Earnings	0	0	7,055
Interest and Fiscal Charges	(71,249)	(140,404)	(74,458)
Total Nonoperating Revenues (Expenses)	(71,249)	(140,404)	(67,403)
Income (Loss) Before Contributions	(120,630)	11	833,797
Capital Contributions	15,272	76,354	0
Change in Net Assets	(105,358)	76,365	833,797
Net Assets Beginning of Year	2,053,950	2,320,380	1,961,573
Net Assets End of Year	\$ 1,948,592	\$ 2,396,745	\$ 2,795,370

See accompanying notes to the basic financial statements



**MIAMI COUNTY, OHIO**

---

		Governmental Activities-
Sheriff Police Rotary	Total Enterprise Funds	Internal Service Fund
\$ 169,463	\$ 7,138,304	\$ 5,717,152
<u>0</u>	<u>37,878</u>	<u>12,217</u>
<u>169,463</u>	<u>7,176,182</u>	<u>5,729,369</u>
136,248	1,072,277	0
0	685,831	0
0	3,927,361	754,107
0	56,295	0
0	408,969	0
<u>0</u>	<u>0</u>	<u>4,671,663</u>
<u>136,248</u>	<u>6,150,733</u>	<u>5,425,770</u>
33,215	1,025,449	303,599
0	7,055	0
<u>0</u>	<u>(286,111)</u>	<u>0</u>
<u>0</u>	<u>(279,056)</u>	<u>0</u>
33,215	746,393	303,599
<u>0</u>	<u>91,626</u>	<u>0</u>
33,215	838,019	303,599
<u>175,024</u>	<u>6,510,927</u>	<u>661,281</u>
<u>\$ 208,239</u>	<u>\$ 7,348,946</u>	<u>\$ 964,880</u>

**MIAMI COUNTY, OHIO**

***Statement of Cash Flows  
Proprietary Funds  
For the Year Ended December 31, 2004***

	Business-Type Activities - Enterprise Funds		
	Water	Sewer	Transfer Station
<u>Cash Flows from Operating Activities:</u>			
Cash Received from Customers	\$1,017,835	\$1,263,272	\$4,906,526
Cash Payments for Goods and Services	(749,896)	(878,564)	(3,123,879)
Cash Payments to Employees	(188,868)	(162,895)	(595,794)
Net Cash Provided (Used) by Operating Activities	<u>79,071</u>	<u>221,813</u>	<u>1,186,853</u>
<u>Cash Flows from Noncapital Financing Activities:</u>			
Advances In	0	200,000	100,000
Advances Out	0	(200,000)	(135,000)
Net Cash Used by Noncapital Financing Activities	<u>0</u>	<u>0</u>	<u>(35,000)</u>
<u>Cash Flows from Capital and Related Financing Activities:</u>			
Acquisition and Construction of Assets	(938,155)	(1,301,340)	(41,523)
General Obligation Notes Issued	817,500	1,987,500	0
Principal Paid on General Obligation Bonds	(60,923)	(124,077)	(150,000)
Principal Paid on Ohio Public Works Commission Loan	(25,000)	(19,600)	0
Interest Paid on All Debt	(61,267)	(113,559)	(68,301)
Net Cash Provided (Used) by Capital and Related Financing Activities	<u>(267,845)</u>	<u>428,924</u>	<u>(259,824)</u>
<u>Cash Flows from Investing Activities:</u>			
Purchase of Investments	0	(376,769)	(476,189)
Receipts of Interest	0	0	5,766
Net Cash Used by Investing Activities	<u>0</u>	<u>(376,769)</u>	<u>(470,423)</u>
Net Increase (Decrease) in Cash and Cash Equivalents	(188,774)	273,968	421,606
Cash and Cash Equivalents at Beginning of Year	376,862	64,005	5,551
Cash and Cash Equivalents at End of Year	<u>\$188,088</u>	<u>\$337,973</u>	<u>\$427,157</u>

**MIAMI COUNTY, OHIO**

---

Sheriff Police Rotary	Total	Governmental - Activities Internal Service Fund
\$125,723	\$7,313,356	\$5,730,513
0	(4,752,339)	(5,183,152)
(134,963)	(1,082,520)	0
(9,240)	1,478,497	547,361
0	300,000	0
0	(335,000)	0
0	(35,000)	0
0	(2,281,018)	0
0	2,805,000	0
0	(335,000)	0
0	(44,600)	0
0	(243,127)	0
0	(98,745)	0
0	(852,958)	(255,730)
0	5,766	0
0	(847,192)	(255,730)
(9,240)	497,560	291,631
139,217	585,635	415,878
\$129,977	\$1,083,195	\$707,509

(Continued)

**MIAMI COUNTY, OHIO**

**Statement of Cash Flows**  
**Proprietary Funds**  
**For the Year Ended December 31, 2004**

	Business-Type Activities - Enterprise Funds		
	Water	Sewer	Transfer Station
<b>Reconciliation of Operating Income (Loss) to Net Cash</b>			
<b>Provided (Used) by Operating Activities:</b>			
Operating Income (Loss)	(\$49,381)	\$140,415	\$901,200
Adjustments to Reconcile Operating Income (Loss) to			
Net Cash Provided (Used) by Operating Activities:			
Depreciation Expense	105,826	160,195	142,948
Changes in Assets and Liabilities:			
Decrease in Accounts Receivable	11,540	19,970	171,117
(Increase) Decrease in Due from Other Funds	1,486	(24,951)	(948)
(Increase) Decrease in Intergovernmental Receivable	0	0	1,477
Decrease in Prepaid Items	72	585	171
Increase (Decrease) in Accounts Payable	8,155	14,081	(7,212)
Increase in Accrued Wages and Benefits	497	416	6,125
Increase (Decrease) in Due to Other Funds	(334)	129	724
Increase (Decrease) in Intergovernmental Payables	(15,353)	(83,302)	655
Increase in Claims Payable	0	0	0
Increase (Decrease) in Compensated Absences	16,563	(5,725)	(29,404)
Total Adjustments	128,452	81,398	285,653
Net Cash Provided (Used) by Operating Activities	\$79,071	\$221,813	\$1,186,853

**Schedule of Noncash Investing, Capital and Financing Activities:**

At December 31, 2004, the Water and Sewer Funds had outstanding liabilities of \$32,004, and \$88,500, respectively, for the purchase of certain capital assets. During 2004, the Water and Sewer Funds received \$15,272 and \$76,354, respectively, of fixed assets donated by developers.

See accompanying notes to the basic financial statements

**MIAMI COUNTY, OHIO**

---

Sheriff Police Rotary	Total	Governmental - Activities Internal Service Fund
\$33,215	\$1,025,449	\$303,599
0	408,969	0
0	202,627	1,144
0	(24,413)	0
(43,740)	(42,263)	0
0	828	0
0	15,024	0
1,285	8,323	0
0	519	0
0	(98,000)	0
0	0	242,618
0	(18,566)	0
(42,455)	453,048	243,762
(\$9,240)	\$1,478,497	\$547,361

**MIAMI COUNTY, OHIO**

---

***Statement of Net Assets  
Fiduciary Funds  
December 31, 2004***

---

	Private Purpose Trust	Agency Funds
	<u>          </u>	<u>          </u>
<b>Assets:</b>		
Cash and Cash Equivalents	\$ 218,305	\$ 6,603,970
Investments	0	5,520,106
Receivables:		
Taxes	0	72,909,822
Accounts	0	761,562
Special Assessments	0	1,217,263
<b>Total Assets</b>	<u>218,305</u>	<u>87,012,723</u>
<b>Liabilities:</b>		
Due to Others	<u>0</u>	<u>87,012,723</u>
<b>Total Liabilities</b>	<u>0</u>	<u>87,012,723</u>
<b>Net Assets:</b>		
Unrestricted	<u>218,305</u>	<u>0</u>
<b>Total Net Assets</b>	<u>\$ 218,305</u>	<u>\$ 0</u>

See accompanying notes to the basic financial statements

**MIAMI COUNTY, OHIO**

---

***Statement of Changes in Net Assets  
Fiduciary Funds  
For the Year Ended December 31, 2004***

---

	<u>Private Purpose Trust</u>
<b>Additions:</b>	
Contributions:	
Current Unclaimed Funds	\$ 30,902
Total Additions	<u>30,902</u>
<b>Deductions:</b>	
Refund of Unclaimed Monies	<u>20,764</u>
Total Deductions	<u>20,764</u>
Change in Net Assets	10,138
Net Assets at Beginning of Year	<u>208,167</u>
Net Assets End of Year	<u>\$ 218,305</u>

See accompanying notes to the basic financial statements

***Notes to the Basic Financial Statements  
For the Year Ended December 31, 2004***

---

**NOTE 1 - SUMMARY OF SIGNIFICANT ACCOUNTING POLICIES**

**A. Reporting Entity**

The accompanying basic financial statements comply with the provisions of GASB Statement No. 14, "*The Financial Reporting Entity*," in that the financial statements include all organizations, activities, functions and component units for which the County (the primary government) is financially accountable. Financial accountability is defined as the appointment of a voting majority of a legally separate organization's governing body and either (1) the County's ability to impose its will over the organization, or (2) the potential that the organization will provide a financial benefit to or impose a financial burden on the County. Based on the foregoing, the County's financial reporting entity includes all funds, agencies, boards and commissions that are part of the primary government, which include the following services: public safety, highways and streets, social services, public improvements, planning and zoning, and general administrative services. In addition, the County owns and operates a solid waste transfer facility, a water treatment and distribution system and a wastewater treatment and collection system, all of which are reported as enterprise funds.

***Discretely Presented Component Unit*** - The component unit column in the Statement of Net Assets includes the financial data of the County's component unit. It is reported in a separate column to emphasize that it is legally separate from the county. Riverside Training Industries (RTI) contracts with the County MRDD Board to operate MRDD workshops. The workshops are being presented as a part of the County's reporting entity because it would be misleading to exclude them. Complete financial statements for RTI may be obtained from RTI's administrative offices at 110 Foss Way, Troy, Ohio 45373.

The accounting policies of Miami County, Ohio, conform to generally accepted accounting principles as applicable to governmental units. The accounting policies of the discretely presented component unit (RTI) are consistent with those of the County. The following is a summary of the more significant policies:

**B. Basis of Presentation - Fund Accounting**

The accounting system is organized and operated on the basis of funds each of which is considered a separate accounting entity. The operations of each fund are accounted for with a separate set of self-balancing accounts that comprise its assets, liabilities, fund equity, revenues and expenditures or expenses. The following fund types are used by the County:



---

**MIAMI COUNTY, OHIO**

---

***Notes to the Basic Financial Statements  
For the Year Ended December 31, 2004***

---

**NOTE 1 - SUMMARY OF SIGNIFICANT ACCOUNTING POLICIES (Continued)**

**B. Basis of Presentation - Fund Accounting** (Continued)

***Governmental Funds***

Governmental funds are those funds through which most governmental functions typically are financed. The acquisition, use and balances of the County's expendable financial resources and the related current liabilities (except those accounted for in the proprietary funds) are accounted for through governmental funds. The measurement focus is on determination of "financial flow" (sources and use and balances of financial resources). The following are the County's major governmental funds:

General Fund - represents the general operating fund of the County. It is used to account for all financial resources except those required to be accounted for in another fund. The primary revenue sources are property taxes, sales and use taxes, state and local government fund receipts, investment earnings and charges for service. The general fund balance is available to the County for any purpose provided it is expended or transferred according to the laws of Ohio.

Motor Vehicle and Gasoline Tax Fund - This fund is used to account for revenues derived from a property tax levy, the regular motor vehicle license tax fees, 100% of the fuel taxes and a portion of fines collected by the Miami County Municipal Court. Expenditures are restricted to road, bridge, ditch and storm sewer construction, maintenance and repairs.

Job and Family Services Fund - This fund is for the deposit of all monies received from the state government for the purposes of public assistance programs as prescribed in Chapters 5107 and 5113 of the Ohio Revised Code.

Mental Retardation and Developmental Disabilities (MRDD) Board Fund - This fund is used to account for funds obtained from voted levy, lunch receipts, grants and donations and is used for the Riverside School.

***Proprietary Funds***

All proprietary funds are accounted for on an "economic resources" measurement focus. This measurement focus provides that all assets and all liabilities associated with the operation of these funds are included on the balance sheet. Proprietary fund type operating statements present increases (i.e., revenues) and decreases (i.e., expenses) in net total assets.

Enterprise Funds - These funds are used to account for operations that are financed and operated in a manner similar to private business enterprises - where the intent of the governing body is that the costs (expenses, including depreciation) of providing goods or services to the general public on a continuing basis be financed or recovered primarily through user charges. The County's major enterprise funds are:

Water Fund - This fund is used to account for the operation of the County's water service.

**MIAMI COUNTY, OHIO**

---

***Notes to the Basic Financial Statements  
For the Year Ended December 31, 2004***

---

**NOTE 1 - SUMMARY OF SIGNIFICANT ACCOUNTING POLICIES (Continued)**

**B. Basis of Presentation - Fund Accounting** (Continued)

Sewer Fund – This fund is used to account for the operation of the County’s sanitary sewer service.

Transfer Station Fund - To account for the operation of the County's solid waste removal and disposal activities.

Sheriff Police Rotary Fund – To account for charges levied against other political subdivisions and organizations for police services where the specific intent is to promote public safety and security.

Internal Service Fund - This fund is used to account for health insurance services provided to other departments of the County on a cost-reimbursement basis.

***Fiduciary Funds***

Fiduciary fund reporting focuses on net assets and changes in net assets. The fiduciary category is split into four classifications: pension trust funds, investment trust funds, private-purpose trust funds and agency funds. These funds are used to account for assets held by a governmental unit as an agent for individuals, private organizations or other governmental units and therefore not available to support the County’s own programs. The County’s only trust fund is a private purpose trust that accounts for unclaimed monies. The agency funds are custodial in nature (assets equal liabilities) and do not involve the measurement of results of operation. These funds operate on an accrual basis of accounting.

**C. Basis of Presentation – Financial Statements**

**Government-wide Financial Statements** – The statement of net assets and the statement of activities display information about the County as a whole. These statements include the financial activities of the primary government and its discretely presented component unit, except for fiduciary funds. The statements distinguish between those activities of the County that are governmental and those that are considered business-type activities.

Interfund receivables and payables between governmental and business-type activities have been eliminated in the government-wide Statement of Net Assets. Transfers between governmental funds are eliminated on the government-wide Statement of Activities. These eliminations minimize the duplicating effect on assets, liabilities, revenues, and expenditures within the governmental and business-type activities total column.

The government-wide statements are prepared using the economic resources measurement focus. This is the same approach used in the preparation of the proprietary fund financial statements but differs from the manner in which governmental fund financial statements are prepared. Governmental fund financial statements therefore include a reconciliation with brief explanations to better identify the relationship between the government-wide statements and the statements for governmental funds.

***Notes to the Basic Financial Statements  
For the Year Ended December 31, 2004***

---

**NOTE 1 - SUMMARY OF SIGNIFICANT ACCOUNTING POLICIES (Continued)**

**C. Basis of Presentation – Financial Statements (Continued)**

The government-wide statement of activities presents a comparison between direct expenses and program revenues for each segment of the business-type activities of the County and for each function or program of the County's governmental activities. Direct expenses are those that are specifically associated with a service, program or department and therefore clearly identifiable to a particular function. Program revenues include charges paid by the recipient of the goods or services offered by the program and grants and contributions that are restricted to meeting the operational or capital requirements of a particular program. Revenues which are not classified as program revenues are presented as general revenues of the County, with certain limited exceptions. The comparison of direct expenses with program revenues identifies the extent to which each business segment or governmental function is self-financing or draws from the general revenues of the County.

**Fund Financial Statements** – Fund financial statements report detailed information about the County. The focus of governmental fund financial statements is on major funds rather than reporting funds by type. Each major fund is presented in a separate column. Nonmajor funds are aggregated and presented in a single column. Fiduciary funds are reported by fund type.

The accounting and financial reporting treatment applied to a fund is determined by its measurement focus. All governmental fund types are accounted for using a flow of current financial resources measurement focus. The financial statements for governmental funds are a balance sheet, which generally includes only current assets and current liabilities, and a statement of revenues, expenditures and changes in fund balances, which reports on the sources (i.e., revenues and other financing sources) and uses (i.e., expenditures and other financing uses) of current financial resources.

All proprietary fund types are accounted for on a flow of economic resources measurement focus. With this measurement focus, all assets and all liabilities associated with the operation of these funds are included on the statement of net assets. The statement of changes in fund net assets presents increases (i.e., revenues) and decreases (i.e., expenses) in net total assets. The statement of cash flows provides information about how the County finances and meets the cash flow needs of its proprietary activities.

**D. Basis of Accounting**

Basis of accounting represents the methodology utilized in the recognition of revenues and expenditures or expenses reported in the financial statements. The accounting and reporting treatment applied to a fund is determined by its measurement focus.

***Notes to the Basic Financial Statements  
For the Year Ended December 31, 2004***

---

**NOTE 1 - SUMMARY OF SIGNIFICANT ACCOUNTING POLICIES (Continued)**

**D. Basis of Accounting** (Continued)

The modified accrual basis of accounting is followed by the governmental funds. Under the modified accrual basis of accounting, revenues are recorded when susceptible to accrual, i.e., both measurable and available. The term "available" means collectible within the current period or soon enough thereafter to be used to pay liabilities of the current period, which the County considers to be 60 days after year end. Expenditures are recognized in the accounting period in which the fund liability is incurred, if measurable, except for debt service and expenditures related to compensated absences which are recorded only when due.

Non-exchange transactions, in which the County receives value without directly giving equal value in return, include sales and use taxes, property taxes, grants, entitlements and donations. Revenue from sales and use taxes is recognized in the period in which the income is earned and is available. Revenue from grants, entitlements and donations is recognized in the fiscal year in which all eligibility requirements have been satisfied and the revenue is available. Eligibility requirements include timing requirements, which specify the year when the resources are required to be used or the year when use is first permitted, matching requirements, in which the County must provide local resources to be used for a specific purpose, and expenditure requirements, in which the resources are provided to the County on a reimbursement basis. Revenues considered susceptible to accrual at year end include interest on investments, and state levied locally shared taxes, including motor vehicle license fees and local government assistance. Other revenues, including licenses, permits, certain charges for services, and miscellaneous revenues are recorded when received in cash, because generally these revenues are not measurable until received.

Property taxes measurable as of December 31, 2004 but which are not intended to finance 2004 operations and delinquent property taxes, whose availability is indeterminate, are recorded as deferred revenues.

The accrual basis of accounting is utilized for reporting purposes by the proprietary funds and fiduciary funds. Revenues are recognized when they are earned and expenses are recognized when they are incurred.

Pursuant to GASB Statement No. 20, "Accounting and Financial Reporting for Proprietary Funds and Other Governmental Entities that use Proprietary Fund Accounting," the County follows GASB guidance as applicable to proprietary funds and FASB Statements and Interpretations, Accounting Principles Board Opinions and Accounting Research Bulletins issued on or before November 30, 1989 that do not conflict with or contradict GASB pronouncements. The County has elected not to apply FASB statements and interpretations issued after November 30, 1989 to its business-type activities and enterprise funds.

***Notes to the Basic Financial Statements  
For the Year Ended December 31, 2004***

---

**NOTE 1 - SUMMARY OF SIGNIFICANT ACCOUNTING POLICIES (Continued)**

**E. Budgetary Process**

The budgetary process is prescribed by provisions of the Ohio Revised Code and entails the preparation of budgetary documents within an established timetable. The major documents prepared are the tax budget, the certificate of estimated resources and the appropriations resolution, all of which are prepared on the budgetary basis of accounting. The certificate of estimated resources and the appropriations resolution are subject to amendment throughout the year.

All funds, other than agency funds, are legally required to be budgeted and appropriated; however, only the General and major special revenue funds to be reported. The primary level of budget control is at the object level by organizational unit and/or department by function (Public Safety, Public Works, General Government, Debt Service etc.) within a fund. Budgetary modifications may only be made through resolution of the County Commissioners.

**1. Tax Budget**

By July 15, each County department must submit an annual tax budget for the following fiscal year to the County Commissioners for consideration and passage. The adopted budget is submitted to the County Auditor, as secretary of the County Budget Commission, by July 20th of each year, for the period January 1 to December 31 of the following year.

**2. Estimated Resources**

The County Budget Commission determines if the budget substantiates a need to levy all or part of previously authorized taxes and reviews estimated revenue. The Budget Commission then certifies its actions to the County by September 1st of each year. As part of the certification process the County receives an official certificate of estimated resources which states the projected receipts by fund. Prior to December 31, the County must revise its budget so that the total contemplated expenditures from any fund during the ensuing fiscal year will not exceed the amount available as stated in the certificate of estimated resources. The revised budget then serves as the basis for the annual appropriations measure. On or about January 1, the certificate of estimated resources is amended to include any unencumbered fund balances from the preceding year. The certificate may be further amended during the year if a new source of revenue is identified or actual receipts exceed current estimates. The amounts reported on the budgetary statement reflect the amounts in the final amended official certificate of estimated resources issued during 2004.

***Notes to the Basic Financial Statements  
For the Year Ended December 31, 2004***

---

**NOTE 1 - SUMMARY OF SIGNIFICANT ACCOUNTING POLICIES (Continued)**

**E. Budgetary Process** (Continued)

3. Appropriations

A temporary appropriations resolution to control expenditures may be passed on or about January 1st of each year for the period January 1 through March 31. An annual appropriations resolution must be passed by April 1st of each year for the period January 1st through December 31st. The appropriations resolution establishes spending controls at the fund, function, organizational unit and/or department, and object level. The appropriations resolution may be amended during the year by resolution of the County Commissioners as additional information becomes available, provided that total fund appropriations do not exceed the current estimated resources. During 2004, several supplemental appropriations were necessary to budget for unanticipated expenditures. Expenditures may not legally exceed budgeted appropriations at the object level. Administrative control is maintained through the establishment of more detailed line-item budgets. Management may transfer appropriations within the object level (among line items) for an organizational unit and/or department provided total appropriations for that object and organizational unit and/or department do not exceed amounts established by the County Commissioners. The budgetary figures, which appear on the budgetary statements, are provided on the budgetary basis to provide a comparison of actual results with the final budget, including all amendments and modifications.

4. Encumbrances

As part of formal budgetary control, purchase orders, contracts and other commitments for expenditures are encumbered and recorded as the equivalent of expenditures (budget basis) in order to reserve that portion of the applicable appropriation and to determine and maintain legal compliance. However, on the GAAP basis of accounting, encumbrances do not constitute expenditures or liabilities and are reported as reservations of fund balances for governmental funds in the accompanying basic financial statements.

5. Lapsing of Appropriations

At the close of each fiscal year, the unencumbered balance of each appropriation reverts to the respective fund from which it was appropriated and becomes subject to future appropriations. The encumbered appropriations balance is carried forward to the subsequent fiscal year and need not be reappropriated.

6. Budgetary Basis of Accounting

The County's budgetary process accounts for certain transactions on a basis other than generally accepted accounting principles (GAAP). The major difference between the budgetary basis and the GAAP basis lies in the manner in which revenues and expenditures are recorded. Under the budgetary basis, revenues and expenditures are recognized on the cash basis. Utilizing the cash basis, revenues are recorded when received in cash and expenditures when paid. Under the GAAP basis, revenues and expenditures are recorded on the modified accrual basis of accounting.

**MIAMI COUNTY, OHIO**

---

**Notes to the Basic Financial Statements  
For the Year Ended December 31, 2004**

---

**NOTE 1 - SUMMARY OF SIGNIFICANT ACCOUNTING POLICIES (Continued)**

**E. Budgetary Process (Continued)**

6. Budgetary Basis of Accounting (Continued)

A reconciliation of the results of operations for the year from the GAAP basis to the budgetary basis for the general fund and for the major special revenue funds is shown below:

	Net Change in Fund Balances			
	General	Motor Vehicle and Gasoline Tax	Job and Family Services	Mental Retardation and Developmental Disabilities Board
GAAP Basis (as reported)	(\$761,657)	\$382,227	(\$95,519)	(\$368,798)
Increase (Decrease):				
Accrued Revenues at December 31, 2004 received during 2005	(2,583,002)	(707,426)	(690,263)	(596,241)
Accrued Revenues at December 31, 2003 received during 2004	2,621,893	533,264	509,604	312,350
Accrued Expenditures at December 31, 2004 paid during 2005	1,027,596	1,000,798	325,223	388,946
Accrued Expenditures at December 31, 2003 paid during 2004	(830,010)	(279,630)	(274,930)	(284,090)
2003 Prepays for 2004	120,917	912	12,238	33,768
2004 Prepays for 2005	(127,020)	(10,450)	(12,319)	(37,169)
Outstanding Encumbrances	(1,013,115)	(1,064,760)	(266,073)	(191,931)
Budget Basis	<u>(\$1,544,398)</u>	<u>(\$145,065)</u>	<u>(\$492,039)</u>	<u>(\$743,165)</u>

**MIAMI COUNTY, OHIO**

---

***Notes to the Basic Financial Statements  
For the Year Ended December 31, 2004***

---

**NOTE 1 - SUMMARY OF SIGNIFICANT ACCOUNTING POLICIES (Continued)**

**F. Cash and Cash Equivalents**

Cash and cash equivalents include amounts in demand deposits, the State Treasury Asset Reserve of Ohio (STAR Ohio), short-term certificates of deposit and treasury securities. The STAR Ohio, certificates of deposit and treasury securities are considered cash equivalents because they are highly liquid investments or have original maturity dates of three months or less.

The County Treasurer pools cash for investment and resource management purposes. Each fund's equity in pooled cash and investments represents the balance on hand as if each had maintained its own cash and investment account. For purposes of the statement of cash flows, the proprietary funds consider their share of equity in STAR Ohio and pooled certificates of deposit to be cash equivalents. See Note 4 "Cash, Cash Equivalents and Investments."

**G. Investments**

Investment procedures and interest allocations are restricted by provisions of the Ohio Constitution and the Ohio Revised Code. In accordance with GASB Statement No. 31, *Accounting and Financial Reporting for Certain Investments and for External Investment Pools*, the County records all its investments at fair value except for nonparticipating investment contracts (certificates of deposit) which are reported at cost, which approximates fair value. All investment income, including changes in the fair value of investments, are recognized as revenue in the operating statements. Fair value is determined by quoted market prices. See Note 4, "Cash, Cash Equivalents and Investments." During 2004, the County invested funds in U.S. Government Securities, certificates of deposit and STAR Ohio.

STAR Ohio is an investment pool managed by the State Treasurer's Office which allows governments within the State to pool their funds for investment purposes. STAR Ohio is not registered with the SEC as an investment company, but does operate in a manner consistent with Rule 2a7 of the Investment Company Act of 1940. Investments in STAR Ohio are valued at STAR Ohio's share price which is the price the investment could be sold for on December 31, 2004. Riverside Training Industries (discretely presented component unit) permitted investments include stocks, corporate bonds and mutual funds. All investments are valued at share market prices, which are the prices the investments could be sold for on December 31, 2004. See Note 4, "Cash, Cash Equivalents and Investments."

**H. Inventory of Supplies**

Inventory is stated at cost (first-in, first-out) in the governmental funds, and at the lower of cost (first-in, first-out) or market in the proprietary funds. The costs of inventory items are recorded as expenditures in the governmental funds when purchased and expenses in the proprietary funds when used.



***Notes to the Basic Financial Statements  
For the Year Ended December 31, 2004***

---

**NOTE 1 - SUMMARY OF SIGNIFICANT ACCOUNTING POLICIES (Continued)**

**I. Prepaid Items**

Payments made to vendors for services that will benefit periods beyond December 31, 2004, are recorded as prepaid items using the consumption method. A current asset for the prepaid amount is recorded at the time of the purchase and an expenditure/expense is reported in the year in which services are consumed.

**J. Capital Assets and Depreciation**

Capital assets are defined by the County as assets with an initial, individual cost of more than \$1,000.

**1. Property, Plant and Equipment - Governmental Activities**

Governmental Activities capital assets are those not directly related to the business type funds. These generally are acquired or constructed for governmental activities and are recorded as expenditures in the governmental funds and are capitalized at cost or estimated historical cost for assets not purchased in recent years.

Estimated historical costs for governmental activities capital asset values were initially determined by identifying historical costs when such information was available. In cases where information supporting original cost was not obtainable, estimated historical costs were developed. For certain capital assets, the estimates were arrived at by indexing estimated current costs back to the estimated year of acquisition.

Capital assets include land, construction in progress, land improvements, buildings, structures and improvements, furniture, fixtures and equipment and infrastructure. Infrastructure is defined as long-lived capital assets that normally are stationary in nature and normally can be preserved for a significant number of years. Examples of governmental activities infrastructure include roads, bridges, curbs and gutters, streets and sidewalks, drainage systems and lighting systems. These assets are reported in the Governmental Activities column of the Government-wide Statement of Net Assets, but they are not reported in the Fund Financial Statements.

**2. Property, Plant and Equipment – Business Type Activities**

Proprietary funds capital assets are stated at cost (or estimated historical cost), including interest capitalized during construction and architectural and engineering fees where applicable. Contributed capital assets are recorded at fair market value at the date received. Proprietary funds capital assets are similar to Governmental Activities capital assets with the exception of the infrastructure. Proprietary infrastructure consists of water and sewer lines. These assets are reported in both the Business-Type Activities column of the Government-wide Statement of Net Assets and in the respective funds.

**MIAMI COUNTY, OHIO**

---

***Notes to the Basic Financial Statements  
For the Year Ended December 31, 2004***

---

**NOTE 1 - SUMMARY OF SIGNIFICANT ACCOUNTING POLICIES (Continued)**

**J. Capital Assets and Depreciation** (Continued)

3. Depreciation

All capital assets are depreciated, excluding land and construction in progress. Depreciation has been provided using the straight-line method over the following estimated useful lives:

Description	Governmental and Business-Type Activities Estimated Lives (in years)
Land Improvements	20 - 50
Buildings, Structures and Improvements	25 - 60
Machinery, Equipment, Furniture and Fixtures	3 - 20
Infrastructure	10 - 100

**K. Accrued Liabilities and Long-term Obligations**

All payables, accrued liabilities and long-term obligations are reported in the government-wide financial statements, and all payables, accrued liabilities and long-term obligations payable from proprietary funds are reported on the enterprise fund financial statements.

In general, governmental fund payables and accrued liabilities that, once incurred, are paid in a timely manner and in full from current financial resources, are reported as obligations of the funds. However, compensated absences, and contractually required pension contributions that will be paid from governmental funds are reported as a liability in the fund financial statements only to the extent that they are normally due for payment during the current year. Bonds, capital leases, and long-term notes that will be paid from governmental funds are recognized as a liability in the fund financial statements when due.

**L. Long-Term Obligations**

Long-Term liabilities are being repaid from the following funds:

Obligation	Fund
General Obligation Bonds	General Obligation Debt Fund Transfer Station Fund Water Fund Sewer Fund
Superfund Site Liability	Super Cleanup Fund
Ohio Public Works	Water Fund
Commission Loans	Sewer Fund

**MIAMI COUNTY, OHIO**

---

***Notes to the Basic Financial Statements  
For the Year Ended December 31, 2004***

---

**NOTE 1 - SUMMARY OF SIGNIFICANT ACCOUNTING POLICIES (Continued)**

**L. Long-Term Obligations** (Continued)

<u>Obligation</u>	<u>Fund</u>
Capital Lease	Motor Vehicle and Gasoline Tax Fund
Landfill Postclosure Care Liability	Transfer Station Fund
Compensated Absences	General Fund Motor Vehicle and Gasoline Tax Fund Child Support Enforcement Agency Fund Dog and Kennel Fund Job and Family Services Fund Shelter/Domestic Violence Fund Youth Services Subsidy Fund E-911 Emergency Operations Fund Public Defender Fund Delinquent Tax Collection Fund Real Estate Appraisal Fund Pre-Trial Services Fund MRDD Board Fund Community Based Corrections Act Grant Fund Children's Services Board Fund Juvenile Detention/Rehabilitation Center Fund County Probation Services Fund Recycle Grant Fund One-Stop Shop Fund Court Computerization Fund Dispute Resolution Fund Common Pleas Court – Special Projects Fund Water Fund Sewer Fund Transfer Station Fund

**M. Bond Discounts/Issuance Costs**

Bond discounts and issuance costs for governmental and proprietary fund types are deferred and amortized over the term of the bonds using the bonds-outstanding method, which approximates the effective interest method. Bond discounts are presented as a reduction of the face amount of bonds payable, bond premiums are recorded as an increase to the face amount of bonds payable, and issuance costs are recorded as deferred charges.

***Notes to the Basic Financial Statements  
For the Year Ended December 31, 2004***

---

**NOTE 1 - SUMMARY OF SIGNIFICANT ACCOUNTING POLICIES (Continued)**

**N. Compensated Absences**

In accordance with GASB Statement No. 16, "Accounting for Compensated Absences," vacation and compensatory time are accrued as liabilities when an employee's right to receive compensation is attributable to services already rendered and it is probable that the employee will be compensated through paid time off or some other means, such as cash payments, at termination or retirement. Leave time that has been earned but is unavailable for use as paid time off or as some other form of compensation because an employee has not met the minimum service time requirement, is accrued to the extent that it is considered to be probable that the conditions for compensation will be met in the future.

Sick leave is accrued using the vesting method, whereby the liability is recorded on the basis of leave accumulated by employees eligible to receive termination payments as of the balance sheet date, and on leave balances accumulated by other employees expected to become eligible in the future to receive such payments.

For governmental funds, that portion of unpaid compensated absences that is due and payable as of year end using expendable, available resources is reported as an expenditure in the fund from which the individual earning the leave is paid, and a corresponding liability is reflected in the account "Compensated Absences Payable." In the government wide statement of net assets, "Compensated Absences Payable" is recorded within the "Due within one year" account and the long-term portion of the liability is recorded within the "Due in more than one year" account. Compensated absences are expensed in the proprietary funds when earned and the related liability is reported within the fund.

**O. Grants and Other Intergovernmental Revenues**

Local governmental fund revenues are recorded as receivables and revenue when measurable and available. Assistance awards made on the basis of entitlement are recorded as intergovernmental receivables and revenues when entitlement occurs. Federal and State reimbursement-type grants for the acquisition or construction of capital assets in Proprietary funds are receivables and capital contributions when the related expenses are incurred.

All other Federal and State reimbursement-type grants are recorded as receivables and revenues when the related expenditures/expenses are incurred.

**P. Pensions**

The provision for pension costs are recorded when the related payroll is accrued and the obligation is incurred.

***Notes to the Basic Financial Statements  
For the Year Ended December 31, 2004***

---

**NOTE 1 - SUMMARY OF SIGNIFICANT ACCOUNTING POLICIES (Continued)**

**Q. Operating Revenues and Expenses**

Proprietary funds distinguish operating revenues and expenses from nonoperating items. Operating revenues are those revenues that are generated directly from the primary activity of the proprietary funds. For the County, these revenues are charges for services for water treatment and distribution, wastewater collection and treatment, solid waste removal and disposal and policing services to other governments. Operating expenses are necessary costs incurred to provide the good or service that is the primary activity of the fund. All revenues and expenses not meeting this definition are reported as nonoperating revenues and expenses.

**R. Self-Funded Insurance**

The County is self-funded for employee health care benefits. The program is administered by Medical Mutual of Ohio which provides claims review and processing services. Each County fund is charged for its proportionate share of covered employees. The County records a liability in claims payable for incurred but unreported claims at year end based upon an analysis of historical claims and expenses.

**S. Interfund Activity**

Exchange transactions between funds are reported as revenues in the seller funds and as expenditures/expenses in the purchaser funds. Flows of cash or goods from one fund to another without a requirement for repayment are reported as interfund transfers. Interfund transfers are reported as other financing sources/uses in governmental funds and after nonoperating revenues/expenses in proprietary funds. Repayments from funds responsible for particular expenditures/expenses to the funds that initially paid for them are not presented on the financial statements.

**T. Reservations of Fund Balance**

Reservations of fund balance indicate that a portion of the balance is not available for expenditure or is legally segregated for a specific future use. Balances are reserved for inventories of materials and supplies, prepaid items, loans receivable, debt service and encumbered amounts that are not accrued at year end in the governmental funds.

**MIAMI COUNTY, OHIO**

---

***Notes to the Basic Financial Statements  
For the Year Ended December 31, 2004***

---

**NOTE 1 - SUMMARY OF SIGNIFICANT ACCOUNTING POLICIES (Continued)**

**U. Net Assets**

Net assets represent the difference between assets and liabilities. Net assets invested in capital assets, net of related debt consists of capital assets, net of accumulated depreciation, reduced by the outstanding balances of any borrowings used for the acquisition, construction of improvement of those assets. Net assets are reported as restricted when there are limitations imposed on their use either through the enabling legislation adopted by the County or through external restrictions imposed by creditors, grantors or laws or regulations of other governments. Net Assets restricted for Other Purposes include programs for street and highway improvements, federal grants for public safety and human services and mandatory fines for various court programs.

The County applies restricted resources when an expense is incurred for purposes for which both restricted and unrestricted net assets are available.

**NOTE 2 – RECONCILIATION OF GOVERNMENT-WIDE AND FUND FINANCIAL STATEMENTS**

**A. Explanation of certain differences between the governmental fund balance sheet and the government-wide statement of net assets**

The governmental fund balance sheet includes a reconciliation between fund balance – total governmental funds and net assets of governmental funds as reported in the government-wide statement of net assets. The following is a detailed listing of those reconciling items that are net adjustments or a combination of several transactions:

*Other long-term assets not available to pay for current-period expenditures:*

Shared Revenues	\$15,057,266
Interest Revenue	132,501
Delinquent Tax Revenues	799,053
Loan Revenue	584,380
	<u>\$16,573,200</u>

*Long-Term liabilities not reported in the funds:*

General Obligation Bonds Payable	(\$7,050,000)
Superfund Site Liability	(2,914,659)
Capital Leases Payable	(99,379)
Accrued Interest on Long-Term Debt	(27,680)
Compensated Absences Payable	(2,504,255)
	<u>(\$12,595,973)</u>

**MIAMI COUNTY, OHIO**

---

***Notes to the Basic Financial Statements  
For the Year Ended December 31, 2004***

---

**NOTE 2 – RECONCILIATION OF GOVERNMENT-WIDE AND FUND FINANCIAL STATEMENTS (Continued)**

**B. Explanation of certain differences between the governmental fund statement of revenues, expenditures, and changes in fund balances and the government-wide statement of activities**

The governmental fund statement of revenues, expenditures, and changes in fund balances includes a reconciliation between net changes in fund balances – total governmental funds and changes in net assets of governmental activities as reported in the government – wide statement of activities. The following is a detailed listing of those reconciling items that are net adjustments or a combination of several transactions:

*Amount by which capital outlay exceeded depreciation in the current period:*

Capital Outlay	\$3,391,490
Depreciation Expense	(2,954,793)
	<u>\$436,697</u>

*Governmental revenues not reported in the funds:*

Increase in Shared Revenue	\$4,685,333
Increase in Delinquent Tax Revenue	215,881
Increase in Interest Revenue	2,865
Increase in Loan Revenue	186,611
	<u>\$5,090,690</u>

*Net amount of long-term debt issuance and bond and lease principal payments:*

General Obligation Bond Principal Payments	\$510,000
Superfund Site Liability Payment	275,109
Capital Lease Payments	53,336
	<u>\$838,445</u>

*Expenses not requiring the use of current financial resources:*

Increase in Compensated Absences Payable	(\$102,813)
Increase in supplies inventory	19,459
	<u>(\$83,354)</u>

**NOTE 3 – PRIOR PERIOD ADJUSTMENT**

During the year ended December 31, 2004, the County discovered an error in the balance of the Superfund Site Liability. The correction resulted in the restatement of the net assets at December 31, 2003 for the governmental activities. The balance of the Long Term Liabilities – Due in More Than One Year was increased by \$3,041,845 and the balance of Net Assets – Restricted for Other Purposes decreased by the same amount.

***Notes to the Basic Financial Statements  
For the Year Ended December 31, 2004***

---

**NOTE 4 - CASH, CASH EQUIVALENTS AND INVESTMENTS**

The County Treasurer combines a majority of cash resources of the individual funds to form a pool of cash and investments. Each fund type's portion of this pool is displayed on the combined balance sheet as "Cash and Cash Equivalents." Except for nonparticipating investment contracts, investments are reported at fair value, which is based on quoted market prices. Nonparticipating investment contracts such as repurchase agreements and nonnegotiable certificates of deposit are reported at cost. Ohio law requires the classification of funds held by the County into three categories.

Category 1 consists of "active" funds - those funds required to be kept in a "cash" or "cash equivalent" status for immediate use by the County. Such funds must be maintained either as cash in the County treasury or in depository accounts payable or withdrawable on demand, including negotiable order of withdrawal (NOW) accounts.

Category 2 consists of "inactive" funds - those funds not required for use within the current five year period of designation of depositories. Inactive funds may be deposited or invested only as certificates of deposit maturing not later than the end of the current period of designation of depositories.

Category 3 consists of "interim" funds - those funds which are not needed for immediate use but which will be needed before the end of the current period of designation of depositories. Interim funds may be invested or deposited in the following securities:

- United States treasury notes, bills, bonds, or any other obligation or security issued by the United States treasury or any other obligation guaranteed as to principal or interest by the United States;
- Bonds, notes, debentures, or any other obligations or securities issued by any federal government agency or instrumentality, including but not limited to, the federal national mortgage association, federal home loan bank, federal farm credit bank, federal home loan mortgage corporation, government national mortgage association, and student loan marketing association. All federal agency securities shall be direct issuances of federal government agencies or instrumentalities;
- Written repurchase agreements in the securities listed above provided that the market value of the securities subject to the repurchase agreement must exceed the principal value of the agreement by at least two percent and be marked to market daily, and that the term of the agreement must not exceed thirty days;
- Interim deposits in eligible institutions applying for interim funds;
- Bonds and other obligations of the State of Ohio;
- No-load money market mutual funds consisting exclusively of obligations described in the first two bullets of this section and repurchase agreements secured by such obligations, provided that investments in securities described in this division are made only through eligible institutions, and
- The State Treasury Asset Reserve of Ohio (STAR Ohio).



**MIAMI COUNTY, OHIO**

---

***Notes to the Basic Financial Statements  
For the Year Ended December 31, 2004***

---

**NOTE 4 - CASH, CASH EQUIVALENTS AND INVESTMENTS (Continued)**

- Commercial paper notes issued by any corporation for profit that is incorporated under the laws of the United States or any state pursuant to specifications within the Ohio Revised Code.

Ohio law requires that deposits be placed in eligible banks or savings and loan associations located in Ohio. Any public depository in which the County places deposits must pledge as collateral eligible securities of aggregate market value equal to the excess of deposits not insured by the Federal Deposit Insurance Corporation (FDIC). The securities pledged as collateral are pledged to a pool for each individual financial institution in amounts equal to at least 105% of the carrying value of all public deposits held by each institution. Obligations that may be pledged as collateral are limited to obligations of the United States and its agencies and obligations of any state, county, municipal corporation or other legally constituted authority of any other state or any instrumentality of such county, municipal corporation or other authority. Based upon criteria described in GASB Statement No. 3 "*Deposits With Financial Institutions, Investments (including Repurchase Agreements) and Reverse Repurchase Agreements,*" collateral held in single financial collateral pools with securities being held by the pledging financial institutions' agent in the pool's name are classified as Category 3.

The Governmental Accounting Standards Board has established risk categories for deposits and investments as follows:

*Deposits:*

- Category 1 Insured or collateralized with securities held by the County or by its agent in the County's name.
- Category 2 Collateralized with securities held by the pledging financial institution's trust department or agent in the County's name.
- Category 3 Uninsured and uncollateralized.

*Investments:*

- Category 1 Insured or registered, or securities held by the County or its agent in the County's name.
- Category 2 Uninsured and unregistered, with securities held by the counterparty's trust department or agent in the County's name.
- Category 3 Uninsured and unregistered, with securities held by the counterparty or by its trust department or agent but not in the County's name.

**MIAMI COUNTY, OHIO**

---

**Notes to the Basic Financial Statements  
For the Year Ended December 31, 2004**

---

**NOTE 4 - CASH, CASH EQUIVALENTS AND INVESTMENTS (Continued)**

**A. Deposits**

At year end, the carrying amount of the County's (primary government) deposits was \$29,782,733 and the bank balance was \$30,944,291. Federal depository insurance covered \$700,000 of the bank balance, and all remaining deposits were classified as Category 3. In accordance with Ohio Revised Code, the remaining balance was covered by pooled collateral. Although the State statutory requirement for the deposit of money had been followed, non-compliance with federal requirements could potentially subject the County to a successful claim by the FDIC.

At year end, the carrying amount of Riverside Training Industries' (component unit) deposits was \$227,270 and the bank balance was \$227,170. Federal depository insurance covered \$100,000 of the bank balance, and all the remaining deposits were classified as Category 3.

**B. Investments**

The County's (primary government) investments are detailed below and categorized to give an indication of the level of risk assumed as of year end.

	<u>Category 1</u>	<u>Fair Value</u>
<u>Categorized Investments</u>		
U.S. Government Securities	\$15,619,263	\$15,619,263
<u>Non-Categorized Investments</u>		
STAR Ohio	N/A	8,834,059
Total Investments	<u>\$15,619,263</u>	<u>\$24,453,322</u>

Riverside Training Industries' (component unit) investments are detailed below and categorized to give an indication of the level of risk assumed as of year end.

	<u>Category 3</u>	<u>Fair Value</u>
<u>Categorized Investments</u>		
Corporate Stocks & Bonds	\$668,594	\$668,594
U.S. Government Securities	131,661	131,661
Total Categorized	800,255	800,255
<u>Non-Categorized Investments</u>		
Mutual Funds	N/A	13,160
Total Investments	<u>\$800,255</u>	<u>\$813,415</u>

**MIAMI COUNTY, OHIO**

---

***Notes to the Basic Financial Statements  
For the Year Ended December 31, 2004***

---

**NOTE 4 - CASH, CASH EQUIVALENTS AND INVESTMENTS (Continued)**

**C. Reconciliation of Cash, Cash Equivalents and Investments**

The classification of cash, cash equivalents and investments on the financial statements is based on criteria set forth in GASB Statement No. 9. Highly liquid investments with an original maturity of three months or less are treated as cash equivalents. The classification of cash and cash equivalents (deposits) for purposes of this note are based on criteria set forth in GASB Statement No. 3.

A reconciliation between classifications of cash and investments on the statement of net assets and the classifications per items A and B of this note are as follows:

	<u>Cash and Cash Equivalents</u>	<u>Investments</u>
Per Statement of Net Assets	\$22,616,792	\$31,619,263
Certificates of Deposit (with maturities of more than 3 months)	16,000,000	(16,000,000)
Investments:		
STAR Ohio	<u>(8,834,059)</u>	<u>8,834,059</u>
Per GASB Statement No. 3	<u>\$29,782,733</u>	<u>\$24,453,322</u>

A reconciliation between classifications of cash and investments for the component unit on the statement of net assets and classifications per items A and B of this note are as follows:

	<u>Cash and Cash Equivalents</u>	<u>Investments</u>
Per Statement of Net Assets	<u>\$227,270</u>	<u>\$813,415</u>
Per GASB Statement No. 3	<u>\$227,270</u>	<u>\$813,415</u>

***Notes to the Basic Financial Statements  
For the Year Ended December 31, 2004***

---

**NOTE 5- TAXES**

**A. Property Taxes**

Property taxes include amounts levied against all real estate and public utility property, and tangible personal property located in the County and used in business. Real property taxes (other than public utility) collected during 2004 were levied after October 1, 2003 on assessed values as of January 1, 2003, the lien date. Assessed values were established by the county auditor at 35 percent of appraised market value. All property must be reappraised every six years and equalization adjustments made in the third year following reappraisal. The last revaluation was completed in 2001. Real property taxes are payable annually or semi-annually. The first payment is due February 14; the remainder payable by July 20.

Taxes collected from tangible personal property (other than public utility) in one calendar year are levied in the prior calendar year on assessed values during and at the close of the most recent fiscal year of the taxpayer that ended on or before March 31 of that calendar year, and at the tax rates determined in the preceding year.

Tangible personal property used in business (except for public utilities) is currently assessed for ad valorem taxation purposes at 25 percent of its true value. Amounts paid by multi-county taxpayers are due September 20 of the year assessed. Single county taxpayers may pay annually or semi-annually: the first payment is due April 30; the remainder payable by September 20.

Public utility real and tangible personal property taxes collected in one calendar year are levied in the preceding calendar year on assessed values determined as of December 31 of the second year preceding the tax collection year, the lien date. Certain public utility tangible personal property is currently assessed at 100 percent of its true value. Public utility property taxes are payable on the same dates as real property described previously.

The County Treasurer collects property taxes on behalf of all taxing districts in the County. The County Auditor periodically distributes to the taxing districts their portion of the taxes collected in June and December for taxes payable in the first and second halves of the year, respectively.

The full tax rate to the County for the year ended December 31, 2004, was \$9.11 per \$1,000 of assessed value. The assessed value upon which the 2005 tax receivable was based was \$2,118,359,500. This amount constitutes \$1,773,597,460 in real property assessed value, \$63,431,660 in public utility assessed value and \$281,330,380 in tangible personal property assessed value.

Ohio law prohibits taxation of property from all taxing authorities in excess of 1% of assessed value without a vote of the people. Under current procedures, the County's share is .911% (9.11 mills) of assessed value.

**MIAMI COUNTY, OHIO**

---

***Notes to the Basic Financial Statements  
For the Year Ended December 31, 2004***

---

**NOTE 5 – TAXES (Continued)**

**B. Other Taxes**

In addition to property taxes, certain other taxes are recognized as intergovernmental revenue by the County. These taxes include state shared taxes, gasoline taxes, inheritance taxes and miscellaneous other taxes which have varying lien, levy and collection dates.

**NOTE 6 - RECEIVABLES**

Receivables at December 31, 2004, consisted of taxes, accounts receivable, intergovernmental receivables arising from shared revenues, interest, loans and interfund receivables. All receivables are considered collectible in full.

**NOTE 7 - INTERFUND RECEIVABLES AND PAYABLES**

Interfund balances are expected to be repaid within one year or less. The following balances at December 31, 2004 represent interfund loans receivable and payable:

	<u>Interfund Loans</u>	
	<u>Receivables</u>	<u>Payables</u>
Governmental Funds:		
General Fund	\$15,468	\$0
Other Governmental Funds	0	15,468
Total Governmental Funds	<u>15,468</u>	<u>15,468</u>
Total Interfund Loans	<u>\$15,468</u>	<u>\$15,468</u>

Interfund loans allow some funds to operate and pay vendors timely, while awaiting anticipated revenue. Loans are often used as a means of short-term financing and a solution to providing cash flows related to reimbursable grants.

This space intentionally left blank.

**MIAMI COUNTY, OHIO**

---

***Notes to the Basic Financial Statements  
For the Year Ended December 31, 2004***

---

**NOTE 7 - INTERFUND RECEIVABLES AND PAYABLES (Continued)**

The following balances at December 31, 2004, represent due from/to other funds:

	<u>Due From Other Funds</u>	<u>Due To Other Funds</u>
Governmental Funds:		
General Fund	\$68,684	\$24,938
Motor Vehicle and Gasoline Tax	17,099	1,199
Job and Family Services	56,373	66,824
Other Governmental Funds	74,098	155,329
Total Governmental Funds	<u>216,254</u>	<u>248,290</u>
Enterprise Funds:		
Water	3,810	0
Sewer	30,247	577
Transfer Station	948	2,392
Total Enterprise Funds	<u>35,005</u>	<u>2,969</u>
Total Interfund Receivables and Payables	<u><u>\$251,259</u></u>	<u><u>\$251,259</u></u>

Due from/to Other Funds account for amounts due between different funds for internal billings such as postage, telephone, vehicle maintenance, gasoline, drug testing and unemployment charge-backs.

**NOTE 8 - TRANSFERS**

The following balances at December 31, 2004 represent transfers in and transfers out:

<u>Fund</u>	<u>Transfer In</u>	<u>Transfer Out</u>
Governmental Funds:		
General Fund	\$94,931	\$502,123
Job and Family Services Fund	0	186,174
Other Governmental Funds	993,646	400,280
Total Transfers	<u><u>\$1,088,577</u></u>	<u><u>\$1,088,577</u></u>

Transfers are used to move revenues from the fund that statute or budget requires to collect them to the fund that statute or budget requires to expend them; to segregate money for anticipated capital projects; to provide additional resources for current operations or debt service; and to return money to the fund from which it was originally provided once a project is completed.

**MIAMI COUNTY, OHIO**

**Notes to the Basic Financial Statements  
For the Year Ended December 31, 2004**

**NOTE 9 - CAPITAL ASSETS**

**A. Governmental Activities Capital Assets**

Summary by category of changes in governmental activities capital assets at December 31, 2004:

**Historical Cost:**

Class	December 31, 2003	Additions	Deletions	December 31, 2004
<b>Non-Depreciable Capital Assets:</b>				
Land	\$5,492,186	\$57,216	\$0	\$5,549,402
Construction in Progress	10,323,593	161,199	(9,789,535)	695,257
Total Non-Depreciable Capital Assets	<u>15,815,779</u>	<u>218,415</u>	<u>(9,789,535)</u>	<u>6,244,659</u>
<b>Depreciable Capital Assets:</b>				
Buildings	26,828,483	8,456,682	0	35,285,165
Improvements Other Than Buildings	237,243	19,148	0	256,391
Machinery and Equipment	18,093,940	2,693,333	(308,310)	20,478,963
Infrastructure	59,245,921	1,793,447	(15,706)	61,023,662
Total Depreciable Capital Assets	<u>104,405,587</u>	<u>12,962,610</u>	<u>(324,016)</u>	<u>117,044,181</u>
Total Cost	<u>\$120,221,366</u>	<u>\$13,181,025</u>	<u>(\$10,113,551)</u>	<u>\$123,288,840</u>

**Accumulated Depreciation:**

Class	December 31, 2003	Additions	Deletions	December 31, 2004
Buildings	(\$4,885,732)	(\$513,644)	\$0	(\$5,399,376)
Improvements Other Than Buildings	(125,690)	(11,768)	0	(137,458)
Machinery and Equipment	(12,505,343)	(1,430,081)	268,751	(13,666,673)
Infrastructure	(23,295,516)	(999,300)	9,031	(24,285,785)
Total Depreciation	<u>(\$40,812,281)</u>	<u>(\$2,954,793) *</u>	<u>\$277,782</u>	<u>(\$43,489,292)</u>
<b>Net Value:</b>	<u>\$79,409,085</u>			<u>\$79,799,548</u>

\* Depreciation expenses were charged to governmental functions as follows:

Public Safety	\$667,877
Health	150,299
Human Services	64,772
Public Works	1,324,937
General Government	746,908
Total Depreciation Expense	<u>\$2,954,793</u>

**MIAMI COUNTY, OHIO**

---

**Notes to the Basic Financial Statements  
For the Year Ended December 31, 2004**

---

**NOTE 9 - CAPITAL ASSETS (Continued)**

**B. Business-Type Activities Capital Assets**

Summary by Category at December 31, 2004:

**Historical Cost:**

Class	December 31, 2003	Additions	Deletions	December 31, 2004
<b>Non-Depreciable Capital Assets:</b>				
Land	\$90,000	\$0	\$0	\$90,000
Construction in Progress	438,818	2,061,654	(438,817)	2,061,655
Total Non-Depreciable Capital Assets	528,818	2,061,654	(438,817)	2,151,655
<b>Depreciable Capital Assets:</b>				
Buildings	2,479,272	7,700	0	2,486,972
Improvements Other Than Buildings	11,967,925	825,247	0	12,793,172
Machinery and Equipment	1,364,988	37,364	0	1,402,352
Total Depreciable Capital Assets	15,812,185	870,311	0	16,682,496
Total Cost	\$16,341,003	\$2,931,965	(\$438,817)	\$18,834,151
<b>Accumulated Depreciation:</b>				
Class	December 31, 2003	Additions	Deletions	December 31, 2004
Buildings	(\$229,958)	(\$41,965)	\$0	(\$271,923)
Improvements Other Than Buildings	(3,857,652)	(273,097)	0	(4,130,749)
Machinery and Equipment	(723,927)	(93,907)	0	(817,834)
Total Depreciation	(\$4,811,537)	(\$408,969)	\$0	(\$5,220,506)
<b>Net Value:</b>	\$11,529,466			\$13,613,645

**NOTE 10 - DEFINED BENEFIT PENSION PLANS**

All of the County's employees participate in one of two separate retirement systems which are cost-sharing multiple employer defined benefit pension plans.

**A. Ohio Public Employees Retirement System (the "OPERS")**

The following information was provided by the OPERS to assist the County in complying with GASB Statement No. 27, "Accounting for Pensions by State and Local Government Employers."



***Notes to the Basic Financial Statements  
For the Year Ended December 31, 2004***

---

**NOTE 10 – DEFINED BENEFIT PENSION PLANS (Continued)**

**A. Ohio Public Employees Retirement System (the “OPERS”) (Continued)**

All employees of the County, except teachers at the Mental Retardation and Developmental Disabilities Board, the Miami County Youth Center and the West Central Rehabilitation Center, participate in one of the three pension plans administered by the Ohio PERS: the Traditional Pension Plan (TP), the Member-Directed Plan (MD), and the Combined Plan (CO). The TP Plan is a cost-sharing multiple employer defined benefit pension plan. The MD Plan is a defined contribution plan in which the member invests both member and employer contributions (employer contributions vest over five years at 20% per year). Under the MD Plan members accumulate retirement assets equal to the value of member and (vested) employer contributions plus any investment earnings thereon. The CO Plan is a cost-sharing multiple-employer defined benefit pension plan. Under the CO Plan employer contributions are invested by the retirement system to provide a formula retirement benefit similar in nature to the TP Plan. Member contributions, the investment of which is self-directed by the members, accumulate retirement assets in a manner similar to the MD Plan..

The Ohio PERS provides retirement, disability, survivor and death benefits and annual cost-of-living adjustments to members of the TP Plan and CO Plan. Members of the MD Plan do not qualify for ancillary benefits. Chapter 145 of the Ohio Revised Code provides statutory authority to establish and amend benefits. The Ohio Public Employees Retirement System issues a stand-alone financial report that includes financial statements and required supplementary information for the Ohio PERS. Interested parties may obtain a copy by making a written request to 277 East Town Street, Columbus, Ohio 43215-4642 or by calling (614) 222-6705 or 1-800-222-7377.

The Ohio Revised Code provides statutory authority for employee and employer contributions. For 2004, employee and employer contribution rates were consistent across all three plans (TP, MD and CO). The employee contribution rate for employees other than law enforcement is 8.5%. Law enforcement officers in the County Sheriff’s department contribute 10.10% of covered salary. The 2004 employer contribution rate for local government employer units was 13.55% of covered payroll, 9.55% to fund the pension and 4.0% to fund health care. For law enforcement, the employer rate was 16.7% of covered payroll, 12.70% to fund the pension fund and 4.0% to fund health care. The contribution requirements of plan members and the County are established and may be amended by the Public Employees Retirement Board. The County’s contribution to the OPERS for the years ending December 31, 2004, 2003, and 2002 were \$3,772,630, \$3,587,943, and \$3,433,097 respectively, for employees of the County and \$423,450, \$427,698, and \$396,134 respectively, for law enforcement officers, which were equal to the required contributions for each year.

The OPERS provides postemployment health care benefits to age and service retirants with ten or more years of qualifying Ohio service credit. Health care coverage for disability recipients and primary survivor recipients is also available. The health care coverage provided by the OPERS is considered an Other Postemployment Benefit (OPEB) as described in GASB Statement No. 12. A portion of each employer's contribution to the OPERS is set aside for the funding of post

***Notes to the Basic Financial Statements  
For the Year Ended December 31, 2004***

---

**NOTE 10 – DEFINED BENEFIT PENSION PLANS (Continued)**

**A. Ohio Public Employees Retirement System (the “OPERS”) (Continued)**

retirement health care. The Ohio Revised Code provides statutory authority requiring public employers to fund postemployment health care through their contributions to the OPERS. The portion of the 2004 employer contribution rate (identified above) that was used to fund health care for the year 2004 was 4.0% of covered payroll which amounted to \$1,113,692 for employees other than law enforcement and \$101,425 for law enforcement employees.

The significant actuarial assumptions and calculations relating to postemployment health care benefits were based on the OPERS latest actuarial review performed as of December 31, 2003. An entry age normal actuarial cost method of valuation is used in determining the present value of OPEB. The difference between assumed and actual experience (actuarial gains and losses) becomes part of unfunded actuarial accrued liability. All investments are carried at market value. For actuarial valuation purposes, a smoothed market approach is used. Under this approach assets are adjusted annually to reflect 25% of unrealized market appreciation or depreciation on investment assets. The investment assumption rate for 2003 was 8.0%. An annual increase of 4.0% compounded annually, is the base portion of the individual pay increase assumption. This assumes no change in the number of active employees. Additionally, annual pay increases, over and above the 4.0% base increase, were assumed to range from 0.50% to 6.3%. Health care costs were assumed to increase 4.0% annually.

Benefits are advanced-funded on an actuarially determined basis. The number of active contributing participants was 369,885. The actuarial value of the OPERS net assets available for OPEB at December 31, 2003 is \$10.5 billion. The actuarially accrued liability and the unfunded actuarial accrued liability, based on the actuarial cost method used, were \$26.9 billion and \$16.4 billion, respectively.

**B. State Teachers Retirement System of Ohio (STRS of Ohio)**

The teachers who work for the Mental Retardation and Developmental Disabilities Board, the Miami County Youth Center and the West Central Rehabilitation Center, participate in the State Teachers Retirement System of Ohio (the "STRS"), a cost-sharing multiple employer defined benefit pension plan.

The STRS of Ohio provides retirement and disability benefits, annual cost-of-living adjustments and death benefits to plan members and beneficiaries. Benefits are established by Chapter 3307 of the Ohio Revised Code. The STRS of Ohio issues a stand-alone financial report that includes financial statements and required supplementary information for the STRS of Ohio. Interested parties may obtain a copy by making a written request to STRS Ohio, 275 E. Broad Street, Columbus, Ohio 43215-3371 or by calling (614) 227-4090, or by visiting the STRS Ohio Web site at [www.strsoh.org](http://www.strsoh.org).

***Notes to the Basic Financial Statements  
For the Year Ended December 31, 2004***

---

**NOTE 10 – DEFINED BENEFIT PENSION PLANS (Continued)**

**B. State Teachers Retirement System of Ohio (STRS of Ohio) (Continued)**

New members have a choice of three retirement plans, a Defined Benefit (DB) Plan, a Defined Contribution (DC) Plan and a Combined Plan. The DB plan offers an annual retirement allowance based on final average salary times a percentage that varies based on years of service, or an allowance based on member contributions and earned interest matched by STRS Ohio funds times an actuarially determined annuity factor. The DC Plan allows members to place all their member contributions and employer contributions equal to 10.5% of earned compensation into an investment account. Investment decisions are made by the member. A member is eligible to receive a retirement benefit at age 50 and termination of employment. The Combined Plan offers features of both the DC Plan and the DB Plan. In the Combined Plan, member contributions are invested by the member, and employer contributions are used to fund the defined benefit payment at a reduced level from the regular DB Plan. DC and Combined Plan members will transfer to the Defined Benefit Plan during their fifth year of membership unless they permanently select the DC or Combined Plan. Existing members with less than five years of service credit as of June 30, 2001, were given the option of making a one time irrevocable decision to transfer their account balances from the existing DB Plan into the DC Plan or the Combined Plan. This option expired on December 31, 2001. Benefits are established by Chapter 3307 of the Ohio Revised Code.

A DB or Combined Plan member with five or more years credited service who becomes disabled may qualify for a disability benefit. Eligible spouses and dependents of these active members who die before retirement may qualify for survivor benefits. Members in the DC Plan who become disabled are entitled only to their account balance. If a member dies before retirement benefits begin, the member's designated beneficiary is entitled to receive the member's account balance.

The Ohio Revised Code provides statutory authority for County and employee contributions of 14% and 10% through June 30, 2004. The contribution requirements of plan members and the County are established and may be amended by the State Teachers Retirement Board, upon recommendation of its consulting actuary, not to exceed statutory maximum rates of 10% for members and 14% for employers. The County's contributions to the STRS of Ohio for the years ending December 31, 2004, 2003 and 2002 were \$66,962, \$74,070, and \$79,006 respectively, which were equal to the required contributions for each year.

STRS provides postemployment health care benefits to retirees and their dependents. Coverage includes hospitalization, physicians' fees, prescription drugs, and partial reimbursement of monthly Medicare premiums. All benefit recipients and sponsored dependents are eligible for health care coverage. Pursuant to the Revised Code, the State Teachers Retirement Board has discretionary authority over how much, if any, of the health care cost will be absorbed by STRS. All benefit recipients are required to pay a portion of the health care cost in the form of a monthly premium.

**MIAMI COUNTY, OHIO**

---

**Notes to the Basic Financial Statements  
For the Year Ended December 31, 2004**

---

**NOTE 10 – DEFINED BENEFIT PENSION PLANS (Continued)**

**B. State Teachers Retirement System of Ohio (STRS of Ohio) (Continued)**

Benefits are funded on a pay-as-you-go basis through an allocation of employer contributions to a health care reserve fund equal to 1% of covered payroll for 2004. The balance of the Health Care Reserve Fund was \$3.1 billion at June 30, 2004. For the fiscal year ended June 30, 2004, the net health care costs paid by STRS were \$268,739,000. There were 111,853 eligible benefit recipients.

**NOTE 11 - COMPENSATED ABSENCES**

The costs of vacation, sick leave, and compensatory time benefits are recorded as they are earned. Employees earn sick leave at a rate of 1.25 days per month of work completed. Accumulated vacation is based upon length of service and varies within each department of the County. Upon retirement, and in certain instances, termination, an individual will be compensated for their accumulated sick leave at a maximum rate of 25% of the balance not to exceed thirty days. Additionally, County employees receive compensatory time equal to 1.5 times the hourly rate for any time worked in excess of forty hours per week.

At December 31, 2004, the County's accumulated, unpaid compensated absences amounted to \$2,601,093. Of this amount, \$2,504,255 is recorded as Governmental Activities on the Entity Wide Statement of Net Assets (\$1,477,396 is reported as due within one year), \$96,838 is recorded as Business-type activities (\$50,809 is reported as due within one year).

**NOTE 12 - NOTES PAYABLE**

The Ohio Revised Code provides that notes including renewal notes issued in anticipation of the issuance of general obligation bonds may be issued and outstanding from time to time up to a maximum period of 20 years from the date of issuance of the original notes. Bond anticipation notes may be retired at maturity from the proceeds of the sale of renewal notes or of the bonds anticipated by the notes, or from available funds of the County or a combination of these sources. The County is retiring its notes by the issuance of one year renewal notes with a portion of the principal being retired in accordance with the above provisions.

	Maturity Date	Balance January 1, 2004	Additions	(Reductions)	Balance December 31, 2004
Enterprise Funds Notes Payable:					
2.04% Water System	7/13/2005	\$0	\$817,500	\$0	\$817,500
2.04% Sewer System	7/13/2005	0	1,987,500	0	1,987,500
Total Enterprise Notes Payable		\$0	\$2,805,000	\$0	\$2,805,000

**MIAMI COUNTY, OHIO**

**Notes to the Basic Financial Statements  
For the Year Ended December 31, 2004**

**NOTE 13 - LONG-TERM LIABILITIES**

Long-term debt and other long-term obligations of the County at December 31, 2004 were as follows:

	Interest Rate	Maturity Date	Balance January 1, 2004	Additions	Retired	Balance December 31, 2004	Amounts Due Within One Year
<b>Governmental Activities:</b>							
<b>General Obligation Bonds:</b>							
1997 Human Service Building Bonds	4.20 - 4.88%	2007	\$360,000	\$0	(\$90,000)	\$270,000	\$90,000
1997 Human Service Improvement Bonds	4.20 - 4.88%	2007	115,000	0	(30,000)	85,000	30,000
1997 Juvenile Detention Center Bonds	4.20 - 4.88%	2010	1,360,000	0	(170,000)	1,190,000	175,000
2002 Hobart Building Bonds	1.65 - 5.00%	2022	3,490,000	0	(135,000)	3,355,000	140,000
2002 Juvenile Detention Center Bonds	1.65 - 5.00%	2022	960,000	0	(35,000)	925,000	40,000
2002 Utility Administration Building Bonds	1.65 - 5.00%	2022	785,000	0	(30,000)	755,000	30,000
2002 Human Service Building Bonds	1.65 - 5.00%	2022	490,000	0	(20,000)	470,000	20,000
<b>Total General Obligation Bonds</b>			<u>7,560,000</u>	<u>0</u>	<u>(510,000)</u>	<u>7,050,000</u>	<u>525,000</u>
Superfund Site Liability			3,189,768	0	(275,109)	2,914,659	0
Capital Leases			152,715	0	(53,336)	99,379	31,832
Compensated Absences			2,401,442	2,504,255	(2,401,442)	2,504,255	1,477,396
<b>Total Governmental Activities Long-term Liabilities</b>			<u>\$13,303,925</u>	<u>\$2,504,255</u>	<u>(\$3,239,887)</u>	<u>\$12,568,293</u>	<u>\$2,034,228</u>
<b>Business-Type Activities:</b>							
<b>General Obligation Bonds:</b>							
1997 Camp Troy Water Bonds	4.20 - 4.88%	2017	\$570,972	\$0	(\$30,923)	\$540,049	\$33,132
1997 Shenandoah Sewer Bonds	4.20 - 4.88%	2017	38,516	0	(2,086)	36,430	2,235
1997 Evanston Sewer Bonds	4.20 - 4.88%	2017	412,566	0	(22,344)	390,222	23,940
1997 Deercliff Sewer Bonds	4.20 - 4.88%	2017	382,580	0	(20,720)	361,860	22,200
1997 Camp Troy Sewer Bonds	4.20 - 4.88%	2017	1,180,366	0	(63,927)	1,116,439	68,493
1997 Solid Waste Bonds	4.20 - 4.88%	2010	840,000	0	(105,000)	735,000	105,000
1997 Ash Pit Bonds	4.20 - 4.88%	2010	220,000	0	(25,000)	195,000	25,000
1997 Transfer Station Improvement Bonds	4.20 - 4.88%	2017	395,000	0	(20,000)	375,000	25,000
2002 Water Line Improvement Bonds	1.65 - 5.00%	2022	835,000	0	(30,000)	805,000	35,000
2002 County Road 25 Bonds	1.65 - 5.00%	2022	50,000	0	(2,000)	48,000	2,000
2002 Monin Sewer Bonds	1.65 - 5.00%	2022	261,000	0	(12,000)	249,000	12,000
2002 Kessler Sewer Bonds	1.65 - 5.00%	2022	39,000	0	(1,000)	38,000	1,000
<b>Total General Obligation Bonds</b>			<u>5,225,000</u>	<u>0</u>	<u>(335,000)</u>	<u>4,890,000</u>	<u>355,000</u>
<b>Ohio Public Works Commission Loans:</b>							
1995 Shenandoah Sewer Replacement	0.00%	2015	215,600	0	(19,600)	196,000	19,600
2002 Brandt Water Line	0.00%	2022	450,000	0	(25,000)	425,000	25,000
<b>Total Ohio Public Works Commission Loans</b>			<u>665,600</u>	<u>0</u>	<u>(44,600)</u>	<u>621,000</u>	<u>44,600</u>
Landfill Postclosure Care Liability			23,599	495	0	24,094	0
Compensated Absences Payable			115,404	96,838	(115,404)	96,838	50,809
<b>Total Business-Type Activities Long-term Liabilities</b>			<u>\$6,029,603</u>	<u>\$97,333</u>	<u>(\$495,004)</u>	<u>\$5,631,932</u>	<u>\$450,409</u>

**MIAMI COUNTY, OHIO**

---

***Notes to the Basic Financial Statements  
For the Year Ended December 31, 2004***

---

**NOTE 13 - LONG-TERM LIABILITIES (Continued)**

**A. Principal and Interest Requirements**

A summary of the County's future debt service requirements including principal and interest at December 31, 2004 follows:

Years	General Obligation Bonds		OPWC Loans	
	Principal	Interest	Principal	Interest
2005	\$880,000	\$521,933	\$44,600	\$0
2006	915,000	489,372	44,600	0
2007	935,000	453,897	44,600	0
2008	845,000	416,668	44,600	0
2009	890,000	382,085	44,600	0
2010-2014	3,170,000	1,418,263	223,000	0
2015-2019	2,840,000	731,895	125,000	0
2020-2022	1,465,000	147,355	50,000	0
Totals	<u>\$11,940,000</u>	<u>\$4,561,468</u>	<u>\$621,000</u>	<u>\$0</u>

**B. Defeased Debt**

In December 1997, the County defeased all of its General Obligation Bonds (\$6,675,000) through the issuance of \$8,225,000 of General Obligation Bonds for various purposes (the "1997 Bonds"). The net proceeds of the 1997 Bonds have been invested in obligations guaranteed as to both principal and interest by the United States and placed in irrevocable escrow accounts which, including interest earned, will be used to pay the principal and interest on the refunded bonds. The refunded bonds, which have an outstanding balance of \$4,430,000 at December 31, 2004 are not included in the County's outstanding debt since the County has in-substance satisfied its obligations through the advance refunding.

**C. Conduit Debt**

From time to time, the County has issued Revenue Bonds to provide financial assistance to private-sector entities for the acquisition and construction of industrial and commercial facilities deemed to be in the public interest. The bonds are secured by the property financed and are payable solely from bonds, ownership of the acquired facilities transfers to the private-sector entity served by the bond issuance. Neither the County, the State, nor any political subdivision thereof is obligated in any manner for repayment of the bonds. Accordingly, the bonds are not reported as liabilities in the accompanying financial statements.

As of December 31, 2004, there were twenty-three series of Industrial Revenue Bonds and one series of Hospital Revenue Bonds outstanding. The aggregate principal amount payable for the twenty-three series of Industrial Revenue Bonds issued prior to January 1, 1996 could not be determined; however, their original issue amounts totaled \$25,499,000. The aggregate principal amount payable for the Hospital Revenue Bonds, issued July 1, 1996, was \$51,135,000 at year end.

**MIAMI COUNTY, OHIO**

---

***Notes to the Basic Financial Statements  
For the Year Ended December 31, 2004***

---

**NOTE 14 - CAPITAL LEASES**

The County is obligated under one lease accounted for as a capital lease. The cost of the leased asset (an excavator) is accounted for in the Governmental Activities as machinery and equipment. The original cost of the asset under capital lease is \$162,000.

The following is a schedule of the future minimum lease payments under the capital lease together with the present value of the net minimum lease payments as of December 31, 2004.

Year Ending December 31,	Capital Leases
2005	\$35,808
2006	35,808
2007	35,808
Minimum Lease Payments	107,424
Less: Amount representing interest at the County's incremental borrowing rate of interest	(8,045)
Present value of minimum lease payments	<u>\$99,379</u>

**NOTE 15 - SOLID WASTE LANDFILL CLOSURE AND POSTCLOSURE CARE COSTS**

The County owned and operated an incinerator and landfill which originally opened for business in 1968. The operation was intended to process and dispose of municipal and industrial waste from communities throughout Miami County. Combustible wastes were to be incinerated and noncombustible wastes were to be landfilled. However, large quantities of combustible wastes were landfilled along with noncombustible wastes. The site stopped accepting liquid wastes in 1975 and the entire landfill operations ceased in 1978 when 100% landfill capacity was attained. A new transfer station was constructed adjacent to the former incinerator building and became operational in January of 1998.

Superfund activities began in 1984 when U.S. EPA placed the site on the National Priorities List. The initial phase of site investigations was completed in the Spring of 1989. In June of 1989, the U.S. EPA announced the final cleanup plan in a Record of Decision.

After the Record of Decision was signed the U.S. EPA began negotiations with the site's potentially responsible parties (PRPs) to perform the remedial design. In July of 1992, Miami County designed and implemented a cleanup of the ash disposal pit which included capping and covering the pit. The work was completed in September of 1992 and, as noted below, the area now serves as the parking lot for the transfer station.

***Notes to the Basic Financial Statements  
For the Year Ended December 31, 2004***

---

**NOTE 15 - SOLID WASTE LANDFILL CLOSURE AND POSTCLOSURE CARE COSTS**

(Continued)

In March 1993, the U.S. EPA signed a consent decree which committed the PRPs to designing and implementing the cleanup methods described in the 1989 Record of Decision. The PRPs initiated the process of hiring contractors who would conduct site investigations required to properly design the EPA's cleanup plan. Site clearing was begun in December of 1993 and completed in January of 1994. Following the clearing, 15 monitoring wells were installed around the perimeter of the site, two piezometers and one extraction well were installed in the liquid disposal area and probes were installed in order to properly define the southern and eastern boundary of the liquid disposal area. In 1995 the north landfill cap was constructed and accepted by the EPA. The remainder of the work listed below was completed by November 1996. Final seeding, grading and site work cleanup was completed in the spring of 1997.

*North and South Landfills*

Grade and cap both North and South Landfill with single barrier caps.

*Ash Disposal Pit and Ash Pile*

Ash wastes and contaminated soils from the ash disposal pit and ash pit were consolidated into the North Landfill.

The ash disposal pit was capped and covered and the area serves as a parking lot for the current transfer station operation.

*Liquid Disposal Area and Ground Water*

The liquid disposal area was graded and capped with a double barrier cap and HDPE liner. A soil vapor extraction system was installed to remove volatile organic vapors from the soils. The contaminated ground water is being remediated by a ground water extraction system with discharge to the Troy Sewer Treatment Plant.

The total cost of the construction to close the landfill was \$2,246,000. Operation, maintenance and site monitoring costs through the year 2015 are estimated to be \$2,914,659. The estimated costs of postclosure care are subject to changes corresponding to the effects of inflation, revision of laws and other variables. Funds to cover the cost of closure and postclosure care are derived from 2% of the county-wide 1% sales tax (.02%). The .02% of the county sales tax generated \$208,941 in revenues in 2004 leaving the fund balance in the Super Cleanup Fund at \$34,413. It is estimated that the revenue derived from the sales tax will be sufficient to cover the closure and postclosure care costs identified above.



***Notes to the Basic Financial Statements  
For the Year Ended December 31, 2004***

---

**NOTE 16 - RELATED PARTY TRANSACTIONS**

During 2004, Miami County provided facilities, certain equipment, transportation, and salaries for administration, implementation, and supervision of programs to Riverside Training Industries, Inc., (the “workshop”), a discretely presented component unit of Miami County. The workshop reported \$172,572 for such contributions, recording revenue and expenses at cost or fair value, as applicable, to the extent the contribution is related to the vocational purposes of the workshop. Additional rehabilitative services provided directly to workshop clients by Miami County amounted to \$731,042.

**NOTE 17 - CONTINGENCIES**

The County is party to a consent decree, along with other local entities, for the costs of the clean-up of the former Miami County Incinerator under the Federal Superfund Program. The County has established a special revenue fund to account for the costs of the clean-up.

Additionally, the County is party to various other legal proceedings which seek damages or injunctive relief generally incidental to its operations and pending projects. The County's management is of the opinion that the ultimate disposition of the various claims and legal proceedings will not have a material, adverse effect on the County's financial position.

**NOTE 18 - RISK MANAGEMENT**

**A. Insurance**

The County is exposed to various risks of loss related to torts; theft of, damage to and destruction of assets; errors and omissions; injuries to employees and natural disasters.

The County Risk Sharing Authority, Inc. (CORSA) is a risk sharing pool made up of fifty-three counties in Ohio. CORSA was formed as an Ohio nonprofit corporation for the purpose of establishing the CORSA Insurance/Self-Insurance Program, a group primary and excess insurance/self-insurance and risk management program. Member counties agree to jointly participate in coverage of losses and pay all contributions necessary for the specified insurance coverages provided by CORSA. These coverages include comprehensive general liability, automobile liability, certain property insurance and public officials' errors and omissions liability insurance.

**MIAMI COUNTY, OHIO**

---

***Notes to the Basic Financial Statements  
For the Year Ended December 31, 2004***

---

**NOTE 18 - RISK MANAGEMENT (Continued)**

**A. Insurance (Continued)**

Each member county has one vote on all matters requiring a vote, to be cast by a designated representative. The affairs of the Corporation are managed by an elected board of not more than nine trustees. Only county commissioners of member counties are eligible to serve on the board. No county may have more than one representative on the board at any time. Each member county's control over the budgeting and financing of CORSA is limited to its voting authority and any representation it may have on the board of trustees. CORSA has issued certificates of participation in order to provide adequate cash reserves. The certificates are secured by the member counties' obligations to make coverage payments to CORSA. The participating counties have no responsibility for the payment of certificates. The County does not have an equity interest in CORSA.

There has been no significant reduction in insurance coverages from coverages in the prior year. In addition, settled claims resulting from these risks have not exceeded commercial insurance coverages in any of the past three fiscal years.

**B. Self Insurance**

The County maintains a self-funded health insurance program (Hospitalization Fund, an internal service fund) with claims processed by Medical Mutual of Ohio on behalf of the County. As an integral part of the health insurance program, a reinsurance policy has been purchased which covers claims in excess of \$100,000 per individual per year up to a maximum of \$1,000,000 per individual per year with a \$2,500,000 lifetime maximum per individual.

All funds of the County from which employee salaries are paid participate in the health insurance program and make payments to the Hospitalization Fund based on actuarial estimates of the amounts needed to pay prior and current year claims. Total contributions to the program during the year were \$5,717,152. The claims liability of \$531,352 reported in the Hospitalization Fund at December 31, 2004 is based on the requirements of GASB Statement No. 10, "Accounting and Financial Reporting for Risk Financing and Related Insurance Issues," which requires that a liability for claims be reported if information prior to issuance of the financial statements indicates that it is probable a liability has been incurred at the date of the financial statements and the amount of the loss can be reasonably estimated.

Changes in the Hospitalization Fund's claims liability amount in fiscal years 2003 and 2004 were as follows:

<u>Fiscal Year</u>	<u>Beginning of Fiscal Year Liability</u>	<u>Current Year Claims and Changes in Estimates</u>	<u>Claims Payments</u>	<u>Balance at Fiscal Year End</u>
2003	\$593,998	\$3,453,187	(\$3,758,451)	\$288,734
2004	288,734	4,671,663	(4,429,045)	531,352

**MIAMI COUNTY, OHIO**

---

***Notes to the Basic Financial Statements  
For the Year Ended December 31, 2004***

---

**NOTE 19 – CONSTRUCTION COMMITMENTS**

As of December 31, 2004, the County had the following construction commitments outstanding:

<u>Project</u>	<u>Remaining Construction Commitment</u>	<u>Expected Date of Completion</u>
Merrimont Water and Sewer	\$297,459	7/15/2005
Wonder Way Water	85,000	12/31/2005
North County Road 25A Phase 1 Sewer	18,300	7/30/2005

**NOTE 20 - JOINTLY GOVERNED ORGANIZATION**

The Tri County Board of Alcohol, Drug and Mental Health Services (Tri County Board) is a jointly governed organization among Miami, Darke and Shelby counties. The Tri County Mental Health Board provides leadership in planning for and supporting community-based alcohol, drug addiction and mental health services in cooperation with public and private resources with emphasis on the development of prevention and early intervention programming while respecting, protecting and advocating for the rights of persons as consumers of alcohol, drug addiction and mental health services. The ability to influence operations depends on the County's representation on the Board. The Board of Trustees consists of eighteen members: four members are appointed by the Director of the Ohio Department of Mental Health, four members are appointed by the Director of the Ohio Department of Alcohol And Drug Addiction Services and the remaining ten members are appointed by the County Commissioners of Miami, Darke and Shelby counties in the same proportion as the County's population bears to the total population of the three counties combined. During 2004, the County contributed \$1,664,119 by voted levy for the operations of the organization. Miami County acts as the fiscal agent for the Tri County Board and its financial activity is included as an agency of the County. Financial information may be obtained from the County Auditor, Chris A. Peebles, 201 West Main Street, Troy, Ohio 45373-2363.



*COMBINING AND INDIVIDUAL FUND  
STATEMENTS AND SCHEDULES*

---

*THE FOLLOWING COMBINING STATEMENTS AND SCHEDULES INCLUDE  
THE MAJOR AND NONMAJOR GOVERNMENTAL FUNDS AND FIDUCIARY  
FUNDS.*



***Nonmajor Governmental Funds***

---

---

***Special Revenue Funds***

---

Special Revenue Funds are used to account for the proceeds of specific revenue sources (other than amounts relating to expendable trusts or for major capital projects) that are legally restricted to expenditures for specified purposes.

**Child Support Enforcement Agency Fund**

This fund is used to account for fees collected for the administration of support enforcement activities.

**Dog and Kennel Fund**

This fund is used to account for fees collected for defraying the cost of administering the registration program, for compensation of the county dog wardens, deputy pound keepers and staff and for the payments of animal claims.

**Shelter/Domestic Violence Fund**

This fund is used to account for monies received from grant funds and the sale of marriage licenses and is maintained for the operation of the shelter and for providing assistance to victims of crime.

**Youth Services Subsidy Fund**

This fund is used to account for grant funds that are made to assist counties in developing or expanding prevention, diversion, diagnostic, counseling, treatment and rehabilitation programs for youth.

**E-911 Emergency Operations Fund**

This fund is for the deposit of the one percent (1%) sales tax and is intended to fund the operation of the Emergency 911 program.

**Public Defender Fund**

This fund receives grant funds and monies from various municipalities for services rendered and is used to fund the operation of the County Public Defender Commission.

**Delinquent Tax Collection Fund**

This fund accounts for five percent (5%) of all certified delinquent taxes and assessments collected by the County Treasurer. These funds are used for the collection of delinquent property taxes and assessments and are appropriated one half to the County Treasurer and one half to the County Prosecuting Attorney.

(Continued)

***Special Revenue Funds***

---

**Real Estate Appraisal Fund**

This fund receives money from the settlements for appraisals and reappraisals of real estate and is used to defray the costs of the appraisals.

**Pre-Trial Services Fund**

This fund is to account for screening services for defendants entering the Criminal Justice System that will establish release alternatives to better manage jail population through the Miami County Municipal Court System.

**County Conservancy Fund**

This fund is to account for funds collected for flood control purposes. The source of funding is a .02 mill property tax, which is only collected when determined to be necessary.

**Community Based Corrections Act Grant Fund**

This fund is to account for an Intensive Supervision Probation Program through the Miami County Common Pleas Court for selected non-violent felony offenders as an alternative community sanction.

**Super Cleanup Fund**

This fund is used to account for funding from the permissive tax fund used for consulting fees, legal fees and any other expenses incurred in the cleanup of the incinerator landfill.

**Emergency Management Agency Fund**

This fund is used to further enhance emergency management activities in the areas of preparing response, litigation and recovery for Miami County.

**Enforcement and Education Fund**

This fund is used to account for state funds to develop a weekend treatment program.

**Juvenile Detention / Rehabilitation Center Fund**

This fund is to account for resources used for a new juvenile detention facility of Miami County.

**County Probation Services Fund**

This fund is to account for the collection of Municipal Court Probation fees from eligible probationers who participate in the intensive supervision program which electronically monitors their activity.

(Continued)



***Special Revenue Funds***

---

**Recycle Grant Fund**

This fund is to account for funding received from the Recycle Ohio Grant for the purpose of buying recycled products and the collection of litter by the court assigned community service clients.

**Day Reporting Program Fund**

This fund is to account for state funds and its purpose is to expand the alternatives to the courts for the supervision and rehabilitation of certain felony offenders.

**Urban Mass Transportation Fund**

This fund is used to account for state funds for a transportation program designated to low income, disabled and mentally handicapped persons.

**Community Development Block Grant Fund**

This fund is to account for grant funds obtained through the state and used to assist low income families in maintaining their property.

**Children's Services Board Fund**

This fund is to account for the County's portion of the proceeds from agricultural sales for the care and treatment of children who do not receive the proper care at home.

**Legal Research Fund**

This fund is to account for revenues from fines to be used for funding the acquisition and maintenance of computerized legal research services.

**One-Stop Shop Fund**

This fund is to account for the administration of the One-Stop Shop, a combination of deputy registrar, auto title and other related services.

**Law Enforcement Fund**

This fund is to account for monies obtained through fines distributed to the County from drug related offenses or the sale and/or seizure of contraband, and is used to subsidize the County's law enforcement efforts.

**County Recorder Equipment Fund**

To account for revenues derived from the increase in recorder fees designated for the acquisition and/or maintenance of equipment for the County Recorder.

(Continued)

***Special Revenue Funds***

---

**Court Computerization Fund**

To account for revenues from fines to be used for computers and updating court computer functions.

**D.A.R.E. Fund**

To account for the grant funds received to provide local law enforcement with monies for certified DARE officers to teach in local schools the approved DARE curriculum.

**Dispute Resolution Fund**

To account for revenues collected from fines to resolve civil disputes without court intervention.

**COPS More '96 Fund**

To account for the grant funds received to purchase a Live Scan Fingerprinting System.

**Commissary Fund**

To account for revenues received from sales to inmates, purchasing of merchandise and payments for inmate medical expenses.

**Food Services Fund**

To account for grant funds received from federal sources to provide food services to the David L. Brown Youth Center, the Juvenile Detention Center and the County Jail.

**Common Pleas Court – Special Projects Fund**

To account for revenues from court costs for the purpose of Guardian Ad Litem for indigent parents and Helping Children Succeed after Divorce Program.

**Sheriff's Juvenile Safety Trust Fund**

To account for revenues from individuals and expenditures for assisting juveniles within Miami County.

**Municipal Court Restitution Fund**

This fund is used to track court ordered restitution payments made to individuals.

**Children's Services Trust Fund**

To account for donations held in trust by the County. Expenditures are restricted by the terms of the trust to provide for the care and feeding of children.

**D.A.R.E. Trust Fund**

To account for revenues from contributions of gift and donations from individuals. Expenditures are restricted to the purchase of teaching supplies and D.A.R.E. related materials.

***Debt Service Funds***

---

Debt Service Funds are used to account for retirement of the County's general obligation and special assessment bonds other than those financed by proprietary funds.

**General Obligation Debt Fund**

To account for payment of principal and interest on debt for certain County buildings.

**Special Assessment Debt Fund**

To account for special assessments used for the payment of principal and interest on special assessment debt (with governmental commitment).

***Capital Projects Funds***

---

The Capital Projects Funds are used to account for the financial resources used for the acquisition or construction of major capital facilities other than those financed by proprietary or trust funds.

**Sewer System Improvement Fund**

To account for financial resources used to construct, repair and maintain sewers.

**Permanent Improvement Fund**

To account for the cost of various buildings, remodeling projects and for certain major purchases of capital improvements. Revenues consist of a portion of Miami County's one percent (1%) sales tax.

**Health Care Capital Improvement Fund**

To account for the financial resources from the sale of the Health Care Center.

**Emergency 911 Facility Construction Fund**

To account for financial resources used for the construction of the Emergency 911 facility.

**Ditch Construction Fund**

To account for the special assessments used for the construction of the Mohler-Joint and Pemberton #843 drainage projects.

**MIAMI COUNTY, OHIO**

***Combining Balance Sheet  
Nonmajor Governmental Funds  
December 31, 2004***

	Nonmajor Special Revenue Funds	Nonmajor Debt Service Funds	Nonmajor Capital Projects Funds	Total Nonmajor Governmental Funds
<b>Assets:</b>				
Cash and Cash Equivalents	\$ 6,239,456	\$ 89,882	\$ 3,764,825	\$ 10,094,163
Investments	3,746,599	0	392,699	4,139,298
Receivables:				
Taxes	408,460	0	0	408,460
Accounts	77,046	0	0	77,046
Intergovernmental	2,728,260	0	0	2,728,260
Interest	0	0	5,846	5,846
Loans	584,380	0	0	584,380
Due from Other Funds	74,098	0	0	74,098
<b>Total Assets</b>	<b>\$ 13,858,299</b>	<b>\$ 89,882</b>	<b>\$ 4,163,370</b>	<b>\$ 18,111,551</b>
<b>Liabilities:</b>				
Accounts Payable	\$ 713,416	\$ 0	\$ 58,162	\$ 771,578
Accrued Wages and Benefits Payable	402,667	0	0	402,667
Intergovernmental Payable	53,514	0	0	53,514
Due to Other Funds	155,329	0	0	155,329
Interfund Loans Payable	15,468	0	0	15,468
Deferred Revenue	2,234,420	0	0	2,234,420
<b>Total Liabilities</b>	<b>3,574,814</b>	<b>0</b>	<b>58,162</b>	<b>3,632,976</b>
<b>Fund Balances:</b>				
Reserved for Encumbrances	704,646	377	24,472	729,495
Reserved for Debt Service	0	89,505	0	89,505
Reserved for Loans Receivable	584,380	0	0	584,380
Undesignated/Unreserved in:				
Special Revenue Funds	8,994,459	0	0	8,994,459
Capital Projects Funds	0	0	4,080,736	4,080,736
<b>Total Fund Balances</b>	<b>10,283,485</b>	<b>89,882</b>	<b>4,105,208</b>	<b>14,478,575</b>
<b>Total Liabilities and Fund Balances</b>	<b>\$ 13,858,299</b>	<b>\$ 89,882</b>	<b>\$ 4,163,370</b>	<b>\$ 18,111,551</b>

**MIAMI COUNTY, OHIO**

***Combining Statement of Revenues, Expenditures and Changes in Fund Balance  
Nonmajor Governmental Funds  
For the Year Ended December 31, 2004***

	Nonmajor Special Revenue Funds	Nonmajor Debt Service Funds	Nonmajor Capital Projects Funds	Total Nonmajor Governmental Funds
	<u>          </u>	<u>          </u>	<u>          </u>	<u>          </u>
<b>Revenues:</b>				
Taxes	\$ 2,353,171	\$ 0	\$ 0	\$ 2,353,171
Intergovernmental Revenues	8,228,255	0	0	8,228,255
Charges for Services	7,138,961	0	15,249	7,154,210
Licenses and Permits	30	0	0	30
Investment Earnings	1,292	0	45,318	46,610
Fines and Forfeitures	144,066	0	0	144,066
All Other Revenues	155,279	583	7,462	163,324
<b>Total Revenue</b>	<u>18,021,054</u>	<u>583</u>	<u>68,029</u>	<u>18,089,666</u>
<b>Expenditures:</b>				
Current:				
Public Safety	6,515,780	0	0	6,515,780
Health	273,384	0	0	273,384
Human Services	6,485,998	0	0	6,485,998
Conservation and Recreation	47,450	0	0	47,450
Public Works	1,096,657	0	0	1,096,657
General Government	2,708,376	0	0	2,708,376
Capital Outlay	0	0	636,854	636,854
Debt Service:				
Principal Retirement	0	510,000	0	510,000
Interest and Fiscal Charges	0	309,230	0	309,230
<b>Total Expenditures</b>	<u>17,127,645</u>	<u>819,230</u>	<u>636,854</u>	<u>18,583,729</u>
Excess (Deficiency) of Revenues Over Expenditures	893,409	(818,647)	(568,825)	(494,063)
<b>Other Financing Sources (Uses):</b>				
Transfers In	0	827,646	166,000	993,646
Transfers Out	(319,931)	0	(80,349)	(400,280)
<b>Total Other Financing Sources (Uses)</b>	<u>(319,931)</u>	<u>827,646</u>	<u>85,651</u>	<u>593,366</u>
Net Change in Fund Balance	573,478	8,999	(483,174)	99,303
<b>Fund Balances at Beginning of Year</b>	<u>9,710,007</u>	<u>80,883</u>	<u>4,588,382</u>	<u>14,379,272</u>
<b>Fund Balances End of Year</b>	<u>\$ 10,283,485</u>	<u>\$ 89,882</u>	<u>\$ 4,105,208</u>	<u>\$ 14,478,575</u>

**MIAMI COUNTY, OHIO**

**Combining Balance Sheet  
Nonmajor Special Revenue Funds  
December 31, 2004**

	Child Support Enforcement Agency	Dog and Kennel	Shelter/ Domestic Violence	Youth Services Subsidy	E-911 Emergency Operations
<b>Assets:</b>					
Cash and Cash Equivalents	\$ 740,700	\$ 122,109	\$ 44,446	\$ 474,733	\$ 712,655
Investments	825,722	0	0	0	794,456
Receivables:					
Taxes	0	0	0	0	354,287
Accounts	0	1,520	1,747	0	0
Intergovernmental	31,736	0	67,749	146,808	11,625
Loans	0	0	0	0	0
Due from Other Funds	0	0	0	0	5,186
<b>Total Assets</b>	<u>\$ 1,598,158</u>	<u>\$ 123,629</u>	<u>\$ 113,942</u>	<u>\$ 621,541</u>	<u>\$ 1,878,209</u>
<b>Liabilities:</b>					
Accounts Payable	\$ 2,179	\$ 2,026	\$ 0	\$ 5,854	\$ 23,242
Accrued Wages and Benefits Payable	30,724	10,182	7,278	31,947	58,169
Intergovernmental Payable	0	1,835	14,589	9,062	0
Due to Other Funds	114,900	423	0	1,643	0
Interfund Loans Payable	0	0	0	0	0
Deferred Revenue	0	0	54,361	72,830	0
<b>Total Liabilities</b>	<u>147,803</u>	<u>14,466</u>	<u>76,228</u>	<u>121,336</u>	<u>81,411</u>
<b>Fund Balances:</b>					
Reserved for Encumbrances	8,108	2,857	630	53,684	38,152
Reserved for Loans Receivable	0	0	0	0	0
Undesignated/Unreserved	1,442,247	106,306	37,084	446,521	1,758,646
<b>Total Fund Balances</b>	<u>1,450,355</u>	<u>109,163</u>	<u>37,714</u>	<u>500,205</u>	<u>1,796,798</u>
<b>Total Liabilities and Fund Balances</b>	<u>\$ 1,598,158</u>	<u>\$ 123,629</u>	<u>\$ 113,942</u>	<u>\$ 621,541</u>	<u>\$ 1,878,209</u>

**MIAMI COUNTY, OHIO**

***Combining Balance Sheet  
Nonmajor Special Revenue Funds  
December 31, 2004***

Public Defender	Delinquent Tax Collection	Real Estate Appraisal	Pre-Trial Services	County Conservancy	Community Based Corrections Act Grant	Super Cleanup	Emergency Management Agency
\$ 204,390	\$ 167,499	\$ 398,152	\$ 15,935	\$ 87,798	\$ 41,828	\$ 39,098	\$ 92,868
0	0	443,854	0	0	0	0	0
0	0	0	0	18,744	0	35,429	0
2,865	0	0	0	0	0	0	0
28,362	0	0	44,524	3,181	43,598	0	417,079
0	0	0	0	0	0	0	0
0	0	0	0	0	0	0	0
<u>\$ 235,617</u>	<u>\$ 167,499</u>	<u>\$ 842,006</u>	<u>\$ 60,459</u>	<u>\$ 109,723</u>	<u>\$ 85,426</u>	<u>\$ 74,527</u>	<u>\$ 509,947</u>
\$ 0	\$ 0	\$ 13,788	\$ 0	\$ 0	\$ 0	\$ 12,276	\$ 0
16,994	4,523	18,506	3,591	0	3,332	0	0
0	0	0	0	0	0	0	0
0	0	0	0	0	0	27,838	0
0	0	0	9,026	0	0	0	0
0	0	0	22,262	21,925	21,799	0	410,958
<u>16,994</u>	<u>4,523</u>	<u>32,294</u>	<u>34,879</u>	<u>21,925</u>	<u>25,131</u>	<u>40,114</u>	<u>410,958</u>
4,053	150	68,391	293	0	426	628	20,483
0	0	0	0	0	0	0	0
<u>214,570</u>	<u>162,826</u>	<u>741,321</u>	<u>25,287</u>	<u>87,798</u>	<u>59,869</u>	<u>33,785</u>	<u>78,506</u>
<u>218,623</u>	<u>162,976</u>	<u>809,712</u>	<u>25,580</u>	<u>87,798</u>	<u>60,295</u>	<u>34,413</u>	<u>98,989</u>
<u>\$ 235,617</u>	<u>\$ 167,499</u>	<u>\$ 842,006</u>	<u>\$ 60,459</u>	<u>\$ 109,723</u>	<u>\$ 85,426</u>	<u>\$ 74,527</u>	<u>\$ 509,947</u>

(Continued)

**MIAMI COUNTY, OHIO**

**Combining Balance Sheet  
Nonmajor Special Revenue Funds  
December 31, 2004**

	Enforcement and Education	Juvenile Detention / Rehabilitation Center	County Probation Services	Recycle Grant	Day Reporting Program
<b>Assets:</b>					
Cash and Cash Equivalents	\$ 35,544	\$ 576,931	\$ 245,447	\$ 10,678	\$ 89
Investments	0	643,157	0	0	0
Receivables:					
Taxes	0	0	0	0	0
Accounts	535	0	1,005	0	0
Intergovernmental	0	1,078,591	19,230	11,320	0
Loans	0	0	0	0	0
Due from Other Funds	0	0	0	0	0
<b>Total Assets</b>	<b>\$ 36,079</b>	<b>\$ 2,298,679</b>	<b>\$ 265,682</b>	<b>\$ 21,998</b>	<b>\$ 89</b>
<b>Liabilities:</b>					
Accounts Payable	\$ 0	\$ 29,968	\$ 300	\$ 0	\$ 0
Accrued Wages and Benefits Payable	0	110,762	12,106	2,409	0
Intergovernmental Payable	1,724	4,384	7,413	0	0
Due to Other Funds	0	9,658	867	0	0
Interfund Loans Payable	5,299	0	1,143	0	0
Deferred Revenue	0	392,637	9,615	11,320	0
<b>Total Liabilities</b>	<b>7,023</b>	<b>547,409</b>	<b>31,444</b>	<b>13,729</b>	<b>0</b>
<b>Fund Balances:</b>					
Reserved for Encumbrances	2,565	123,925	2,266	800	0
Reserved for Loans Receivable	0	0	0	0	0
Undesignated/Unreserved	26,491	1,627,345	231,972	7,469	89
<b>Total Fund Balances</b>	<b>29,056</b>	<b>1,751,270</b>	<b>234,238</b>	<b>8,269</b>	<b>89</b>
<b>Total Liabilities and Fund Balances</b>	<b>\$ 36,079</b>	<b>\$ 2,298,679</b>	<b>\$ 265,682</b>	<b>\$ 21,998</b>	<b>\$ 89</b>



**MIAMI COUNTY, OHIO**

***Combining Balance Sheet  
Nonmajor Special Revenue Funds  
December 31, 2004***

Urban Mass Transportation	Community Development Block Grant	Children's Services Board	Legal Research	One-Stop Shop	Law Enforcement	County Recorder Equipment
\$ 7,630	\$ 298,296	\$ 298,759	\$ 29,131	\$ 466,120	\$ 52,921	\$ 164,034
0	332,536	333,052	0	0	0	0
0	0	0	0	0	0	0
0	0	0	0	31,148	0	0
0	327,100	468,609	0	640	0	0
0	584,380	0	0	0	0	0
15,225	0	53,687	0	0	0	0
<u>\$ 22,855</u>	<u>\$ 1,542,312</u>	<u>\$ 1,154,107</u>	<u>\$ 29,131</u>	<u>\$ 497,908</u>	<u>\$ 52,921</u>	<u>\$ 164,034</u>
\$ 0	\$ 384,560	\$ 208,642	\$ 454	\$ 363	\$ 0	\$ 877
0	0	61,385	0	12,363	0	0
0	0	11,343	0	0	920	0
0	0	0	0	0	0	0
0	0	0	0	0	0	0
0	893,980	322,733	0	0	0	0
0	1,278,540	604,103	454	12,726	920	877
0	98,217	164,900	1,130	33,383	598	123
0	584,380	0	0	0	0	0
22,855	(418,825)	385,104	27,547	451,799	51,403	163,034
<u>22,855</u>	<u>263,772</u>	<u>550,004</u>	<u>28,677</u>	<u>485,182</u>	<u>52,001</u>	<u>163,157</u>
<u>\$ 22,855</u>	<u>\$ 1,542,312</u>	<u>\$ 1,154,107</u>	<u>\$ 29,131</u>	<u>\$ 497,908</u>	<u>\$ 52,921</u>	<u>\$ 164,034</u>

(Continued)

**MIAMI COUNTY, OHIO**

---

**Combining Balance Sheet  
Nonmajor Special Revenue Funds  
December 31, 2004**

---

	Court Computerization	D.A.R.E.	Dispute Resolution	COPS More '96	Commissary
<b>Assets:</b>					
Cash and Cash Equivalents	\$ 335,330	\$ 8,117	\$ 81,571	\$ 29,741	\$ 93,704
Investments	373,822	0	0	0	0
Receivables:					
Taxes	0	0	0	0	0
Accounts	19,310	0	7,733	0	0
Intergovernmental	0	0	0	0	0
Loans	0	0	0	0	0
Due from Other Funds	0	0	0	0	0
<b>Total Assets</b>	<b>\$ 728,462</b>	<b>\$ 8,117</b>	<b>\$ 89,304</b>	<b>\$ 29,741</b>	<b>\$ 93,704</b>
<b>Liabilities:</b>					
Accounts Payable	\$ 3,632	\$ 0	\$ 1,350	\$ 0	\$ 9,851
Accrued Wages and Benefits Payable	5,507	0	5,390	5,716	0
Intergovernmental Payable	0	0	0	0	688
Due to Other Funds	0	0	0	0	0
Interfund Loans Payable	0	0	0	0	0
Deferred Revenue	0	0	0	0	0
<b>Total Liabilities</b>	<b>9,139</b>	<b>0</b>	<b>6,740</b>	<b>5,716</b>	<b>10,539</b>
<b>Fund Balances:</b>					
Reserved for Encumbrances	34,943	0	4,445	0	28,451
Reserved for Loans Receivable	0	0	0	0	0
Undesignated/Unreserved	684,380	8,117	78,119	24,025	54,714
<b>Total Fund Balances</b>	<b>719,323</b>	<b>8,117</b>	<b>82,564</b>	<b>24,025</b>	<b>83,165</b>
<b>Total Liabilities and Fund Balances</b>	<b>\$ 728,462</b>	<b>\$ 8,117</b>	<b>\$ 89,304</b>	<b>\$ 29,741</b>	<b>\$ 93,704</b>

**MIAMI COUNTY, OHIO**

***Combining Balance Sheet  
Nonmajor Special Revenue Funds  
December 31, 2004***

Food Services	Common Pleas Court - Special Projects	Sheriff's Juvenile Safety Trust	Municipal Court Restitution	Children's Services Trust	D.A.R.E. Trust	Total Nonmajor Special Revenue Funds
\$ 120,975	\$ 199,174	\$ 2,920	\$ 6,013	\$ 28,137	\$ 5,983	\$ 6,239,456
0	0	0	0	0	0	3,746,599
0	0	0	0	0	0	408,460
0	11,183	0	0	0	0	77,046
28,108	0	0	0	0	0	2,728,260
0	0	0	0	0	0	584,380
0	0	0	0	0	0	74,098
<u>\$ 149,083</u>	<u>\$ 210,357</u>	<u>\$ 2,920</u>	<u>\$ 6,013</u>	<u>\$ 28,137</u>	<u>\$ 5,983</u>	<u>\$ 13,858,299</u>
\$ 4,782	\$ 6,105	\$ 0	\$ 3,167	\$ 0	\$ 0	\$ 713,416
0	1,783	0	0	0	0	402,667
356	1,200	0	0	0	0	53,514
0	0	0	0	0	0	155,329
0	0	0	0	0	0	15,468
0	0	0	0	0	0	2,234,420
<u>5,138</u>	<u>9,088</u>	<u>0</u>	<u>3,167</u>	<u>0</u>	<u>0</u>	<u>3,574,814</u>
5,198	2,182	0	3,665	0	0	704,646
0	0	0	0	0	0	584,380
138,747	199,087	2,920	(819)	28,137	5,983	8,994,459
<u>143,945</u>	<u>201,269</u>	<u>2,920</u>	<u>2,846</u>	<u>28,137</u>	<u>5,983</u>	<u>10,283,485</u>
<u>\$ 149,083</u>	<u>\$ 210,357</u>	<u>\$ 2,920</u>	<u>\$ 6,013</u>	<u>\$ 28,137</u>	<u>\$ 5,983</u>	<u>\$ 13,858,299</u>

**MIAMI COUNTY, OHIO**

***Combining Statement of Revenues, Expenditures and Changes in Fund Balance  
Nonmajor Special Revenue Funds  
For the Year Ended December 31, 2004***

	Child Support Enforcement Agency	Dog and Kennel	Shelter/ Domestic Violence	Youth Services Subsidy	E-911 Emergency Operations
<b>Revenues:</b>					
Taxes	\$ 0	\$ 0	\$ 0	\$ 0	\$ 2,089,404
Intergovernmental Revenues	854,582	0	174,529	357,320	0
Charges for Services	359,153	260,073	0	553,088	90,485
Licenses and Permits	0	0	0	0	0
Investment Earnings	0	0	0	0	0
Fines and Forfeitures	0	16,787	0	0	0
All Other Revenue	10,626	153	8,366	9,310	0
<b>Total Revenue</b>	<u>1,224,361</u>	<u>277,013</u>	<u>182,895</u>	<u>919,718</u>	<u>2,179,889</u>
<b>Expenditures:</b>					
Current:					
Public Safety	0	0	0	261,132	1,956,833
Health	0	273,384	0	0	0
Human Services	1,451,175	0	199,459	651,530	0
Conservation and Recreation	0	0	0	0	0
Public Works	0	0	0	0	0
General Government	0	0	0	0	0
<b>Total Expenditures</b>	<u>1,451,175</u>	<u>273,384</u>	<u>199,459</u>	<u>912,662</u>	<u>1,956,833</u>
Excess (Deficiency) of Revenues Over Expenditures	(226,814)	3,629	(16,564)	7,056	223,056
<b>Other Financing Sources (Uses):</b>					
Transfers Out	0	0	0	0	0
<b>Total Other Financing Sources (Uses)</b>	<u>0</u>	<u>0</u>	<u>0</u>	<u>0</u>	<u>0</u>
Net Change in Fund Balance	(226,814)	3,629	(16,564)	7,056	223,056
<b>Fund Balances at Beginning of Year</b>	<u>1,677,169</u>	<u>105,534</u>	<u>54,278</u>	<u>493,149</u>	<u>1,573,742</u>
<b>Fund Balances End of Year</b>	<u>\$ 1,450,355</u>	<u>\$ 109,163</u>	<u>\$ 37,714</u>	<u>\$ 500,205</u>	<u>\$ 1,796,798</u>

**MIAMI COUNTY, OHIO**

***Combining Statement of Revenues, Expenditures and Changes in Fund Balance  
Nonmajor Special Revenue Funds  
For the Year Ended December 31, 2004***

Public Defender	Delinquent Tax Collection	Real Estate Appraisal	Pre-Trial Services	County Conservancy	Community Based Corrections Act Grant	Super Cleanup	Emergency Management Agency
\$ 0	\$ 0	\$ 0	\$ 0	\$ 54,826	\$ 0	\$ 208,941	\$ 0
341,268	0	0	88,512	7,044	86,925	0	525,632
55,872	148,286	868,410	0	0	0	0	0
0	0	30	0	0	0	0	0
0	0	0	0	0	0	0	0
0	0	0	0	0	0	0	0
1,320	1,713	0	0	0	0	0	3,006
<u>398,460</u>	<u>149,999</u>	<u>868,440</u>	<u>88,512</u>	<u>61,870</u>	<u>86,925</u>	<u>208,941</u>	<u>528,638</u>
0	0	0	0	0	0	0	558,701
0	0	0	0	0	0	0	0
0	0	0	0	0	0	0	0
0	0	0	0	47,450	0	0	0
0	0	0	0	0	0	275,109	0
<u>390,600</u>	<u>100,854</u>	<u>589,659</u>	<u>88,488</u>	<u>0</u>	<u>89,421</u>	<u>0</u>	<u>0</u>
<u>390,600</u>	<u>100,854</u>	<u>589,659</u>	<u>88,488</u>	<u>47,450</u>	<u>89,421</u>	<u>275,109</u>	<u>558,701</u>
7,860	49,145	278,781	24	14,420	(2,496)	(66,168)	(30,063)
0	0	0	0	0	0	0	0
<u>0</u>	<u>0</u>	<u>0</u>	<u>0</u>	<u>0</u>	<u>0</u>	<u>0</u>	<u>0</u>
7,860	49,145	278,781	24	14,420	(2,496)	(66,168)	(30,063)
210,763	113,831	530,931	25,556	73,378	62,791	100,581	129,052
<u>\$ 218,623</u>	<u>\$ 162,976</u>	<u>\$ 809,712</u>	<u>\$ 25,580</u>	<u>\$ 87,798</u>	<u>\$ 60,295</u>	<u>\$ 34,413</u>	<u>\$ 98,989</u>

(Continued)

**MIAMI COUNTY, OHIO**

***Combining Statement of Revenues, Expenditures and Changes in Fund Balance  
Nonmajor Special Revenue Funds  
For the Year Ended December 31, 2004***

	Enforcement and Education	Juvenile Detention / Rehabilitation Center	County Probation Services	Recycle Grant	Day Reporting Program
<b>Revenues:</b>					
Taxes	\$ 0	\$ 0	\$ 0	\$ 0	\$ 0
Intergovernmental Revenues	7,001	1,624,451	38,599	46,195	0
Charges for Services	0	2,091,140	255,859	0	0
Licenses and Permits	0	0	0	0	0
Investment Earnings	0	0	0	0	0
Fines and Forfeitures	10,087	0	0	0	0
All Other Revenue	37	2,820	204	0	1
<b>Total Revenue</b>	<u>17,125</u>	<u>3,718,411</u>	<u>294,662</u>	<u>46,195</u>	<u>1</u>
<b>Expenditures:</b>					
Current:					
Public Safety	8,884	3,272,236	0	0	0
Health	0	0	0	0	0
Human Services	0	0	0	0	0
Conservation and Recreation	0	0	0	0	0
Public Works	0	0	0	0	0
General Government	15,905	0	363,558	65,118	0
<b>Total Expenditures</b>	<u>24,789</u>	<u>3,272,236</u>	<u>363,558</u>	<u>65,118</u>	<u>0</u>
Excess (Deficiency) of Revenues Over Expenditures	(7,664)	446,175	(68,896)	(18,923)	1
<b>Other Financing Sources (Uses):</b>					
Transfers Out	0	(225,000)	0	0	0
<b>Total Other Financing Sources (Uses)</b>	<u>0</u>	<u>(225,000)</u>	<u>0</u>	<u>0</u>	<u>0</u>
Net Change in Fund Balance	(7,664)	221,175	(68,896)	(18,923)	1
<b>Fund Balances at Beginning of Year</b>	<u>36,720</u>	<u>1,530,095</u>	<u>303,134</u>	<u>27,192</u>	<u>88</u>
<b>Fund Balances End of Year</b>	<u>\$ 29,056</u>	<u>\$ 1,751,270</u>	<u>\$ 234,238</u>	<u>\$ 8,269</u>	<u>\$ 89</u>

**MIAMI COUNTY, OHIO**

***Combining Statement of Revenues, Expenditures and Changes in Fund Balance  
Nonmajor Special Revenue Funds  
For the Year Ended December 31, 2004***

Urban Mass Transportation	Community Development Block Grant	Children's Services Board	Legal Research	One-Stop Shop	Law Enforcement	County Recorder Equipment
\$ 0	\$ 0	\$ 0	\$ 0	\$ 0	\$ 0	\$ 0
0	874,793	2,920,122	0	0	2,608	0
15,225	0	1,189,127	9,123	485,389	24,282	98,216
0	0	0	0	0	0	0
0	0	0	0	0	0	0
0	0	0	2,174	0	1,849	0
0	8,963	31,407	0	416	0	0
<u>15,225</u>	<u>883,756</u>	<u>4,140,656</u>	<u>11,297</u>	<u>485,805</u>	<u>28,739</u>	<u>98,216</u>
0	0	0	0	0	23,702	0
0	0	0	0	0	0	0
0	0	4,165,267	0	0	0	0
0	0	0	0	0	0	0
0	821,548	0	0	0	0	0
12,854	0	0	10,877	437,502	0	21,340
<u>12,854</u>	<u>821,548</u>	<u>4,165,267</u>	<u>10,877</u>	<u>437,502</u>	<u>23,702</u>	<u>21,340</u>
2,371	62,208	(24,611)	420	48,303	5,037	76,876
0	0	0	0	(94,931)	0	0
<u>0</u>	<u>0</u>	<u>0</u>	<u>0</u>	<u>(94,931)</u>	<u>0</u>	<u>0</u>
2,371	62,208	(24,611)	420	(46,628)	5,037	76,876
20,484	201,564	574,615	28,257	531,810	46,964	86,281
<u>\$ 22,855</u>	<u>\$ 263,772</u>	<u>\$ 550,004</u>	<u>\$ 28,677</u>	<u>\$ 485,182</u>	<u>\$ 52,001</u>	<u>\$ 163,157</u>

(Continued)

**MIAMI COUNTY, OHIO**

***Combining Statement of Revenues, Expenditures and Changes in Fund Balance  
Nonmajor Special Revenue Funds  
For the Year Ended December 31, 2004***

	Court Computerization	D.A.R.E.	Dispute Resolution	COPS More '96	Commissary
<b>Revenues:</b>					
Taxes	\$ 0	\$ 0	\$ 0	\$ 0	\$ 0
Intergovernmental Revenues	0	8,115	32,940	49,999	0
Charges for Services	255,575	0	0	0	226,686
Licenses and Permits	0	0	0	0	0
Investment Earnings	0	0	0	0	0
Fines and Forfeitures	0	0	113,169	0	0
All Other Revenue	154	0	0	0	173
<b>Total Revenue</b>	<u>255,729</u>	<u>8,115</u>	<u>146,109</u>	<u>49,999</u>	<u>226,859</u>
<b>Expenditures:</b>					
Current:					
Public Safety	0	13,214	0	113,338	212,761
Health	0	0	0	0	0
Human Services	0	0	0	0	0
Conservation and Recreation	0	0	0	0	0
Public Works	0	0	0	0	0
General Government	207,674	0	164,754	0	0
<b>Total Expenditures</b>	<u>207,674</u>	<u>13,214</u>	<u>164,754</u>	<u>113,338</u>	<u>212,761</u>
Excess (Deficiency) of Revenues Over Expenditures	48,055	(5,099)	(18,645)	(63,339)	14,098
<b>Other Financing Sources (Uses):</b>					
Transfers Out	0	0	0	0	0
<b>Total Other Financing Sources (Uses)</b>	<u>0</u>	<u>0</u>	<u>0</u>	<u>0</u>	<u>0</u>
Net Change in Fund Balance	48,055	(5,099)	(18,645)	(63,339)	14,098
<b>Fund Balances at Beginning of Year</b>	<u>671,268</u>	<u>13,216</u>	<u>101,209</u>	<u>87,364</u>	<u>69,067</u>
<b>Fund Balances End of Year</b>	<u>\$ 719,323</u>	<u>\$ 8,117</u>	<u>\$ 82,564</u>	<u>\$ 24,025</u>	<u>\$ 83,165</u>



**MIAMI COUNTY, OHIO**

***Combining Statement of Revenues, Expenditures and Changes in Fund Balance  
Nonmajor Special Revenue Funds  
For the Year Ended December 31, 2004***

Food Services	Common Pleas Court - Special Projects	Sheriff's Juvenile Safety Trust	Municipal Court Restitution	Children's Services Trust	D.A.R.E. Trust	Total Nonmajor Special Revenue Funds
\$ 0	\$ 0	\$ 0	\$ 0	\$ 0	\$ 0	\$ 2,353,171
187,620	0	0	0	0	0	8,228,255
0	152,972	0	0	0	0	7,138,961
0	0	0	0	0	0	30
0	0	0	0	1,292	0	1,292
0	0	0	0	0	0	144,066
0	0	0	76,010	0	600	155,279
<u>187,620</u>	<u>152,972</u>	<u>0</u>	<u>76,010</u>	<u>1,292</u>	<u>600</u>	<u>18,021,054</u>
94,979	0	0	0	0	0	6,515,780
0	0	0	0	0	0	273,384
18,567	0	0	0	0	0	6,485,998
0	0	0	0	0	0	47,450
0	0	0	0	0	0	1,096,657
0	75,095	0	74,677	0	0	2,708,376
<u>113,546</u>	<u>75,095</u>	<u>0</u>	<u>74,677</u>	<u>0</u>	<u>0</u>	<u>17,127,645</u>
74,074	77,877	0	1,333	1,292	600	893,409
0	0	0	0	0	0	(319,931)
<u>0</u>	<u>0</u>	<u>0</u>	<u>0</u>	<u>0</u>	<u>0</u>	<u>(319,931)</u>
74,074	77,877	0	1,333	1,292	600	573,478
69,871	123,392	2,920	1,513	26,845	5,383	9,710,007
<u>\$ 143,945</u>	<u>\$ 201,269</u>	<u>\$ 2,920</u>	<u>\$ 2,846</u>	<u>\$ 28,137</u>	<u>\$ 5,983</u>	<u>\$ 10,283,485</u>

**MIAMI COUNTY, OHIO**

---

**Combining Balance Sheet  
Nonmajor Debt Service Funds  
December 31, 2004**

---

	General Obligation Debt	Special Assessment Debt	Total Nonmajor Debt Service Funds
<b>Assets:</b>			
Cash and Cash Equivalents	\$ 87,153	\$ 2,729	\$ 89,882
<b>Total Assets</b>	<u>\$ 87,153</u>	<u>\$ 2,729</u>	<u>\$ 89,882</u>
<b>Liabilities:</b>			
<b>Total Liabilities</b>	<u>\$ 0</u>	<u>\$ 0</u>	<u>\$ 0</u>
<b>Fund Balances:</b>			
Reserved for Encumbrances	377	0	377
Reserved for Debt Service	86,776	2,729	89,505
<b>Total Fund Balances</b>	<u>87,153</u>	<u>2,729</u>	<u>89,882</u>
<b>Total Liabilities and Fund Balances</b>	<u>\$ 87,153</u>	<u>\$ 2,729</u>	<u>\$ 89,882</u>

**MIAMI COUNTY, OHIO**

---

***Combining Statement of Revenues, Expenditures and Changes in Fund Balance  
Nonmajor Debt Service Funds  
For the Year Ended December 31, 2004***

---

	General Obligation Debt	Special Assessment Debt	Total Nonmajor Debt Service Funds
<b>Revenues:</b>			
All Other Revenues	\$ 583	\$ 0	\$ 583
<b>Total Revenue</b>	<u>583</u>	<u>0</u>	<u>583</u>
<b>Expenditures:</b>			
Debt Service:			
Principal Retirement	510,000	0	510,000
Interest and Fiscal Charges	309,230	0	309,230
<b>Total Expenditures</b>	<u>819,230</u>	<u>0</u>	<u>819,230</u>
Excess (Deficiency) of Revenues Over Expenditures	(818,647)	0	(818,647)
<b>Other Financing Sources (Uses):</b>			
Transfers In	827,646	0	827,646
<b>Total Other Financing Sources (Uses)</b>	<u>827,646</u>	<u>0</u>	<u>827,646</u>
Net Change in Fund Balance	8,999	0	8,999
<b>Fund Balances at Beginning of Year</b>	78,154	2,729	80,883
<b>Fund Balances End of Year</b>	<u>\$ 87,153</u>	<u>\$ 2,729</u>	<u>\$ 89,882</u>

**MIAMI COUNTY, OHIO**

---

**Combining Balance Sheet  
Nonmajor Capital Projects Funds  
December 31, 2004**

---

	Sewer System Improvement	Permanent Improvement	Health Care Improvement	E-911 Facility Construction	Ditch Construction	Total Nonmajor Capital Projects Funds
<b>Assets:</b>						
Cash and Cash Equivalents	\$ 5,394	\$ 352,265	\$ 3,363,682	\$ 24,822	\$ 18,662	\$ 3,764,825
Investments	0	392,699	0	0	0	392,699
Receivables:						
Interest	0	0	5,846	0	0	5,846
<b>Total Assets</b>	<u>\$ 5,394</u>	<u>\$ 744,964</u>	<u>\$ 3,369,528</u>	<u>\$ 24,822</u>	<u>\$ 18,662</u>	<u>\$ 4,163,370</u>
<b>Liabilities:</b>						
Accounts Payable	\$ 0	\$ 58,162	\$ 0	\$ 0	\$ 0	\$ 58,162
<b>Total Liabilities</b>	<u>0</u>	<u>58,162</u>	<u>0</u>	<u>0</u>	<u>0</u>	<u>58,162</u>
<b>Fund Balances:</b>						
Reserved for Encumbrances	0	24,472	0	0	0	24,472
Undesignated/Unreserved	5,394	662,330	3,369,528	24,822	18,662	4,080,736
<b>Total Fund Balances</b>	<u>5,394</u>	<u>686,802</u>	<u>3,369,528</u>	<u>24,822</u>	<u>18,662</u>	<u>4,105,208</u>
<b>Total Liabilities and Fund Balances</b>	<u>\$ 5,394</u>	<u>\$ 744,964</u>	<u>\$ 3,369,528</u>	<u>\$ 24,822</u>	<u>\$ 18,662</u>	<u>\$ 4,163,370</u>

**MIAMI COUNTY, OHIO**

***Combining Statement of Revenues, Expenditures and Changes in Fund Balance  
Nonmajor Capital Projects Funds  
For the Year Ended December 31, 2004***

	Sewer System Improvement	Permanent Improvement	Health Care Improvement	E-911 Facility Construction	Ditch Construction	Total Nonmajor Capital Project Funds
<b>Revenues:</b>						
Charges for Services	\$ 0	\$ 15,249	\$ 0	\$ 0	\$ 0	\$ 15,249
Investment Earnings	0	0	45,318	0	0	45,318
All Other Revenues	0	77	0	0	7,385	7,462
<b>Total Revenue</b>	<u>0</u>	<u>15,326</u>	<u>45,318</u>	<u>0</u>	<u>7,385</u>	<u>68,029</u>
<b>Expenditures:</b>						
Current:						
Capital Outlay	0	633,152	0	0	3,702	636,854
<b>Total Expenditures</b>	<u>0</u>	<u>633,152</u>	<u>0</u>	<u>0</u>	<u>3,702</u>	<u>636,854</u>
Excess (Deficiency) of Revenues Over Expenditures	0	(617,826)	45,318	0	3,683	(568,825)
<b>Other Financing Sources (Uses):</b>						
Transfers In	0	166,000	0	0	0	166,000
Transfers Out	0	0	(80,349)	0	0	(80,349)
<b>Total Other Financing Sources (Uses)</b>	<u>0</u>	<u>166,000</u>	<u>(80,349)</u>	<u>0</u>	<u>0</u>	<u>85,651</u>
Net Change in Fund Balance	0	(451,826)	(35,031)	0	3,683	(483,174)
<b>Fund Balances at Beginning of Year</b>	5,394	1,138,628	3,404,559	24,822	14,979	4,588,382
<b>Fund Balances End of Year</b>	<u>\$ 5,394</u>	<u>\$ 686,802</u>	<u>\$ 3,369,528</u>	<u>\$ 24,822</u>	<u>\$ 18,662</u>	<u>\$ 4,105,208</u>

**MIAMI COUNTY, OHIO**

***Schedule of Revenues, Expenditures and Changes in  
Fund Balance – Budget and Actual (Non-GAAP Budgetary Basis)  
Major Funds – General Fund  
For the Year Ended December 31, 2004***

	Original Budget	Final Budget	Actual	Variance with Final Budget Positive (Negative)
<b>Revenues:</b>				
Taxes	\$ 10,668,600	\$ 11,404,600	\$ 12,405,253	\$ 1,000,653
Intergovernmental Revenues	2,478,500	2,861,976	3,001,637	139,661
Charges for Services	3,449,700	3,359,700	5,015,796	1,656,096
Licenses and Permits	450,100	450,100	536,159	86,059
Investment Earnings	600,000	600,000	773,422	173,422
Fines and Forfeitures	1,158,000	1,158,000	1,131,089	(26,911)
All Other Revenues	332,700	350,700	427,641	76,941
Total Revenues	19,137,600	20,185,076	23,290,997	3,105,921
<b>Expenditures:</b>				
Public Safety:				
Sheriff:				
Personal Services	6,722,800	6,722,800	6,480,793	242,007
Materials and Supplies	1,054,328	1,048,053	874,094	173,959
Contractual Services	1,053,699	1,059,320	961,501	97,819
Other Expenditures	2,900	2,900	336	2,564
Capital Outlay	237,832	248,450	238,300	10,150
Total Sheriff	9,071,559	9,081,523	8,555,024	526,499
Coroner:				
Personal Services	58,300	58,300	57,706	594
Travel and Transportation	300	120	120	0
Materials and Supplies	200	530	85	445
Contractual Services	92,550	92,399	86,885	5,514
Capital Outlay	2,500	2,500	0	2,500
Total Coroner	153,850	153,849	144,796	9,053
Adult Probation:				
Personal Services	120,300	123,744	122,677	1,067
Travel and Transportation	500	500	55	445
Materials and Supplies	11,211	10,318	9,378	940
Contractual Services	50,462	50,419	29,919	20,500
Capital Outlay	0	900	792	108
Total Adult Probation	182,473	185,881	162,821	23,060

(Continued)

**MIAMI COUNTY, OHIO**

***Schedule of Revenues, Expenditures and Changes in  
Fund Balance – Budget and Actual (Non-GAAP Budgetary Basis)  
Major Funds – General Fund  
For the Year Ended December 31, 2004***

	<u>Original Budget</u>	<u>Final Budget</u>	<u>Actual</u>	Variance with Final Budget Positive (Negative)
<b>Juvenile Probation:</b>				
Personal Services	320,600	353,450	348,307	5,143
Travel and Transportation	7,818	7,818	5,786	2,032
Materials and Supplies	3,100	3,100	2,507	593
Contractual Services	318,720	318,720	310,334	8,386
Total Juvenile Probation	<u>650,238</u>	<u>683,088</u>	<u>666,934</u>	<u>16,154</u>
<b>Emergency Management:</b>				
Personal Services	32,600	79,901	67,704	12,197
Travel and Transportation	1,200	1,200	361	839
Materials and Supplies	7,493	6,993	5,079	1,914
Contractual Services	9,041	22,456	19,828	2,628
Capital Outlay	3,400	400	0	400
Total Emergency Management	<u>53,734</u>	<u>110,950</u>	<u>92,972</u>	<u>17,978</u>
<b>Building Regulations:</b>				
Personal Services	401,900	424,295	423,842	453
Travel and Transportation	500	0	0	0
Materials and Supplies	12,666	14,566	12,844	1,722
Contractual Services	54,620	68,420	62,561	5,859
Other Expenditures	1,800	3,000	2,320	680
Capital Outlay	1,000	25,700	25,584	116
Total Building Regulations	<u>472,486</u>	<u>535,981</u>	<u>527,151</u>	<u>8,830</u>
Total Public Safety	<u>10,584,340</u>	<u>10,751,272</u>	<u>10,149,698</u>	<u>601,574</u>
<b>Health:</b>				
<b>Vital Statistics:</b>				
Contractual Services	2,500	2,500	0	2,500
Total Vital Statistics	<u>2,500</u>	<u>2,500</u>	<u>0</u>	<u>2,500</u>
<b>Children with Medical Handicaps:</b>				
Contractual Services	190,000	190,000	190,000	0
Total Children with Medical Handicaps	<u>190,000</u>	<u>190,000</u>	<u>190,000</u>	<u>0</u>

(Continued)

**MIAMI COUNTY, OHIO**

***Schedule of Revenues, Expenditures and Changes in  
Fund Balance – Budget and Actual (Non-GAAP Budgetary Basis)  
Major Funds – General Fund  
For the Year Ended December 31, 2004***

	<u>Original Budget</u>	<u>Final Budget</u>	<u>Actual</u>	Variance with Final Budget Positive (Negative)
<b>TB Patients:</b>				
Materials and Supplies	1,995	1,995	915	1,080
Contractual Services	3,835	3,835	3,614	221
Total TB Patients	<u>5,830</u>	<u>5,830</u>	<u>4,529</u>	<u>1,301</u>
Total Health	<u>198,330</u>	<u>198,330</u>	<u>194,529</u>	<u>3,801</u>
<b>Human Services:</b>				
<b>Victim Witness:</b>				
Contractual Services	83,000	83,000	83,000	0
Total Victim Witness	<u>83,000</u>	<u>83,000</u>	<u>83,000</u>	<u>0</u>
<b>County Home:</b>				
Materials and Supplies	3,000	3,861	2,815	1,046
Total County Home	<u>3,000</u>	<u>3,861</u>	<u>2,815</u>	<u>1,046</u>
<b>Children's Services:</b>				
Contractual Services	1,123,000	1,123,000	1,048,000	75,000
Total Children's Services	<u>1,123,000</u>	<u>1,123,000</u>	<u>1,048,000</u>	<u>75,000</u>
<b>Soldiers' Relief:</b>				
Personal Services	167,700	171,900	170,708	1,192
Travel and Transportation	8,200	8,200	5,879	2,321
Materials and Supplies	1,981	1,981	801	1,180
Contractual Services	301,200	290,720	238,699	52,021
Total Soldiers' Relief	<u>479,081</u>	<u>472,801</u>	<u>416,087</u>	<u>56,714</u>
<b>Veterans' Services:</b>				
Materials and Supplies	9,201	22,201	20,283	1,918
Contractual Services	30,400	27,880	20,194	7,686
Total Veterans' Services	<u>39,601</u>	<u>50,081</u>	<u>40,477</u>	<u>9,604</u>
<b>Public Assistance:</b>				
Contractual Services	269,100	269,100	269,080	20
Total Public Assistance	<u>269,100</u>	<u>269,100</u>	<u>269,080</u>	<u>20</u>
Total Human Services	<u>1,996,782</u>	<u>2,001,843</u>	<u>1,859,459</u>	<u>142,384</u>

(Continued)



**MIAMI COUNTY, OHIO**

***Schedule of Revenues, Expenditures and Changes in  
Fund Balance – Budget and Actual (Non-GAAP Budgetary Basis)  
Major Funds – General Fund  
For the Year Ended December 31, 2004***

	<u>Original Budget</u>	<u>Final Budget</u>	<u>Actual</u>	<u>Variance with Final Budget Positive (Negative)</u>
Conservation and Recreation:				
Recycle:				
Contractual Services	14,200	14,200	14,150	50
Total Recycle	<u>14,200</u>	<u>14,200</u>	<u>14,150</u>	<u>50</u>
Agriculture:				
Contractual Services	426,100	430,300	430,300	0
Total Agriculture	<u>426,100</u>	<u>430,300</u>	<u>430,300</u>	<u>0</u>
Neal Farm:				
Materials and Supplies	3,000	4,325	4,136	189
Total Neal Farm	<u>3,000</u>	<u>4,325</u>	<u>4,136</u>	<u>189</u>
Total Conservation and Recreation	<u>443,300</u>	<u>448,825</u>	<u>448,586</u>	<u>239</u>
Public Works:				
Transit System:				
Personal Services	89,000	91,800	57,805	33,995
Travel and Transportation	2,750	2,750	333	2,417
Materials and Supplies	107,944	99,244	97,365	1,879
Contractual Services	249,564	668,328	649,060	19,268
Capital Outlay	0	48,587	38,234	10,353
Total Public Works	<u>449,258</u>	<u>910,709</u>	<u>842,797</u>	<u>67,912</u>
General Government:				
Commissioners:				
Personal Services	547,300	565,671	523,685	41,986
Travel and Transportation	12,548	12,548	11,028	1,520
Materials and Supplies	4,087	4,087	3,403	684
Contractual Services	150,440	147,524	135,206	12,318
Total Commissioners	<u>714,375</u>	<u>729,830</u>	<u>673,322</u>	<u>56,508</u>
Auditor:				
Personal Services	584,600	597,500	568,394	29,106
Travel and Transportation	1,800	1,750	15	1,735
Materials and Supplies	17,366	17,366	13,065	4,301
Contractual Services	161,731	161,781	142,677	19,104
Other Expenditures	800	800	0	800
Total Auditor	<u>766,297</u>	<u>779,197</u>	<u>724,151</u>	<u>55,046</u>

(Continued)

**MIAMI COUNTY, OHIO**

***Schedule of Revenues, Expenditures and Changes in  
Fund Balance – Budget and Actual (Non-GAAP Budgetary Basis)  
Major Funds – General Fund  
For the Year Ended December 31, 2004***

	<u>Original Budget</u>	<u>Final Budget</u>	<u>Actual</u>	Variance with Final Budget Positive (Negative)
<b>Treasurer:</b>				
Personal Services	163,300	165,900	162,315	3,585
Travel and Transportation	1,500	1,500	827	673
Materials and Supplies	9,700	9,700	7,298	2,402
Contractual Services	38,800	43,800	34,263	9,537
Total Treasurer	<u>213,300</u>	<u>220,900</u>	<u>204,703</u>	<u>16,197</u>
<b>Prosecutor:</b>				
Personal Services	732,300	755,744	748,672	7,072
Travel and Transportation	15,350	9,850	4,936	4,914
Materials and Supplies	3,473	3,473	3,245	228
Contractual Services	122,874	128,374	108,220	20,154
Capital Outlay	1,500	1,500	0	1,500
Total Prosecutor	<u>875,497</u>	<u>898,941</u>	<u>865,073</u>	<u>33,868</u>
<b>Planning:</b>				
Personal Services	114,800	138,537	136,103	2,434
Travel and Transportation	5,961	5,960	3,553	2,407
Materials and Supplies	4,700	4,700	3,082	1,618
Contractual Services	148,003	101,986	71,290	30,696
Other Expenditures	300	300	0	300
Capital Outlay	4,000	4,000	2,815	1,185
Total Planning	<u>277,764</u>	<u>255,483</u>	<u>216,843</u>	<u>38,640</u>
<b>Data Processing:</b>				
Personal Services	98,900	101,180	96,104	5,076
Travel and Transportation	100	100	0	100
Materials and Supplies	48,662	48,662	44,065	4,597
Contractual Services	59,349	69,614	53,504	16,110
Capital Outlay	7,725	7,725	2,625	5,100
Total Data Processing	<u>214,736</u>	<u>227,281</u>	<u>196,298</u>	<u>30,983</u>
<b>Purchasing:</b>				
Personal Services	30,100	31,000	29,384	1,616
Materials and Supplies	96,968	109,556	95,705	13,851
Contractual Services	198,911	189,814	175,635	14,179
Capital Outlay	15,000	7,500	2,489	5,011
Total Purchasing	<u>340,979</u>	<u>337,870</u>	<u>303,213</u>	<u>34,657</u>

(Continued)

**MIAMI COUNTY, OHIO**

***Schedule of Revenues, Expenditures and Changes in  
Fund Balance – Budget and Actual (Non-GAAP Budgetary Basis)  
Major Funds – General Fund  
For the Year Ended December 31, 2004***

	<u>Original Budget</u>	<u>Final Budget</u>	<u>Actual</u>	Variance with Final Budget Positive (Negative)
<b>Poll Workers:</b>				
Personal Services	76,100	76,100	52,974	23,126
Total Poll Workers	<u>76,100</u>	<u>76,100</u>	<u>52,974</u>	<u>23,126</u>
<b>Elections:</b>				
Personal Services	187,000	193,058	191,351	1,707
Travel and Transportation	5,193	8,887	6,681	2,206
Materials and Supplies	74,313	74,136	72,061	2,075
Contractual Services	49,243	43,968	37,326	6,642
Capital Outlay	0	15,440	15,440	0
Total Elections	<u>315,749</u>	<u>335,489</u>	<u>322,859</u>	<u>12,630</u>
<b>Recorder:</b>				
Personal Services	256,500	263,926	261,039	2,887
Travel and Transportation	1,200	874	859	15
Materials and Supplies	8,800	6,777	5,994	783
Contractual Services	2,200	2,180	2,167	13
Other Expenditures	0	43	43	0
Total Recorder	<u>268,700</u>	<u>273,800</u>	<u>270,102</u>	<u>3,698</u>
<b>Microfilm:</b>				
Personal Services	58,900	60,400	37,942	22,458
Material and Supplies	15,000	15,000	10,284	4,716
Contractual Services	6,166	6,166	3,397	2,769
Total Microfilm	<u>80,066</u>	<u>81,566</u>	<u>51,623</u>	<u>29,943</u>
<b>Copiers:</b>				
Materials and Supplies	35,402	35,402	31,425	3,977
Contractual Services	189,868	189,868	173,476	16,392
Total Copiers	<u>225,270</u>	<u>225,270</u>	<u>204,901</u>	<u>20,369</u>
<b>Zoning:</b>				
Personal Services	149,800	119,563	75,849	43,714
Travel and Transportation	1,229	1,229	371	858
Materials and Supplies	5,239	5,239	4,867	372
Contractual Services	14,766	21,660	18,069	3,591
Other Expenditures	800	0	0	0
Total Zoning	<u>171,834</u>	<u>147,691</u>	<u>99,156</u>	<u>48,535</u>

(Continued)

**MIAMI COUNTY, OHIO**

***Schedule of Revenues, Expenditures and Changes in  
Fund Balance – Budget and Actual (Non-GAAP Budgetary Basis)  
Major Funds – General Fund  
For the Year Ended December 31, 2004***

	Original Budget	Final Budget	Actual	Variance with Final Budget Positive (Negative)
<b>Economic Development:</b>				
Personal Services	0	47,678	43,281	4,397
Travel and Transportation	0	1,500	1,174	326
Materials and Supplies	0	1,000	998	2
Contractual Services	0	26,000	9,759	16,241
Total Economic Development	0	76,178	55,212	20,966
<b>Maintenance and Operations:</b>				
Personal Services	508,100	526,027	515,278	10,749
Travel and Transportation	1,300	1,300	0	1,300
Materials and Supplies	134,313	148,813	128,227	20,586
Contractual Services	1,084,449	1,014,430	936,766	77,664
Capital Outlay	3,500	3,500	0	3,500
Total Maintenance and Operations	1,731,662	1,694,070	1,580,271	113,799
<b>Safety and Risk Management:</b>				
Personal Services	27,600	28,600	20,153	8,447
Travel and Transportation	2,964	2,964	521	2,443
Materials and Supplies	3,667	3,667	2,200	1,467
Contractual Services	3,300	3,300	800	2,500
Capital Outlay	2,000	2,000	0	2,000
Total Safety and Risk Management	39,531	40,531	23,674	16,857
<b>Annexations:</b>				
Other Expenditures	0	53	53	0
Total Annexations	0	53	53	0
<b>Contingencies:</b>				
Contractual Services	50,000	5,456	0	5,456
Total Contingencies	50,000	5,456	0	5,456
<b>Administration:</b>				
Personal Services	19,300	10,729	0	10,729
Travel and Transportation	1,000	1,000	0	1,000
Contractual Services	536,070	458,741	427,827	30,914
Other Expenditures	30,500	53,300	43,175	10,125
Total Administration	586,870	523,770	471,002	52,768

(Continued)

**MIAMI COUNTY, OHIO**

***Schedule of Revenues, Expenditures and Changes in  
Fund Balance – Budget and Actual (Non-GAAP Budgetary Basis)  
Major Funds – General Fund  
For the Year Ended December 31, 2004***

	Original Budget	Final Budget	Actual	Variance with Final Budget Positive (Negative)
Bureau of Inspection:				
Contractual Services	61,997	71,997	70,000	1,997
Total Bureau of Inspection	61,997	71,997	70,000	1,997
Family Coach Program:				
Personal Services	21,600	22,400	19,630	2,770
Travel and Transportation	1,100	1,100	507	593
Total Family Coach Program	22,700	23,500	20,137	3,363
Law Library:				
Personal Services	69,900	71,700	70,125	1,575
Total Law Library	69,900	71,700	70,125	1,575
Court of Appeals:				
Contractual Services	30,000	27,792	25,540	2,252
Total Court of Appeals	30,000	27,792	25,540	2,252
Common Pleas Court:				
Personal Services	477,200	493,410	483,691	9,719
Travel and Transportation	300	300	22	278
Materials and Supplies	13,628	13,628	6,454	7,174
Contractual Services	254,093	256,022	83,647	172,375
Total Common Pleas Court	745,221	763,360	573,814	189,546
Probate Court:				
Personal Services	212,000	217,788	202,320	15,468
Travel and Transportation	3,900	3,400	2,264	1,136
Materials and Supplies	7,689	7,689	5,709	1,980
Contractual Services	14,653	15,153	12,308	2,845
Total Probate Court	238,242	244,030	222,601	21,429
Municipal Court:				
Personal Services	1,413,400	1,444,599	1,381,054	63,545
Travel and Transportation	9,615	8,115	2,441	5,674
Materials and Supplies	168,349	165,349	143,533	21,816
Contractual Services	330,506	337,312	190,212	147,100
Other Expenditures	1,600	1,600	255	1,345
Capital Outlay	1,700	1,700	0	1,700
Total Municipal Court	1,925,170	1,958,675	1,717,495	241,180

(Continued)

**MIAMI COUNTY, OHIO**

---

***Schedule of Revenues, Expenditures and Changes in  
Fund Balance – Budget and Actual (Non-GAAP Budgetary Basis)  
Major Funds – General Fund  
For the Year Ended December 31, 2004***

---

	<u>Original Budget</u>	<u>Final Budget</u>	<u>Actual</u>	Variance with Final Budget Positive (Negative)
Jury Commission:				
Personal Services	34,300	42,222	41,761	461
Materials and Supplies	<u>2,222</u>	<u>2,222</u>	<u>2,222</u>	<u>0</u>
Total Jury Commission	36,522	44,444	43,983	461
Juvenile Court:				
Personal Services	461,000	505,700	474,671	31,029
Travel and Transportation	3,632	3,632	2,284	1,348
Materials and Supplies	11,905	13,205	12,018	1,187
Contractual Services	535,598	545,604	485,505	60,099
Other Expenditures	<u>0</u>	<u>224</u>	<u>224</u>	<u>0</u>
Total Juvenile Court	1,012,135	1,068,365	974,702	93,663
Municipal Court Prosecutor:				
Personal Services	67,400	69,600	68,979	621
Travel and Transportation	2,565	2,565	117	2,448
Contractual Services	<u>71,308</u>	<u>71,308</u>	<u>68,700</u>	<u>2,608</u>
Total Municipal Court Prosecutor	141,273	143,473	137,796	5,677
Clerk of Courts:				
Personal Services	349,500	359,400	352,705	6,695
Materials and Supplies	8,000	8,000	1,525	6,475
Contractual Services	<u>15,100</u>	<u>15,100</u>	<u>11,694</u>	<u>3,406</u>
Total Clerk of Courts	372,600	382,500	365,924	16,576
Public Defender:				
Contractual Services	<u>180,000</u>	<u>180,000</u>	<u>180,000</u>	<u>0</u>
Total Public Defender	180,000	180,000	180,000	0
Dispute Resolution:				
Contractual Services	<u>28,300</u>	<u>28,300</u>	<u>28,300</u>	<u>0</u>
Total Dispute Resolution	28,300	28,300	28,300	0
Magistrate:				
Contractual Services	<u>0</u>	<u>4,640</u>	<u>4,640</u>	<u>0</u>
Total Magistrate	0	4,640	4,640	0

(Continued)

**MIAMI COUNTY, OHIO**

***Schedule of Revenues, Expenditures and Changes in  
Fund Balance – Budget and Actual (Non-GAAP Budgetary Basis)  
Major Funds – General Fund  
For the Year Ended December 31, 2004***

	Original Budget	Final Budget	Actual	Variance with Final Budget Positive (Negative)
Engineer:				
Personal Services	209,100	214,000	212,246	1,754
Materials and Supplies	5,000	5,000	4,606	394
Contractual Services	1,000	1,000	795	205
Total Engineer	215,100	220,000	217,647	2,353
Total General Government	12,027,890	12,162,252	10,968,134	1,194,118
Total Expenditures	25,699,900	26,473,231	24,463,203	2,010,028
Excess (Deficiency) of				
Revenues Over (Under) Expenditures	(6,562,300)	(6,288,155)	(1,172,206)	5,115,949
<b>Other Financing Sources (Uses):</b>				
Transfers In	0	0	94,931	94,931
Transfers Out	(333,500)	(502,916)	(502,123)	793
Advances In	47,500	47,500	590,572	543,072
Advances Out	0	(555,572)	(555,572)	0
Total Other Financing Sources (Uses)	(286,000)	(1,010,988)	(372,192)	638,796
Net Change in Fund Balance	(6,848,300)	(7,299,143)	(1,544,398)	5,754,745
Fund Balance at Beginning of Year	15,030,562	15,030,562	15,030,562	0
Prior Year Encumbrances	904,027	904,027	904,027	0
Fund Balance at End of Year	\$ 9,086,289	\$ 8,635,446	\$ 14,390,191	\$ 5,754,745

**MIAMI COUNTY, OHIO**

***Schedule of Revenues, Expenditures and Changes in  
Fund Balance – Budget and Actual (Non-GAAP Budgetary Basis)  
Major Funds – Special Revenue Fund  
For the Year Ended December 31, 2004***

**MOTOR VEHICLE AND GASOLINE TAX FUND**

	Original Budget	Final Budget	Actual	Variance with Final Budget Positive (Negative)
<b>Revenues:</b>				
Taxes	\$ 614,200	\$ 614,200	\$ 585,535	\$ (28,665)
Intergovernmental Revenues	4,330,000	4,330,000	4,714,289	384,289
Charges for Services	460,000	428,220	393,502	(34,718)
Investment Earnings	25,000	25,000	16,647	(8,353)
Fines and Forfeitures	76,000	76,000	77,678	1,678
All Other Revenues	80,400	80,400	103,265	22,865
Total Revenues	5,585,600	5,553,820	5,890,916	337,096
<b>Expenditures:</b>				
Public Works:				
Engineering:				
Personal Services	761,900	814,676	787,098	27,578
Travel and Transportation	1,250	1,250	657	593
Materials and Supplies	205,236	231,433	200,574	30,859
Contractual Services	651,500	678,259	629,922	48,337
Other Expenditures	240,972	17,339	7,118	10,221
Capital Outlay	60,000	75,432	63,333	12,099
Total Engineering	1,920,858	1,818,389	1,688,702	129,687
Roads:				
Personal Services	1,976,000	2,077,635	1,996,311	81,324
Travel and Transportation	1,000	1,000	281	719
Materials and Supplies	851,481	971,981	733,555	238,426
Contractual Services	1,361,395	1,614,086	1,337,919	276,167
Other Expenditures	1,200	1,200	404	796
Capital Outlay	223,000	287,520	278,809	8,711
Total Roads	4,414,076	4,953,422	4,347,279	606,143
Total Expenditures	6,334,934	6,771,811	6,035,981	735,830
Excess (Deficiency) of				
Revenues Over (Under) Expenditures	(749,334)	(1,217,991)	(145,065)	1,072,926
Fund Balance at Beginning of Year	1,267,730	1,267,730	1,267,730	0
Prior Year Encumbrances	229,161	229,161	229,161	0
Fund Balance at End of Year	\$ 747,557	\$ 278,900	\$ 1,351,826	\$ 1,072,926



**MIAMI COUNTY, OHIO**

***Schedule of Revenues, Expenditures and Changes in  
Fund Balance – Budget and Actual (Non-GAAP Budgetary Basis)  
Major Funds – Special Revenue Fund  
For the Year Ended December 31, 2004***

	Original Budget	Final Budget	Actual	Variance with Final Budget Positive (Negative)
<b>Revenues:</b>				
Intergovernmental Revenues	\$ 4,855,000	\$ 5,339,205	\$ 3,966,645	\$ (1,372,560)
Charges for Services	10,000	10,000	16,030	6,030
All Other Revenues	241,100	241,100	303,875	62,775
Total Revenues	5,106,100	5,590,305	4,286,550	(1,303,755)
<b>Expenditures:</b>				
Human Services:				
Public Assistance:				
Personal Services	1,913,470	1,921,520	1,869,827	51,693
Travel and Transportation	5,540	5,540	3,440	2,100
Materials and Supplies	66,159	69,159	48,175	20,984
Contractual Services	956,373	1,218,483	870,161	348,322
Other Expenditures	2,500	6,000	4,345	1,655
Capital Outlay	26,000	58,980	57,911	1,069
Total Public Assistance	2,970,042	3,279,682	2,853,859	425,823
Job and Family Services:				
Travel and Transportation	19,413	29,413	16,884	12,529
Material and Supplies	6,020	16,419	3,927	12,492
Contractual Services	343,301	619,751	334,053	285,698
Capital Outlay	1,000	3,600	1,713	1,887
Total Job and Family Services	369,734	669,183	356,577	312,606
Public Social Services:				
Contractual Services	1,764,307	1,879,324	1,381,979	497,345
Total Public Social Services	1,764,307	1,879,324	1,381,979	497,345
Total Expenditures	5,104,083	5,828,189	4,592,415	1,235,774
Excess (Deficiency) of Revenues Over (Under) Expenditures	2,017	(237,884)	(305,865)	(67,981)
<b>Other Financing Sources (Uses):</b>				
Transfers Out	(186,175)	(186,175)	(186,174)	1
Total Other Financing Sources (Uses)	(186,175)	(186,175)	(186,174)	1
Net Change in Fund Balance	(184,158)	(424,059)	(492,039)	(67,980)
Fund Balance at Beginning of Year	606,087	606,087	606,087	0
Prior Year Encumbrances	299,990	299,990	299,990	0
Fund Balance at End of Year	\$ 721,919	\$ 482,018	\$ 414,038	\$ (67,980)

**MIAMI COUNTY, OHIO**

***Schedule of Revenues, Expenditures and Changes in  
Fund Balance – Budget and Actual (Non-GAAP Budgetary Basis)  
Major Funds – Special Revenue Fund  
For the Year Ended December 31, 2004***

**MENTAL RETARDATION AND DEVELOPMENTAL DISABILITIES BOARD FUND**

	Original Budget	Final Budget	Actual	Variance with Final Budget Positive (Negative)
<b>Revenues:</b>				
Taxes	\$ 6,772,695	\$ 6,772,695	\$ 6,855,823	\$ 83,128
Intergovernmental Revenues	2,369,797	2,369,797	2,524,776	154,979
Charges for Services	71,867	71,867	80,747	8,880
Investment Earnings	0	0	2,004	2,004
All Other Revenues	38,378	38,378	44,298	5,920
Total Revenues	9,252,737	9,252,737	9,507,648	254,911
<b>Expenditures:</b>				
Health:				
Riverside School:				
Personal Services	7,252,751	7,374,885	7,352,270	22,615
Travel and Transportation	98,100	96,599	76,782	19,817
Materials and Supplies	302,292	287,842	255,368	32,474
Contractual Services	2,486,929	2,396,447	2,288,234	108,213
Other Expenditures	1,500	1,500	862	638
Capital Outlay	285,814	263,987	262,002	1,985
Total Riverside School	10,427,386	10,421,260	10,235,518	185,742
Gifts and Donations:				
Materials and Supplies	7,351	11,057	10,059	998
Contractual Services	5,649	6,348	3,668	2,680
Capital Outlay	0	1,719	1,568	151
Total Gifts and Donations	13,000	19,124	15,295	3,829
Total Expenditures	10,440,386	10,440,384	10,250,813	189,571
Excess (Deficiency) of				
Revenues Over (Under) Expenditures	(1,187,649)	(1,187,647)	(743,165)	444,482
Fund Balance at Beginning of Year	6,101,447	6,101,447	6,101,447	0
Prior Year Encumbrances	217,857	217,857	217,857	0
Fund Balance at End of Year	\$ 5,131,655	\$ 5,131,657	\$ 5,576,139	\$ 444,482

**MIAMI COUNTY, OHIO**

***Schedule of Revenues, Expenditures and Changes in  
Fund Balance – Budget and Actual (Non-GAAP Budgetary Basis)  
Nonmajor Special Revenue Funds  
For the Year Ended December 31, 2004***

<b>CHILD SUPPORT ENFORCEMENT AGENCY FUND</b>			Variance with Final Budget Positive (Negative)
	Final Budget	Actual	
<b>Revenues:</b>			
Intergovernmental Revenues	\$ 1,175,000	\$ 854,582	\$ (320,418)
Charges for Services	250,500	357,714	107,214
All Other Revenues	20,100	29,017	8,917
Total Revenues	1,445,600	1,241,313	(204,287)
<b>Expenditures:</b>			
Human Services:			
Child Support Enforcement:			
Personal Services	742,620	688,454	54,166
Travel and Transportation	835	730	105
Materials and Supplies	2,500	178	2,322
Contractual Services	858,091	749,075	109,016
Other Expenditures	1,000	0	1,000
Total Expenditures	1,605,046	1,438,437	166,609
Excess (Deficiency) of Revenues Over (Under) Expenditures	(159,446)	(197,124)	(37,678)
Fund Balance at Beginning of Year	1,635,930	1,635,930	0
Prior Year Encumbrances	58,977	58,977	0
Fund Balance at End of Year	\$ 1,535,461	\$ 1,497,783	\$ (37,678)

**MIAMI COUNTY, OHIO**

---

***Schedule of Revenues, Expenditures and Changes in  
Fund Balance – Budget and Actual (Non-GAAP Budgetary Basis)  
Nonmajor Special Revenue Funds  
For the Year Ended December 31, 2004***

---

	Final Budget	Actual	Variance with Final Budget Positive (Negative)
<b>DOG AND KENNEL FUND</b>			
<b>Revenues:</b>			
Charges for Services	\$ 259,800	\$ 260,350	\$ 550
Fines and Forfeitures	19,300	16,787	(2,513)
All Other Revenues	0	153	153
Total Revenues	<u>279,100</u>	<u>277,290</u>	<u>(1,810)</u>
<b>Expenditures:</b>			
Health:			
Dog and Kennel:			
Personal Services	230,260	226,861	3,399
Travel and Transportation	2,409	2,054	355
Materials and Supplies	13,726	11,866	1,860
Contractual Services	40,211	36,254	3,957
Other Expenditures	630	468	162
Total Expenditures	<u>287,236</u>	<u>277,503</u>	<u>9,733</u>
Excess (Deficiency) of Revenues Over (Under) Expenditures	(8,136)	(213)	7,923
Fund Balance at Beginning of Year	108,920	108,920	0
Prior Year Encumbrances	8,266	8,266	0
Fund Balance at End of Year	<u>\$ 109,050</u>	<u>\$ 116,973</u>	<u>\$ 7,923</u>

**MIAMI COUNTY, OHIO**

***Schedule of Revenues, Expenditures and Changes in  
Fund Balance – Budget and Actual (Non-GAAP Budgetary Basis)  
Nonmajor Special Revenue Funds  
For the Year Ended December 31, 2004***

<b>SHELTER/DOMESTIC VIOLENCE FUND</b>			
	Final Budget	Actual	Variance with Final Budget Positive (Negative)
<b>Revenues:</b>			
Intergovernmental Revenues	\$ 269,424	\$ 174,529	\$ (94,895)
All Other Revenues	9,181	8,681	(500)
Total Revenues	278,605	183,210	(95,395)
<b>Expenditures:</b>			
Human Services:			
Victim Witness Program:			
Personal Services	175,005	172,982	2,023
Materials and Supplies	1,195	303	892
Contractual Services	5,517	4,628	889
Other Expenditures	3,566	851	2,715
Capital Outlay	5,919	5,350	569
Total Expenditures	191,202	184,114	7,088
Excess (Deficiency) of Revenues Over (Under) Expenditures	87,403	(904)	(88,307)
Fund Balance at Beginning of Year	43,867	43,867	0
Prior Year Encumbrances	853	853	0
Fund Balance at End of Year	\$ 132,123	\$ 43,816	\$ (88,307)

**MIAMI COUNTY, OHIO**

***Schedule of Revenues, Expenditures and Changes in  
Fund Balance – Budget and Actual (Non-GAAP Budgetary Basis)  
Nonmajor Special Revenue Funds  
For the Year Ended December 31, 2004***

	<u>Final Budget</u>	<u>Actual</u>	Variance with Final Budget Positive (Negative)
<b>YOUTH SERVICES SUBSIDY FUND</b>			
<b>Revenues:</b>			
Intergovernmental Revenues	\$ 313,456	\$ 339,939	\$ 26,483
Charges for Services	601,360	563,767	(37,593)
All Other Revenues	5,557	9,302	3,745
Total Revenues	<u>920,373</u>	<u>913,008</u>	<u>(7,365)</u>
<b>Expenditures:</b>			
Public Safety:			
Juvenile Court:			
Personal Services	202,054	193,405	8,649
Materials and Supplies	52	52	0
Contractual Services	173,396	100,425	72,971
Other Expenditures	1,252	1,252	0
Capital Outlay	1,199	0	1,199
Total Public Safety	<u>377,953</u>	<u>295,134</u>	<u>82,819</u>
Human Services:			
Miami County Youth Center:			
Personal Services	499,640	451,736	47,904
Material and Supplies	32,483	27,847	4,636
Contractual Services	193,073	186,866	6,207
Other Expenditures	10,970	10,499	471
Capital Outlay	2,593	754	1,839
Total Human Services	<u>738,759</u>	<u>677,702</u>	<u>61,057</u>
Total Expenditures	<u>1,116,712</u>	<u>972,836</u>	<u>143,876</u>
Excess (Deficiency) of Revenues Over (Under) Expenditures	(196,339)	(59,828)	136,511
<b>Other Financing Sources (Uses):</b>			
Advances In	0	15,000	15,000
Advances Out	(15,000)	(15,000)	0
Total Other Financing Sources (Uses)	<u>(15,000)</u>	<u>0</u>	<u>15,000</u>
Net Change in Fund Balance	(211,339)	(59,828)	151,511
Fund Balance at Beginning of Year	347,958	347,958	0
Prior Year Encumbrances	118,024	118,024	0
Fund Balance at End of Year	<u>\$ 254,643</u>	<u>\$ 406,154</u>	<u>\$ 151,511</u>

**MIAMI COUNTY, OHIO**

***Schedule of Revenues, Expenditures and Changes in  
Fund Balance – Budget and Actual (Non-GAAP Budgetary Basis)  
Nonmajor Special Revenue Funds  
For the Year Ended December 31, 2004***

<b>E-911 EMERGENCY OPERATIONS FUND</b>			Variance with Final Budget Positive (Negative)
	Final Budget	Actual	
<b>Revenues:</b>			
Taxes	\$ 1,840,000	\$ 2,055,381	\$ 215,381
Charges for Services	118,600	89,532	(29,068)
All Other Revenues	0	70,031	70,031
Total Revenues	1,958,600	2,214,944	256,344
<b>Expenditures:</b>			
Public Safety:			
Communications Center:			
Personal Services	1,317,200	1,200,736	116,464
Travel and Transportation	5,060	2,197	2,863
Materials and Supplies	31,033	23,447	7,586
Contractual Services	745,698	606,345	139,353
Capital Outlay	206,812	205,896	916
Total Expenditures	2,305,803	2,038,621	267,182
Excess (Deficiency) of Revenues Over (Under) Expenditures	(347,203)	176,323	523,526
Fund Balance at Beginning of Year	1,064,310	1,064,310	0
Prior Year Encumbrances	205,852	205,852	0
Fund Balance at End of Year	\$ 922,959	\$ 1,446,485	\$ 523,526

**MIAMI COUNTY, OHIO**

---

***Schedule of Revenues, Expenditures and Changes in  
Fund Balance – Budget and Actual (Non-GAAP Budgetary Basis)  
Nonmajor Special Revenue Funds  
For the Year Ended December 31, 2004***

---

	<u>Final Budget</u>	<u>Actual</u>	Variance with Final Budget Positive (Negative)
<b>Revenues:</b>			
Intergovernmental Revenues	\$ 330,000	\$ 329,121	\$ (879)
Charges for Services	56,000	60,696	4,696
Total Revenues	<u>386,000</u>	<u>389,817</u>	<u>3,817</u>
<b>Expenditures:</b>			
General Government:			
Indigent Guardianship:			
Materials and Supplies	308	300	8
Contractual Services	22,384	6,880	15,504
Capital Outlay	<u>29,000</u>	<u>23,303</u>	<u>5,697</u>
Total Indigent Guardianship	51,692	30,483	21,209
Public Defender:			
Personal Services	371,063	368,326	2,737
Travel and Transportation	500	497	3
Materials and Supplies	2,091	1,858	233
Contractual Services	9,016	5,698	3,318
Capital Outlay	<u>4,464</u>	<u>4,464</u>	<u>0</u>
Total Public Defender	<u>387,134</u>	<u>380,843</u>	<u>6,291</u>
Total Expenditures	<u>438,826</u>	<u>411,326</u>	<u>27,500</u>
Excess (Deficiency) of Revenues Over (Under) Expenditures	(52,826)	(21,509)	31,317
Fund Balance at Beginning of Year	187,248	187,248	0
Prior Year Encumbrances	<u>34,598</u>	<u>34,598</u>	<u>0</u>
Fund Balance at End of Year	<u>\$ 169,020</u>	<u>\$ 200,337</u>	<u>\$ 31,317</u>



**MIAMI COUNTY, OHIO**

---

***Schedule of Revenues, Expenditures and Changes in  
Fund Balance – Budget and Actual (Non-GAAP Budgetary Basis)  
Nonmajor Special Revenue Funds  
For the Year Ended December 31, 2004***

---

<b>DELINQUENT TAX COLLECTION FUND</b>			Variance with Final Budget Positive (Negative)
	Final Budget	Actual	
<b>Revenues:</b>			
Charges for Services	\$ 73,700	\$ 148,286	\$ 74,586
All Other Revenues	0	1,713	1,713
Total Revenues	73,700	149,999	76,299
<b>Expenditures:</b>			
General Government:			
Treasurer:			
Personal Services	57,013	56,643	370
Total Treasurer	57,013	56,643	370
Prosecutor:			
Personal Services	47,500	40,862	6,638
Contractual Services	9,000	3,363	5,637
Total Prosecutor	56,500	44,225	12,275
Total Expenditures	113,513	100,868	12,645
Excess (Deficiency) of Revenues Over (Under) Expenditures	(39,813)	49,131	88,944
Fund Balance at Beginning of Year	118,218	118,218	0
Fund Balance at End of Year	\$ 78,405	\$ 167,349	\$ 88,944

**MIAMI COUNTY, OHIO**

---

***Schedule of Revenues, Expenditures and Changes in  
Fund Balance – Budget and Actual (Non-GAAP Budgetary Basis)  
Nonmajor Special Revenue Funds  
For the Year Ended December 31, 2004***

---

<b>REAL ESTATE APPRAISAL FUND</b>			
	Final Budget	Actual	Variance with Final Budget Positive (Negative)
<b>Revenues:</b>			
Charges for Services	\$ 772,500	\$ 881,042	\$ 108,542
Licenses and Permits	100	30	(70)
Total Revenues	772,600	881,072	108,472
<b>Expenditures:</b>			
General Government:			
Auditor:			
Personal Services	502,400	422,688	79,712
Travel and Transportation	2,600	0	2,600
Materials and Supplies	7,479	3,169	4,310
Contractual Services	644,412	209,527	434,885
Other Expenditures	200	0	200
Capital Outlay	98,130	19,723	78,407
Total Expenditures	1,255,221	655,107	600,114
Excess (Deficiency) of Revenues Over (Under) Expenditures	(482,621)	225,965	708,586
Fund Balance at Beginning of Year	390,540	390,540	0
Prior Year Encumbrances	143,322	143,322	0
Fund Balance at End of Year	\$ 51,241	\$ 759,827	\$ 708,586

**MIAMI COUNTY, OHIO**

---

***Schedule of Revenues, Expenditures and Changes in  
Fund Balance – Budget and Actual (Non-GAAP Budgetary Basis)  
Nonmajor Special Revenue Funds  
For the Year Ended December 31, 2004***

---

	<u>Final Budget</u>	<u>Actual</u>	Variance with Final Budget Positive (Negative)
<b>Revenues:</b>			
Intergovernmental Revenues	\$ 87,980	\$ 87,978	\$ (2)
Total Revenues	<u>87,980</u>	<u>87,978</u>	<u>(2)</u>
<b>Expenditures:</b>			
General Government:			
Municipal Court:			
Personal Services	85,133	83,850	1,283
Contractual Services	<u>4,314</u>	<u>4,315</u>	<u>(1)</u>
Total Expenditures	<u>89,447</u>	<u>88,165</u>	<u>1,282</u>
Excess (Deficiency) of Revenues Over (Under) Expenditures	(1,467)	(187)	1,280
Fund Balance at Beginning of Year	15,521	15,521	0
Prior Year Encumbrances	<u>308</u>	<u>308</u>	<u>0</u>
Fund Balance at End of Year	<u>\$ 14,362</u>	<u>\$ 15,642</u>	<u>\$ 1,280</u>

**MIAMI COUNTY, OHIO**

---

***Schedule of Revenues, Expenditures and Changes in  
Fund Balance – Budget and Actual (Non-GAAP Budgetary Basis)  
Nonmajor Special Revenue Funds  
For the Year Ended December 31, 2004***

---

COUNTY CONSERVANCY FUND			Variance with Final Budget Positive (Negative)
	Final Budget	Actual	
<b>Revenues:</b>			
Taxes	\$ 51,800	\$ 54,826	\$ 3,026
Intergovernmental Revenues	5,400	7,381	1,981
Total Revenues	57,200	62,207	5,007
<b>Expenditures:</b>			
Conservation and Recreation:			
Auditor:			
Contractual Services	47,750	47,450	300
Total Expenditures	47,750	47,450	300
Excess (Deficiency) of			
Revenues Over (Under) Expenditures	9,450	14,757	5,307
Fund Balance at Beginning of Year	73,041	73,041	0
Fund Balance at End of Year	\$ 82,491	\$ 87,798	\$ 5,307

**MIAMI COUNTY, OHIO**

---

***Schedule of Revenues, Expenditures and Changes in  
Fund Balance – Budget and Actual (Non-GAAP Budgetary Basis)  
Nonmajor Special Revenue Funds  
For the Year Ended December 31, 2004***

---

	<u>Final Budget</u>	<u>Actual</u>	Variance with Final Budget Positive (Negative)
<b>Revenues:</b>			
Intergovernmental Revenues	\$ 86,154	\$ 86,653	\$ 499
Total Revenues	<u>86,154</u>	<u>86,653</u>	<u>499</u>
<b>Expenditures:</b>			
General Government:			
Common Pleas Court:			
Personal Services	88,926	88,734	192
Contractual Services	426	426	0
Total Expenditures	<u>89,352</u>	<u>89,160</u>	<u>192</u>
Excess (Deficiency) of			
Revenues Over (Under) Expenditures	(3,198)	(2,507)	691
Fund Balance at Beginning of Year	43,483	43,483	0
Prior Year Encumbrances	426	426	0
Fund Balance at End of Year	<u>\$ 40,711</u>	<u>\$ 41,402</u>	<u>\$ 691</u>

**MIAMI COUNTY, OHIO**

---

***Schedule of Revenues, Expenditures and Changes in  
Fund Balance – Budget and Actual (Non-GAAP Budgetary Basis)  
Nonmajor Special Revenue Funds  
For the Year Ended December 31, 2004***

---

		<b>SUPER CLEANUP FUND</b>		Variance with Final Budget Positive (Negative)
		<u>Final Budget</u>	<u>Actual</u>	<u>(Negative)</u>
<b>Revenues:</b>				
Taxes		\$ 200,000	\$ 205,538	\$ 5,538
Total Revenues		<u>200,000</u>	<u>205,538</u>	<u>5,538</u>
<b>Expenditures:</b>				
Public Works:				
Transfer Station:				
Materials and Supplies		9,829	9,702	127
Contractual Services		<u>261,180</u>	<u>240,652</u>	<u>20,528</u>
Total Expenditures		<u>271,009</u>	<u>250,354</u>	<u>20,655</u>
Excess (Deficiency) of				
Revenues Over (Under) Expenditures		(71,009)	(44,816)	26,193
Fund Balance at Beginning of Year		18,658	18,658	0
Prior Year Encumbrances		<u>52,351</u>	<u>52,351</u>	<u>0</u>
Fund Balance at End of Year		<u>\$ 0</u>	<u>\$ 26,193</u>	<u>\$ 26,193</u>

**MIAMI COUNTY, OHIO**

---

***Schedule of Revenues, Expenditures and Changes in  
Fund Balance – Budget and Actual (Non-GAAP Budgetary Basis)  
Nonmajor Special Revenue Funds  
For the Year Ended December 31, 2004***

---

<b>EMERGENCY MANAGEMENT AGENCY FUND</b>			Variance with Final Budget Positive (Negative)
	Final Budget	Actual	
<b>Revenues:</b>			
Intergovernmental Revenues	\$ 633,532	\$ 571,215	\$ (62,317)
All Other Revenues	0	3,006	3,006
Total Revenues	633,532	574,221	(59,311)
<b>Expenditures:</b>			
Public Safety:			
Emergency Management:			
Materials and Supplies	65,313	58,531	6,782
Contractual Services	73,237	70,456	2,781
Capital Outlay	492,295	485,510	6,785
Total Expenditures	630,845	614,497	16,348
Excess (Deficiency) of Revenues Over (Under) Expenditures	2,687	(40,276)	(42,963)
Fund Balance at Beginning of Year	25,801	25,801	0
Prior Year Encumbrances	86,860	86,860	0
Fund Balance at End of Year	\$ 115,348	\$ 72,385	\$ (42,963)

**MIAMI COUNTY, OHIO**

---

***Schedule of Revenues, Expenditures and Changes in  
Fund Balance – Budget and Actual (Non-GAAP Budgetary Basis)  
Nonmajor Special Revenue Funds  
For the Year Ended December 31, 2004***

---

	Final Budget	Actual	Variance with Final Budget Positive (Negative)
<b>ENFORCEMENT AND EDUCATION FUND</b>			
<b>Revenues:</b>			
Intergovernmental Revenues	\$ 9,900	\$ 7,601	\$ (2,299)
Fines and Forfeitures	8,500	10,755	2,255
All Other Revenues	0	37	37
Total Revenues	<u>18,400</u>	<u>18,393</u>	<u>(7)</u>
<b>Expenditures:</b>			
Public Safety:			
Sheriff:			
Materials and Supplies	16,340	12,324	4,016
Total Public Safety	<u>16,340</u>	<u>12,324</u>	<u>4,016</u>
General Government:			
Municipal Court:			
Contractual Services	19,090	19,090	0
Total General Government	<u>19,090</u>	<u>19,090</u>	<u>0</u>
Total Expenditures	<u>35,430</u>	<u>31,414</u>	<u>4,016</u>
Excess (Deficiency) of Revenues Over (Under) Expenditures	(17,030)	(13,021)	4,009
Fund Balance at Beginning of Year	31,702	31,702	0
Prior Year Encumbrances	12,999	12,999	0
Fund Balance at End of Year	<u>\$ 27,671</u>	<u>\$ 31,680</u>	<u>\$ 4,009</u>



**MIAMI COUNTY, OHIO**

***Schedule of Revenues, Expenditures and Changes in  
Fund Balance – Budget and Actual (Non-GAAP Budgetary Basis)  
Nonmajor Special Revenue Funds  
For the Year Ended December 31, 2004***

	Final Budget	Actual	Variance with Final Budget Positive (Negative)
<b>JUVENILE DETENTION/REHABILITATION CENTER FUND</b>			
<b>Revenues:</b>			
Intergovernmental Revenues	\$ 1,480,334	\$ 1,346,105	\$ (134,229)
Charges for Services	2,116,769	2,091,140	(25,629)
All Other Revenues	3,760	2,820	(940)
Total Revenues	3,600,863	3,440,065	(160,798)
<b>Expenditures:</b>			
Public Safety:			
Juvenile Court:			
Personal Services	1,219,596	1,141,506	78,090
Travel and Transportation	5,989	2,647	3,342
Materials and Supplies	114,622	85,312	29,310
Contractual Services	281,159	260,966	20,193
Other Expenditures	1,000	967	33
Capital Outlay	52,055	50,906	1,149
Total Juvenile Court	1,674,421	1,542,304	132,117
West Central Rehabilitation:			
Personal Services	1,530,402	1,440,790	89,612
Travel and Transportation	4,329	1,058	3,271
Materials and Supplies	113,819	81,438	32,381
Contractual Services	338,601	281,084	57,517
Other Expenditures	1,615	1,615	0
Capital Outlay	79,265	50,241	29,024
Total West Central Rehabilitation	2,068,031	1,856,226	211,805
Total Expenditures	3,742,452	3,398,530	343,922
Excess (Deficiency) of			
Revenues Over (Under) Expenditures	(141,589)	41,535	183,124
<b>Other Financing Sources (Uses):</b>			
Transfers Out	(225,000)	(225,000)	0
Total Other Financing Sources (Uses)	(225,000)	(225,000)	0
Net Change in Fund Balance	(366,589)	(183,465)	183,124
Fund Balance at Beginning of Year	1,048,571	1,048,571	0
Prior Year Encumbrances	195,671	195,671	0
Fund Balance at End of Year	\$ 877,653	\$ 1,060,777	\$ 183,124

**MIAMI COUNTY, OHIO**

---

***Schedule of Revenues, Expenditures and Changes in  
Fund Balance – Budget and Actual (Non-GAAP Budgetary Basis)  
Nonmajor Special Revenue Funds  
For the Year Ended December 31, 2004***

---

	Final Budget	Actual	Variance with Final Budget Positive (Negative)
<b>COUNTY PROBATION SERVICES FUND</b>			
<b>Revenues:</b>			
Intergovernmental Revenues	\$ 38,739	\$ 38,739	\$ 0
Charges for Services	250,000	256,184	6,184
All Other Revenues	0	204	204
Total Revenues	<u>288,739</u>	<u>295,127</u>	<u>6,388</u>
<b>Expenditures:</b>			
General Government:			
Municipal Court:			
Personal Services	263,388	252,153	11,235
Materials and Supplies	608	601	7
Contractual Services	123,126	120,388	2,738
Other Expenditures	400	191	209
Total Expenditures	<u>387,522</u>	<u>373,333</u>	<u>14,189</u>
Excess (Deficiency) of Revenues Over (Under) Expenditures	(98,783)	(78,206)	20,577
Fund Balance at Beginning of Year	301,794	301,794	0
Prior Year Encumbrances	11,013	11,013	0
Fund Balance at End of Year	<u>\$ 214,024</u>	<u>\$ 234,601</u>	<u>\$ 20,577</u>

**MIAMI COUNTY, OHIO**

---

***Schedule of Revenues, Expenditures and Changes in  
Fund Balance – Budget and Actual (Non-GAAP Budgetary Basis)  
Nonmajor Special Revenue Funds  
For the Year Ended December 31, 2004***

---

	<u>Final Budget</u>	<u>Actual</u>	Variance with Final Budget Positive (Negative)
<b>Revenues:</b>			
Intergovernmental Revenues	\$ 70,750	\$ 68,835	\$ (1,915)
Total Revenues	<u>70,750</u>	<u>68,835</u>	<u>(1,915)</u>
<b>Expenditures:</b>			
General Government:			
Municipal Court:			
Personal Services	62,328	57,260	5,068
Materials and Supplies	2,964	2,735	229
Contractual Services	<u>5,768</u>	<u>5,320</u>	<u>448</u>
Total Expenditures	<u>71,060</u>	<u>65,315</u>	<u>5,745</u>
Excess (Deficiency) of			
Revenues Over (Under) Expenditures	(310)	3,520	3,830
Fund Balance at Beginning of Year	5,583	5,583	0
Prior Year Encumbrances	<u>775</u>	<u>775</u>	<u>0</u>
Fund Balance at End of Year	<u>\$ 6,048</u>	<u>\$ 9,878</u>	<u>\$ 3,830</u>

**MIAMI COUNTY, OHIO**

---

***Schedule of Revenues, Expenditures and Changes in  
Fund Balance – Budget and Actual (Non-GAAP Budgetary Basis)  
Nonmajor Special Revenue Funds  
For the Year Ended December 31, 2004***

---

	Final Budget	Actual	Variance with Final Budget Positive (Negative)
<b>Revenues:</b>			
All Other Revenues	\$ 0	\$ 1	\$ 1
Total Revenues	<u>0</u>	<u>1</u>	<u>1</u>
<b>Expenditures:</b>			
Total Expenditures	<u>0</u>	<u>0</u>	<u>0</u>
Excess (Deficiency) of Revenues Over (Under) Expenditures	0	1	1
Fund Balance at Beginning of Year	<u>88</u>	<u>88</u>	<u>0</u>
Fund Balance at End of Year	<u><u>\$ 88</u></u>	<u><u>\$ 89</u></u>	<u><u>\$ 1</u></u>

**MIAMI COUNTY, OHIO**

---

***Schedule of Revenues, Expenditures and Changes in  
Fund Balance – Budget and Actual (Non-GAAP Budgetary Basis)  
Nonmajor Special Revenue Funds  
For the Year Ended December 31, 2004***

---

	Final Budget	Actual	Variance with Final Budget Positive (Negative)
<b>Revenues:</b>			
Intergovernmental Revenues	\$ 12,854	\$ 12,854	\$ 0
Total Revenues	<u>12,854</u>	<u>12,854</u>	<u>0</u>
<b>Expenditures:</b>			
Public Works:			
Contractual Services	12,854	12,854	0
Total Expenditures	<u>12,854</u>	<u>12,854</u>	<u>0</u>
Excess (Deficiency) of Revenues Over (Under) Expenditures	0	0	0
<b>Other Financing Sources (Uses):</b>			
Advances In	190,572	190,572	0
Advances Out	<u>(190,572)</u>	<u>(190,572)</u>	<u>0</u>
Total Other Financing Sources (Uses)	<u>0</u>	<u>0</u>	<u>0</u>
Net Change in Fund Balance	0	0	0
Fund Balance at Beginning of Year	<u>7,630</u>	<u>7,630</u>	<u>0</u>
Fund Balance at End of Year	<u>\$ 7,630</u>	<u>\$ 7,630</u>	<u>\$ 0</u>

**MIAMI COUNTY, OHIO**

***Schedule of Revenues, Expenditures and Changes in  
Fund Balance – Budget and Actual (Non-GAAP Budgetary Basis)  
Nonmajor Special Revenue Funds  
For the Year Ended December 31, 2004***

	Final Budget	Actual	Variance with Final Budget Positive (Negative)
<b>COMMUNITY DEVELOPMENT BLOCK GRANT FUND</b>			
<b>Revenues:</b>			
Intergovernmental Revenues	\$ 1,726,360	\$ 893,293	\$ (833,067)
All Other Revenues	3,744	8,963	5,219
Total Revenues	1,730,104	902,256	(827,848)
<b>Expenditures:</b>			
Public Works:			
Commissioners:			
Travel and Transportation	2,000	50	1,950
Contractual Services	905,717	418,529	487,188
Capital Outlay	2,000	0	2,000
Total Commissioners	909,717	418,579	491,138
Community Development:			
Materials and Supplies	2,500	0	2,500
Contractual Services	766,643	294,828	471,815
Total Community Development	769,143	294,828	474,315
Total Expenditures	1,678,860	713,407	965,453
Excess (Deficiency) of Revenues Over (Under) Expenditures	51,244	188,849	137,605
<b>Other Financing Sources (Uses):</b>			
Advances In	0	50,000	50,000
Advances Out	(50,000)	(50,000)	0
Total Other Financing Sources (Uses)	(50,000)	0	50,000
Net Change in Fund Balance	1,244	188,849	187,605
Fund Balance at Beginning of Year	74,058	74,058	0
Prior Year Encumbrances	160,860	160,860	0
Fund Balance at End of Year	\$ 236,162	\$ 423,767	\$ 187,605

**MIAMI COUNTY, OHIO**

***Schedule of Revenues, Expenditures and Changes in  
Fund Balance – Budget and Actual (Non-GAAP Budgetary Basis)  
Nonmajor Special Revenue Funds  
For the Year Ended December 31, 2004***

<b>CHILDREN'S SERVICES BOARD FUND</b>			
	Final Budget	Actual	Variance with Final Budget Positive (Negative)
<b>Revenues:</b>			
Intergovernmental Revenues	\$ 2,986,387	\$ 2,814,358	\$ (172,029)
Charges for Services	1,064,858	1,229,874	165,016
All Other Revenues	42,548	42,468	(80)
Total Revenues	4,093,793	4,086,700	(7,093)
<b>Expenditures:</b>			
Human Services:			
Commissioners:			
Personal Services	144,971	141,026	3,945
Travel and Transportation	5,029	3,862	1,167
Materials and Supplies	7,326	5,614	1,712
Contractual Services	68,327	64,165	4,162
Other Expenditures	5,500	5,500	0
Capital Outlay	3,107	3,107	0
Total Commissioners	234,260	223,274	10,986
Children's Services:			
Personal Services	1,526,862	1,475,405	51,457
Travel and Transportation	25,685	24,004	1,681
Materials and Supplies	74,757	61,358	13,399
Contractual Services	2,764,031	2,672,914	91,117
Other Expenditures	11,905	3,276	8,629
Capital Outlay	3,357	3,357	0
Total Children's Services	4,406,597	4,240,314	166,283
Children's Home Farm:			
Materials and Supplies	8,953	4,794	4,159
Contractual Services	17,376	14,876	2,500
Total Children's Home Farm	26,329	19,670	6,659
Total Expenditures	4,667,186	4,483,258	183,928
Excess (Deficiency) of Revenues Over (Under) Expenditures	(573,393)	(396,558)	176,835
Fund Balance at Beginning of Year	386,318	386,318	0
Prior Year Encumbrances	279,308	279,308	0
Fund Balance at End of Year	\$ 92,233	\$ 269,068	\$ 176,835

**MIAMI COUNTY, OHIO**

---

***Schedule of Revenues, Expenditures and Changes in  
Fund Balance – Budget and Actual (Non-GAAP Budgetary Basis)  
Nonmajor Special Revenue Funds  
For the Year Ended December 31, 2004***

---

	Final Budget	Actual	Variance with Final Budget Positive (Negative)
<b>LEGAL RESEARCH FUND</b>			
<b>Revenues:</b>			
Charges for Services	\$ 9,790	\$ 9,580	\$ (210)
Fines and Forfeitures	2,200	2,174	(26)
Total Revenues	11,990	11,754	(236)
<b>Expenditures:</b>			
General Government:			
Common Pleas Court:			
Contractual Services	3,284	2,356	928
Total Common Pleas Court	3,284	2,356	928
Juvenile Court:			
Materials and Supplies	1,624	1,442	182
Capital Outlay	14,000	4,570	9,430
Total Juvenile Court	15,624	6,012	9,612
Probate Court:			
Contractual Services	3,614	3,614	0
Total Probate Court	3,614	3,614	0
Total Expenditures	22,522	11,982	10,540
Excess (Deficiency) of Revenues Over (Under) Expenditures	(10,532)	(228)	10,304
Fund Balance at Beginning of Year	26,692	26,692	0
Prior Year Encumbrances	1,108	1,108	0
Fund Balance at End of Year	\$ 17,268	\$ 27,572	\$ 10,304



**MIAMI COUNTY, OHIO**

***Schedule of Revenues, Expenditures and Changes in  
Fund Balance – Budget and Actual (Non-GAAP Budgetary Basis)  
Nonmajor Special Revenue Funds  
For the Year Ended December 31, 2004***

	Final Budget	Actual	Variance with Final Budget Positive (Negative)
<b>ONE-STOP SHOP FUND</b>			
<b>Revenues:</b>			
Charges for Services	\$ 463,300	\$ 503,824	\$ 40,524
All Other Revenues	200	416	216
Total Revenues	463,500	504,240	40,740
<b>Expenditures:</b>			
General Government:			
Commissioners:			
Contractual Services	123,032	122,467	565
Total Commissioners	123,032	122,467	565
Clerk of Courts:			
Personal Services	292,700	286,172	6,528
Travel and Transportation	2,000	509	1,491
Materials and Supplies	22,800	6,817	15,983
Contractual Services	66,285	47,664	18,621
Capital Outlay	7,710	3,710	4,000
Total Clerk of Courts	391,495	344,872	46,623
Total Expenditures	514,527	467,339	47,188
Excess (Deficiency) of Revenues Over (Under) Expenditures	(51,027)	36,901	87,928
<b>Other Financing Sources (Uses):</b>			
Transfers Out	(96,290)	(94,931)	1,359
Total Other Financing Sources (Uses)	(96,290)	(94,931)	1,359
Net Change in Fund Balance	(147,317)	(58,030)	89,287
Fund Balance at Beginning of Year	477,150	477,150	0
Prior Year Encumbrances	13,617	13,617	0
Fund Balance at End of Year	\$ 343,450	\$ 432,737	\$ 89,287

**MIAMI COUNTY, OHIO**

---

***Schedule of Revenues, Expenditures and Changes in  
Fund Balance – Budget and Actual (Non-GAAP Budgetary Basis)  
Nonmajor Special Revenue Funds  
For the Year Ended December 31, 2004***

---

	Final Budget	Actual	Variance with Final Budget Positive (Negative)
<b>LAW ENFORCEMENT FUND</b>			
<b>Revenues:</b>			
Intergovernmental Revenues	\$ 2,765	\$ 2,608	\$ (157)
Charges for Services	35,000	24,282	(10,718)
Fines and Forfeitures	3,000	2,199	(801)
Total Revenues	<u>40,765</u>	<u>29,089</u>	<u>(11,676)</u>
<b>Expenditures:</b>			
Public Safety:			
Sheriff:			
Materials and Supplies	14,646	4,395	10,251
Contractual Services	33,905	19,905	14,000
Total Expenditures	<u>48,551</u>	<u>24,300</u>	<u>24,251</u>
Excess (Deficiency) of Revenues Over (Under) Expenditures	(7,786)	4,789	12,575
Fund Balance at Beginning of Year	46,614	46,614	0
Fund Balance at End of Year	<u>\$ 38,828</u>	<u>\$ 51,403</u>	<u>\$ 12,575</u>

**MIAMI COUNTY, OHIO**

---

***Schedule of Revenues, Expenditures and Changes in  
Fund Balance – Budget and Actual (Non-GAAP Budgetary Basis)  
Nonmajor Special Revenue Funds  
For the Year Ended December 31, 2004***

---

	<u>Final Budget</u>	<u>Actual</u>	Variance with Final Budget Positive (Negative)
<b>COUNTY RECORDER EQUIPMENT FUND</b>			
<b>Revenues:</b>			
Charges for Services	\$ 100,000	\$ 99,032	\$ (968)
Total Revenues	<u>100,000</u>	<u>99,032</u>	<u>(968)</u>
<b>Expenditures:</b>			
General Government:			
Recorder:			
Materials and Supplies	5,473	5,469	4
Contractual Services	16,708	15,994	714
Capital Outlay	<u>70,030</u>	<u>10,211</u>	<u>59,819</u>
Total Expenditures	<u>92,211</u>	<u>31,674</u>	<u>60,537</u>
Excess (Deficiency) of			
Revenues Over (Under) Expenditures	7,789	67,358	59,569
Fund Balance at Beginning of Year	85,465	85,465	0
Prior Year Encumbrances	<u>10,211</u>	<u>10,211</u>	<u>0</u>
Fund Balance at End of Year	<u>\$ 103,465</u>	<u>\$ 163,034</u>	<u>\$ 59,569</u>

**MIAMI COUNTY, OHIO**

***Schedule of Revenues, Expenditures and Changes in  
Fund Balance – Budget and Actual (Non-GAAP Budgetary Basis)  
Nonmajor Special Revenue Funds  
For the Year Ended December 31, 2004***

	<u>Final Budget</u>	<u>Actual</u>	<u>Variance with Final Budget Positive (Negative)</u>
<b>Revenues:</b>			
Charges for Services	\$ 312,000	\$ 258,224	\$ (53,776)
All Other Revenues	0	154	154
Total Revenues	<u>312,000</u>	<u>258,378</u>	<u>(53,622)</u>
<b>Expenditures:</b>			
General Government:			
Municipal Court:			
Personal Services	112,849	110,848	2,001
Travel and Transportation	1,200	0	1,200
Materials and Supplies	18,840	10,724	8,116
Contractual Services	70,557	46,007	24,550
Capital Outlay	163,369	31,188	132,181
Total Municipal Court	<u>366,815</u>	<u>198,767</u>	<u>168,048</u>
Common Pleas Court:			
Materials and Supplies	6,000	0	6,000
Contractual Services	12,000	0	12,000
Total Common Pleas Court	<u>18,000</u>	<u>0</u>	<u>18,000</u>
Probate Court:			
Materials and Supplies	5,618	1,926	3,692
Contractual Services	27,912	23,500	4,412
Capital Outlay	6,000	0	6,000
Total Probate Court	<u>39,530</u>	<u>25,426</u>	<u>14,104</u>
Juvenile Court:			
Personal Services	6,600	6,335	265
Travel and Transportation	1,000	222	778
Materials and Supplies	1,000	444	556
Contractual Services	6,500	5,000	1,500
Capital Outlay	22,920	18,180	4,740
Total Juvenile Court	<u>38,020</u>	<u>30,181</u>	<u>7,839</u>
Total Expenditures	<u>462,365</u>	<u>254,374</u>	<u>207,991</u>
Excess (Deficiency) of Revenues Over (Under) Expenditures	(150,365)	4,004	154,369
Fund Balance at Beginning of Year	629,396	629,396	0
Prior Year Encumbrances	37,647	37,647	0
Fund Balance at End of Year	<u>\$ 516,678</u>	<u>\$ 671,047</u>	<u>\$ 154,369</u>

**MIAMI COUNTY, OHIO**

---

***Schedule of Revenues, Expenditures and Changes in  
Fund Balance – Budget and Actual (Non-GAAP Budgetary Basis)  
Nonmajor Special Revenue Funds  
For the Year Ended December 31, 2004***

---

<b>D.A.R.E. FUND</b>		<u>Final Budget</u>	<u>Actual</u>	Variance with Final Budget Positive (Negative)
<b>Revenues:</b>				
Intergovernmental Revenues		\$ 0	\$ 8,115	\$ 8,115
Total Revenues		<u>0</u>	<u>8,115</u>	<u>8,115</u>
<b>Expenditures:</b>				
Sheriff:				
Personal Services		13,214	13,214	0
Total Expenditures		<u>13,214</u>	<u>13,214</u>	<u>0</u>
Excess (Deficiency) of				
Revenues Over (Under) Expenditures		(13,214)	(5,099)	8,115
Fund Balance at Beginning of Year		<u>13,216</u>	<u>13,216</u>	<u>0</u>
Fund Balance at End of Year		<u>\$ 2</u>	<u>\$ 8,117</u>	<u>\$ 8,115</u>

**MIAMI COUNTY, OHIO**

***Schedule of Revenues, Expenditures and Changes in  
Fund Balance – Budget and Actual (Non-GAAP Budgetary Basis)  
Nonmajor Special Revenue Funds  
For the Year Ended December 31, 2004***

	<u>Final Budget</u>	<u>Actual</u>	<u>Variance with Final Budget Positive (Negative)</u>
<b>DISPUTE RESOLUTION FUND</b>			
<b>Revenues:</b>			
Intergovernmental Revenues	\$ 28,300	\$ 32,940	\$ 4,640
Fines and Forfeitures	126,700	113,790	(12,910)
Total Revenues	<u>155,000</u>	<u>146,730</u>	<u>(8,270)</u>
<b>Expenditures:</b>			
General Government:			
Municipal Court:			
Personal Services	154,031	146,091	7,940
Travel and Transportation	547	84	463
Materials and Supplies	1,043	1,043	0
Contractual Services	850	630	220
Total Municipal Court	<u>156,471</u>	<u>147,848</u>	<u>8,623</u>
Juvenile Court:			
Personal Services	17,100	12,387	4,713
Travel and Transportation	2,000	0	2,000
Contractual Services	14,000	9,100	4,900
Total Juvenile Court	<u>33,100</u>	<u>21,487</u>	<u>11,613</u>
Total Expenditures	<u>189,571</u>	<u>169,335</u>	<u>20,236</u>
Excess (Deficiency) of Revenues Over (Under) Expenditures	(34,571)	(22,605)	11,966
Fund Balance at Beginning of Year	94,441	94,441	0
Prior Year Encumbrances	3,940	3,940	0
Fund Balance at End of Year	<u>\$ 63,810</u>	<u>\$ 75,776</u>	<u>\$ 11,966</u>

**MIAMI COUNTY, OHIO**

---

***Schedule of Revenues, Expenditures and Changes in  
Fund Balance – Budget and Actual (Non-GAAP Budgetary Basis)  
Nonmajor Special Revenue Funds  
For the Year Ended December 31, 2004***

---

	COPS MORE '96 FUND		Variance with Final Budget Positive (Negative)
	Final Budget	Actual	
<b>Revenues:</b>			
Intergovernmental Revenues	\$ 50,000	\$ 49,999	\$ (1)
Total Revenues	50,000	49,999	(1)
<b>Expenditures:</b>			
Public Safety:			
Sheriff:			
Personal Services	129,472	111,730	17,742
Total Expenditures	129,472	111,730	17,742
Excess (Deficiency) of			
Revenues Over (Under) Expenditures	(79,472)	(61,731)	17,741
Fund Balance at Beginning of Year	91,472	91,472	0
Fund Balance at End of Year	\$ 12,000	\$ 29,741	\$ 17,741

**MIAMI COUNTY, OHIO**

---

***Schedule of Revenues, Expenditures and Changes in  
Fund Balance – Budget and Actual (Non-GAAP Budgetary Basis)  
Nonmajor Special Revenue Funds  
For the Year Ended December 31, 2004***

---

	COMMISSARY FUND		Variance with Final Budget Positive (Negative)
	Final Budget	Actual	
<b>Revenues:</b>			
Charges for Services	\$ 216,000	\$ 238,052	\$ 22,052
All Other Revenues	0	173	173
Total Revenues	216,000	238,225	22,225
<b>Expenditures:</b>			
Public Safety:			
Sheriff:			
Materials and Supplies	193,352	174,920	18,432
Contractual Services	80,446	67,919	12,527
Other Expenditures	10,250	8,719	1,531
Total Expenditures	284,048	251,558	32,490
Excess (Deficiency) of Revenues Over (Under) Expenditures	(68,048)	(13,333)	54,715
Fund Balance at Beginning of Year	47,296	47,296	0
Prior Year Encumbrances	20,751	20,751	0
Fund Balance at End of Year	\$ (1)	\$ 54,714	\$ 54,715



**MIAMI COUNTY, OHIO**

---

***Schedule of Revenues, Expenditures and Changes in  
Fund Balance – Budget and Actual (Non-GAAP Budgetary Basis)  
Nonmajor Special Revenue Funds  
For the Year Ended December 31, 2004***

---

	<u>Final Budget</u>	<u>Actual</u>	Variance with Final Budget Positive (Negative)
<b>FOOD SERVICES FUND</b>			
<b>Revenues:</b>			
Intergovernmental Revenues	\$ 160,500	\$ 172,901	\$ 12,401
All Other Revenues	7,039	0	(7,039)
Total Revenues	<u>167,539</u>	<u>172,901</u>	<u>5,362</u>
<b>Expenditures:</b>			
Public Safety:			
Sheriff:			
Materials and Supplies	42,500	0	42,500
Total Sheriff	<u>42,500</u>	<u>0</u>	<u>42,500</u>
West Central Rehabilitation:			
Materials and Supplies	129,155	98,271	30,884
Total West Central Rehabilitation	<u>129,155</u>	<u>98,271</u>	<u>30,884</u>
Total Public Safety	<u>171,655</u>	<u>98,271</u>	<u>73,384</u>
Human Services:			
Miami County Youth Center:			
Materials and Supplies	22,051	21,724	327
Total Human Services	<u>22,051</u>	<u>21,724</u>	<u>327</u>
Total Expenditures	<u>193,706</u>	<u>119,995</u>	<u>73,711</u>
Excess (Deficiency) of Revenues Over (Under) Expenditures	(26,167)	52,906	79,073
Fund Balance at Beginning of Year	34,144	34,144	0
Prior Year Encumbrances	23,588	23,588	0
Fund Balance at End of Year	<u>\$ 31,565</u>	<u>\$ 110,638</u>	<u>\$ 79,073</u>

**MIAMI COUNTY, OHIO**

---

***Schedule of Revenues, Expenditures and Changes in  
Fund Balance – Budget and Actual (Non-GAAP Budgetary Basis)  
Nonmajor Special Revenue Funds  
For the Year Ended December 31, 2004***

---

	Final Budget	Actual	Variance with Final Budget Positive (Negative)
<b>COMMON PLEAS COURT - SPECIAL PROJECTS FUND</b>			
<b>Revenues:</b>			
Charges for Services	\$ 114,000	\$ 141,789	\$ 27,789
Total Revenues	<u>114,000</u>	<u>141,789</u>	<u>27,789</u>
<b>Expenditures:</b>			
Health:			
Personal Services	46,981	41,354	5,627
Travel and Transportation	5,000	3,898	1,102
Contractual Services	46,000	29,137	16,863
Capital Outlay	<u>6,000</u>	<u>0</u>	<u>6,000</u>
Total Expenditures	<u>103,981</u>	<u>74,389</u>	<u>29,592</u>
Excess (Deficiency) of Revenues Over (Under) Expenditures	10,019	67,400	57,381
Fund Balance at Beginning of Year	<u>123,392</u>	<u>123,392</u>	<u>0</u>
Fund Balance at End of Year	<u>\$ 133,411</u>	<u>\$ 190,792</u>	<u>\$ 57,381</u>

**MIAMI COUNTY, OHIO**

---

***Schedule of Revenues, Expenditures and Changes in  
Fund Balance – Budget and Actual (Non-GAAP Budgetary Basis)  
Nonmajor Special Revenue Funds  
For the Year Ended December 31, 2004***

---

		Final Budget	Actual	Variance with Final Budget Positive (Negative)
<b>Revenues:</b>				
	Total Revenues	\$ 0	\$ 0	\$ 0
<b>Expenditures:</b>				
	Public Safety:			
	Sheriff:			
	Total Expenditures	0	0	0
	Excess (Deficiency) of Revenues Over (Under) Expenditures	0	0	0
	Fund Balance at Beginning of Year	2,920	2,920	0
	Fund Balance at End of Year	<u>\$ 2,920</u>	<u>\$ 2,920</u>	<u>\$ 0</u>

**MIAMI COUNTY, OHIO**

---

***Schedule of Revenues, Expenditures and Changes in  
Fund Balance – Budget and Actual (Non-GAAP Budgetary Basis)  
Nonmajor Special Revenue Funds  
For the Year Ended December 31, 2004***

---

<b>MUNICIPAL COURT RESTITUTION FUND</b>			Variance with Final Budget Positive (Negative)
	<u>Final Budget</u>	<u>Actual</u>	
<b>Revenues:</b>			
All Other Revenues	\$ 72,500	\$ 76,010	\$ 3,510
Total Revenues	<u>72,500</u>	<u>76,010</u>	<u>3,510</u>
<b>Expenditures:</b>			
General Government:			
Municipal Court:			
Contractual Services	76,063	76,060	3
Other Expenditures	<u>40</u>	<u>40</u>	<u>0</u>
Total Expenditures	<u>76,103</u>	<u>76,100</u>	<u>3</u>
Excess (Deficiency) of			
Revenues Over (Under) Expenditures	(3,603)	(90)	3,513
Fund Balance at Beginning of Year	<u>3,603</u>	<u>3,603</u>	<u>0</u>
Fund Balance at End of Year	<u><u>\$ 0</u></u>	<u><u>\$ 3,513</u></u>	<u><u>\$ 3,513</u></u>

**MIAMI COUNTY, OHIO**

---

***Schedule of Revenues, Expenditures and Changes in  
Fund Balance – Budget and Actual (Non-GAAP Budgetary Basis)  
Nonmajor Special Revenue Funds  
For the Year Ended December 31, 2004***

---

<b>CHILDREN'S SERVICES TRUST FUND</b>			Variance with Final Budget Positive (Negative)
	Final Budget	Actual	
<b>Revenues:</b>			
Investment Earnings	\$ 1,500	\$ 1,292	\$ (208)
Total Revenues	1,500	1,292	(208)
<b>Expenditures:</b>			
Human Services:			
Children's Services:			
Contractual Services	1,500	0	1,500
Total Expenditures	1,500	0	1,500
Excess (Deficiency) of			
Revenues Over (Under) Expenditures	0	1,292	1,292
Fund Balance at Beginning of Year	26,845	26,845	0
Fund Balance at End of Year	\$ 26,845	\$ 28,137	\$ 1,292

**MIAMI COUNTY, OHIO**

---

***Schedule of Revenues, Expenditures and Changes in  
Fund Balance – Budget and Actual (Non-GAAP Budgetary Basis)  
Nonmajor Special Revenue Funds  
For the Year Ended December 31, 2004***

---

	Final Budget	Actual	Variance with Final Budget Positive (Negative)
<b>D.A.R.E. TRUST FUND</b>			
<b>Revenues:</b>			
All Other Revenues	\$ 0	\$ 600	\$ 600
Total Revenues	<u>0</u>	<u>600</u>	<u>600</u>
<b>Expenditures:</b>			
Total Expenditures	<u>0</u>	<u>0</u>	<u>0</u>
Excess (Deficiency) of Revenues Over (Under) Expenditures	0	600	600
Fund Balance at Beginning of Year	<u>5,383</u>	<u>5,383</u>	<u>0</u>
Fund Balance at End of Year	<u><u>\$ 5,383</u></u>	<u><u>\$ 5,983</u></u>	<u><u>\$ 600</u></u>

**MIAMI COUNTY, OHIO**

---

***Schedule of Revenues, Expenditures and Changes in  
Fund Balance – Budget and Actual (Non-GAAP Budgetary Basis)  
Nonmajor Debt Service Funds  
For the Year Ended December 31, 2004***

---

<b>GENERAL OBLIGATION DEBT FUND</b>			
	<u>Final Budget</u>	<u>Actual</u>	Variance with Final Budget Positive (Negative)
<b>Revenues:</b>			
All Other Revenues	\$ 0	\$ 583	\$ 583
Total Revenues	<u>0</u>	<u>583</u>	<u>583</u>
<b>Expenditures:</b>			
Debt Service:			
Principal Retirement	511,709	510,053	1,656
Interest and Fiscal Charges	<u>310,471</u>	<u>309,554</u>	<u>917</u>
Total Expenditures	<u>822,180</u>	<u>819,607</u>	<u>2,573</u>
Excess (Deficiency) of Revenues Over (Under) Expenditures	(822,180)	(819,024)	3,156
<b>Other Financing Sources (Uses):</b>			
Transfers In	<u>799,300</u>	<u>827,646</u>	<u>28,346</u>
Total Other Financing Sources (Uses)	<u>799,300</u>	<u>827,646</u>	<u>28,346</u>
Net Change in Fund Balance	(22,880)	8,622	31,502
Fund Balance at Beginning of Year	<u>78,154</u>	<u>78,154</u>	<u>0</u>
Fund Balance at End of Year	<u>\$ 55,274</u>	<u>\$ 86,776</u>	<u>\$ 31,502</u>

**MIAMI COUNTY, OHIO**

---

***Schedule of Revenues, Expenditures and Changes in  
Fund Balance – Budget and Actual (Non-GAAP Budgetary Basis)  
Nonmajor Debt Service Funds  
For the Year Ended December 31, 2004***

---

<b>SPECIAL ASSESSMENT DEBT FUND</b>			
	<u>Final Budget</u>	<u>Actual</u>	Variance with Final Budget Positive (Negative)
<b>Revenues:</b>			
Total Revenues	\$ 0	\$ 0	\$ 0
<b>Expenditures:</b>			
Total Expenditures	<u>0</u>	<u>0</u>	<u>0</u>
Excess (Deficiency) of Revenues Over (Under) Expenditures	0	0	0
Fund Balance at Beginning of Year	<u>2,729</u>	<u>2,729</u>	<u>0</u>
Fund Balance at End of Year	<u><u>\$ 2,729</u></u>	<u><u>\$ 2,729</u></u>	<u><u>\$ 0</u></u>



**MIAMI COUNTY, OHIO**

---

***Schedule of Revenues, Expenditures and Changes in  
Fund Balance – Budget and Actual (Non-GAAP Budgetary Basis)  
Nonmajor Capital Projects Funds  
For the Year Ended December 31, 2004***

---

<b>SEWER SYSTEM IMPROVEMENT FUND</b>			Variance with Final Budget Positive (Negative)
	<u>Final Budget</u>	<u>Actual</u>	
<b>Revenues:</b>			
Total Revenues	<u>\$ 0</u>	<u>\$ 0</u>	<u>\$ 0</u>
<b>Expenditures:</b>			
Total Expenditures	<u>0</u>	<u>0</u>	<u>0</u>
Excess (Deficiency) of Revenues Over (Under) Expenditures	0	0	0
Fund Balance at Beginning of Year	<u>5,394</u>	<u>5,394</u>	<u>0</u>
Fund Balance at End of Year	<u><u>\$ 5,394</u></u>	<u><u>\$ 5,394</u></u>	<u><u>\$ 0</u></u>

**MIAMI COUNTY, OHIO**

***Schedule of Revenues, Expenditures and Changes in  
Fund Balance – Budget and Actual (Non-GAAP Budgetary Basis)  
Nonmajor Capital Projects Funds  
For the Year Ended December 31, 2004***

<b>PERMANENT IMPROVEMENT FUND</b>			Variance with Final Budget Positive (Negative)
	Final Budget	Actual	
<b>Revenues:</b>			
Charges for Services	\$ 25,000	\$ 15,249	\$ (9,751)
All Other Revenues	6,604	77	(6,527)
Total Revenues	31,604	15,326	(16,278)
<b>Expenditures:</b>			
Capital Outlay:			
Commissioners:			
Capital Outlay	958,150	745,298	212,852
Total Expenditures	958,150	745,298	212,852
Excess (Deficiency) of Revenues Over (Under) Expenditures	(926,546)	(729,972)	196,574
<b>Other Financing Sources (Uses):</b>			
Transfers In	0	166,000	166,000
Total Other Financing Sources (Uses)	0	166,000	166,000
Net Change in Fund Balance	(926,546)	(563,972)	362,574
Fund Balance at Beginning of Year	928,423	928,423	0
Prior Year Encumbrances	297,879	297,879	0
Fund Balance at End of Year	\$ 299,756	\$ 662,330	\$ 362,574

**MIAMI COUNTY, OHIO**

---

***Schedule of Revenues, Expenditures and Changes in  
Fund Balance – Budget and Actual (Non-GAAP Budgetary Basis)  
Nonmajor Capital Projects Funds  
For the Year Ended December 31, 2004***

---

	Final Budget	Actual	Variance with Final Budget Positive (Negative)
<b>Revenues:</b>			
Investment Earnings	\$ 50,000	\$ 42,547	\$ (7,453)
Total Revenues	<u>50,000</u>	<u>42,547</u>	<u>(7,453)</u>
<b>Expenditures:</b>			
Total Expenditures	<u>0</u>	<u>0</u>	<u>0</u>
Excess (Deficiency) of Revenues Over (Under) Expenditures	50,000	42,547	(7,453)
<b>Other Financing Sources (Uses):</b>			
Transfers Out	<u>(85,000)</u>	<u>(80,349)</u>	<u>4,651</u>
Total Other Financing Sources (Uses)	<u>(85,000)</u>	<u>(80,349)</u>	<u>4,651</u>
Net Change in Fund Balance	(35,000)	(37,802)	(2,802)
Fund Balance at Beginning of Year	<u>3,401,484</u>	<u>3,401,484</u>	<u>0</u>
Fund Balance at End of Year	<u><u>\$ 3,366,484</u></u>	<u><u>\$ 3,363,682</u></u>	<u><u>\$ (2,802)</u></u>

**MIAMI COUNTY, OHIO**

---

***Schedule of Revenues, Expenditures and Changes in  
Fund Balance – Budget and Actual (Non-GAAP Budgetary Basis)  
Nonmajor Capital Projects Funds  
For the Year Ended December 31, 2004***

---

	Final Budget	Actual	Variance with Final Budget Positive (Negative)
<b>Revenues:</b>			
Total Revenues	\$ 0	\$ 0	\$ 0
<b>Expenditures:</b>			
Total Expenditures	0	0	0
Excess (Deficiency) of Revenues Over (Under) Expenditures	0	0	0
<b>Other Financing Sources (Uses):</b>			
Transfers Out	(24,822)	0	24,822
Total Other Financing Sources (Uses)	(24,822)	0	24,822
Net Change in Fund Balance	(24,822)	0	24,822
Fund Balance at Beginning of Year	24,822	24,822	0
Fund Balance at End of Year	<u>\$ 0</u>	<u>\$ 24,822</u>	<u>\$ 24,822</u>

**MIAMI COUNTY, OHIO**

---

***Schedule of Revenues, Expenditures and Changes in  
Fund Balance – Budget and Actual (Non-GAAP Budgetary Basis)  
Nonmajor Capital Projects Funds  
For the Year Ended December 31, 2004***

---

	Final Budget	Actual	Variance with Final Budget Positive (Negative)
<b>Revenues:</b>			
All Other Revenues	\$ 8,000	\$ 7,385	\$ (615)
Total Revenues	<u>8,000</u>	<u>7,385</u>	<u>(615)</u>
<b>Expenditures:</b>			
Capital Outlay:			
Engineer:			
Capital Outlay	8,000	3,702	4,298
Total Expenditures	<u>8,000</u>	<u>3,702</u>	<u>4,298</u>
Excess (Deficiency) of Revenues Over (Under) Expenditures	0	3,683	3,683
Fund Balance at Beginning of Year	<u>14,979</u>	<u>14,979</u>	<u>0</u>
Fund Balance at End of Year	<u><u>\$ 14,979</u></u>	<u><u>\$ 18,662</u></u>	<u><u>\$ 3,683</u></u>

***Fiduciary Funds***

---

Fiduciary fund types are used to account for assets held by the County in a trustee capacity or as an agent for individuals, private organizations, other governmental units and/or other funds.

***Agency Funds***

---

**Payroll Deductions Fund**

To maintain and account for the accumulation of payroll withholdings until payment is remitted to third parties.

**Workers' Compensation Fund**

To maintain and account for the accumulation of workers' compensation premiums from various County departments and other agencies and the disbursement of same to the Ohio Bureau of Workers' Compensation.

**Local Government Fund**

To maintain and account for the accumulation and disbursement of state revenue sharing monies.

**Auto Registration Fund**

To maintain and account for the accumulation and disbursement of automobile license and registration fee collections.

**Township Gas Fund**

To maintain and account for the accumulation and disbursement of gasoline tax collections.

**Cigarette Tax Fund**

To maintain and account for the accumulation and disbursement of cigarette tax collections.

**Special Emergency Planning Fund**

To maintain and account for the accumulation and disbursement of reimbursements from the state for expenses incurred for emergency planning.

**Inheritance Tax Fund**

To maintain and account for the accumulation and disbursement of inheritance tax collections.

(Continued)

***Agency Funds***

---

**Law Library Fund**

To maintain and account for the accumulation and disbursement of resources for the law library.

**Undivided Tax Settlement Fund**

To maintain and account for the accumulation and disbursement of property tax collections.

**Special Assessment Collection Fund**

To maintain and account for the accumulation and disbursement of special assessments.

**Tri-County Board Fund**

To maintain and account for the accumulation and disbursement of resources for the Tri-County Board of Alcohol, Drug and Mental Health Services.

**County Court Agency Fund**

To maintain and account for the accumulation and disbursement of court fees and fines.

**General County Agency Fund**

To maintain and account for the accumulation and disbursement of County fees and other similar resources and uses.

**Other County Agencies Fund**

To maintain and account for research, fees, licenses, donations and other similar resources and uses.

**Hotel and Motel Lodging Tax Fund**

To maintain and account for the accumulation and disbursement of hotel and motel tax collections.

**State Board of Building Standards Fund**

To account for funds from the three percent (3%) fees as required by Ohio Revised Code.

**MIAMI COUNTY, OHIO**

**Combining Statement Of Changes In Assets And Liabilities  
Agency Funds  
For the Year Ended December 31, 2004**

	Balance December 31, 2003	Additions	Deductions	Balance December 31, 2004
<b>Payroll Deductions Fund</b>				
Assets:				
Cash and Cash Equivalents	\$229,921	\$15,551,488	(\$15,541,386)	\$240,023
Total Assets	<u>\$229,921</u>	<u>\$15,551,488</u>	<u>(\$15,541,386)</u>	<u>\$240,023</u>
Liabilities:				
Due To Others	\$229,921	\$15,551,488	(\$15,541,386)	\$240,023
Total Liabilities	<u>\$229,921</u>	<u>\$15,551,488</u>	<u>(\$15,541,386)</u>	<u>\$240,023</u>
<b>Workers' Compensation Fund</b>				
Assets:				
Cash and Cash Equivalents	\$87,822	\$57,409	(\$93,362)	\$51,869
Total Assets	<u>\$87,822</u>	<u>\$57,409</u>	<u>(\$93,362)</u>	<u>\$51,869</u>
Liabilities:				
Due To Others	\$87,822	\$57,409	(\$93,362)	\$51,869
Total Liabilities	<u>\$87,822</u>	<u>\$57,409</u>	<u>(\$93,362)</u>	<u>\$51,869</u>
<b>Local Government Fund</b>				
Assets:				
Cash and Cash Equivalents	\$357	\$9,727,820	(\$9,727,820)	\$357
Total Assets	<u>\$357</u>	<u>\$9,727,820</u>	<u>(\$9,727,820)</u>	<u>\$357</u>
Liabilities:				
Due To Others	\$357	\$9,727,820	(\$9,727,820)	\$357
Total Liabilities	<u>\$357</u>	<u>\$9,727,820</u>	<u>(\$9,727,820)</u>	<u>\$357</u>
<b>Auto Registration Fund</b>				
Assets:				
Cash and Cash Equivalents	\$0	\$3,630,022	(\$3,630,022)	\$0
Total Assets	<u>\$0</u>	<u>\$3,630,022</u>	<u>(\$3,630,022)</u>	<u>\$0</u>
Liabilities:				
Intergovernmental Payables	\$0	\$3,630,022	(\$3,630,022)	\$0
Total Liabilities	<u>\$0</u>	<u>\$3,630,022</u>	<u>(\$3,630,022)</u>	<u>\$0</u>

(Continued)



**MIAMI COUNTY, OHIO**

**Combining Statement Of Changes In Assets And Liabilities  
Agency Funds  
For the Year Ended December 31, 2004**

	Balance December 31, 2003	Additions	Deductions	Balance December 31, 2004
<b>Township Gas Fund</b>				
Assets:				
Cash and Cash Equivalents	\$0	\$823,694	(\$823,694)	\$0
Total Assets	\$0	\$823,694	(\$823,694)	\$0
Liabilities:				
Other Accrued Liabilities	\$0	\$823,694	(\$823,694)	\$0
Total Liabilities	\$0	\$823,694	(\$823,694)	\$0
 <b>Cigarette Tax Fund</b>				
Assets:				
Cash and Cash Equivalents	\$12	\$3,790	(\$3,802)	\$0
Total Assets	\$12	\$3,790	(\$3,802)	\$0
Liabilities:				
Due To Others	\$12	\$3,790	(\$3,802)	\$0
Total Liabilities	\$12	\$3,790	(\$3,802)	\$0
 <b>Special Emergency Planning Fund</b>				
Assets:				
Cash and Cash Equivalents	\$41,886	\$26,243	(\$14,935)	\$53,194
Total Assets	\$41,886	\$26,243	(\$14,935)	\$53,194
Liabilities:				
Due To Others	\$41,886	\$26,243	(\$14,935)	\$53,194
Total Liabilities	\$41,886	\$26,243	(\$14,935)	\$53,194
 <b>Inheritance Tax Fund</b>				
Assets:				
Cash and Cash Equivalents	\$428,471	\$1,093,931	(\$1,410,904)	\$111,498
Investments	0	547,871	0	547,871
Total Assets	\$428,471	\$1,641,802	(\$1,410,904)	\$659,369
Liabilities:				
Due To Others	\$428,471	\$1,641,802	(\$1,410,904)	\$659,369
Total Liabilities	\$428,471	\$1,641,802	(\$1,410,904)	\$659,369

(Continued)

**MIAMI COUNTY, OHIO**

**Combining Statement Of Changes In Assets And Liabilities  
Agency Funds  
For the Year Ended December 31, 2004**

	Balance December 31, 2003	Additions	Deductions	Balance December 31, 2004
<b>Law Library Fund</b>				
Assets:				
Cash and Cash Equivalents	\$0	\$121,752	(\$121,752)	\$0
Total Assets	\$0	\$121,752	(\$121,752)	\$0
Liabilities:				
Due To Others	\$0	\$121,752	(\$121,752)	\$0
Total Liabilities	\$0	\$121,752	(\$121,752)	\$0
<b>Undivided Tax Settlement Fund</b>				
Assets:				
Cash and Cash Equivalents	\$1,105,776	\$92,957,616	(\$93,244,014)	\$819,378
Investments	1,420,132	909,806	(1,420,132)	909,806
Taxes Receivable	64,208,679	68,330,589	(64,208,679)	68,330,589
Total Assets	\$66,734,587	\$162,198,011	(\$158,872,825)	\$70,059,773
Liabilities:				
Due To Others	\$66,734,587	\$162,198,011	(\$158,872,825)	\$70,059,773
Total Liabilities	\$66,734,587	\$162,198,011	(\$158,872,825)	\$70,059,773
<b>Special Assessment Collection Fund</b>				
Assets:				
Cash and Cash Equivalents	\$0	\$1,013,374	(\$1,013,374)	\$0
Special Assessments Receivable	1,085,798	1,217,263	(1,085,798)	1,217,263
Total Assets	\$1,085,798	\$2,230,637	(\$2,099,172)	\$1,217,263
Liabilities:				
Due To Others	\$1,085,798	\$2,230,637	(\$2,099,172)	\$1,217,263
Total Liabilities	\$1,085,798	\$2,230,637	(\$2,099,172)	\$1,217,263
<b>Tri-County Board Fund</b>				
Assets:				
Cash and Cash Equivalents	\$1,107,225	\$9,320,477	(\$9,123,532)	\$1,304,170
Investments	1,421,994	1,448,102	(1,421,994)	1,448,102
Taxes Receivable	2,131,587	2,121,328	(2,131,587)	2,121,328
Total Assets	\$4,660,806	\$12,889,907	(\$12,677,113)	\$4,873,600
Liabilities:				
Due To Others	\$4,660,806	\$12,889,907	(\$12,677,113)	\$4,873,600
Total Liabilities	\$4,660,806	\$12,889,907	(\$12,677,113)	\$4,873,600

(Continued)

**MIAMI COUNTY, OHIO**

**Combining Statement Of Changes In Assets And Liabilities  
Agency Funds  
For the Year Ended December 31, 2004**

	Balance December 31, 2003	Additions	Deductions	Balance December 31, 2004
<b>County Court Agency Fund</b>				
Assets:				
Cash and Cash Equivalents	\$272,159	\$3,073,762	(\$3,071,050)	\$274,871
Accounts Receivable	806,928	761,562	(806,928)	761,562
Total Assets	<u>\$1,079,087</u>	<u>\$3,835,324</u>	<u>(\$3,877,978)</u>	<u>\$1,036,433</u>
Liabilities:				
Due To Others	<u>\$1,079,087</u>	<u>\$3,835,324</u>	<u>(\$3,877,978)</u>	<u>\$1,036,433</u>
Total Liabilities	<u>\$1,079,087</u>	<u>\$3,835,324</u>	<u>(\$3,877,978)</u>	<u>\$1,036,433</u>
<b>General County Agency Fund</b>				
Assets:				
Cash and Cash Equivalents	<u>\$1,400,198</u>	<u>\$19,932,617</u>	<u>(\$19,948,118)</u>	<u>\$1,384,697</u>
Total Assets	<u>\$1,400,198</u>	<u>\$19,932,617</u>	<u>(\$19,948,118)</u>	<u>\$1,384,697</u>
Liabilities:				
Due To Others	<u>\$1,400,198</u>	<u>\$19,932,617</u>	<u>(\$19,948,118)</u>	<u>\$1,384,697</u>
Total Liabilities	<u>\$1,400,198</u>	<u>\$19,932,617</u>	<u>(\$19,948,118)</u>	<u>\$1,384,697</u>
<b>Other County Agencies Fund</b>				
Assets:				
Cash and Cash Equivalents	\$2,044,259	\$4,582,099	(\$4,271,873)	\$2,354,485
Investments	2,625,417	2,614,327	(2,625,417)	2,614,327
Taxes Receivable	2,472,004	2,457,905	(2,472,004)	2,457,905
Total Assets	<u>\$7,141,680</u>	<u>\$9,654,331</u>	<u>(\$9,369,294)</u>	<u>\$7,426,717</u>
Liabilities:				
Due To Others	<u>\$7,141,680</u>	<u>\$9,654,331</u>	<u>(\$9,369,294)</u>	<u>\$7,426,717</u>
Total Liabilities	<u>\$7,141,680</u>	<u>\$9,654,331</u>	<u>(\$9,369,294)</u>	<u>\$7,426,717</u>
<b>Hotel and Motel Lodging Tax Fund</b>				
Assets:				
Cash and Cash Equivalents	<u>\$6,883</u>	<u>\$257,719</u>	<u>(\$255,466)</u>	<u>\$9,136</u>
Total Assets	<u>\$6,883</u>	<u>\$257,719</u>	<u>(\$255,466)</u>	<u>\$9,136</u>
Liabilities:				
Due To Others	<u>\$6,883</u>	<u>\$257,719</u>	<u>(\$255,466)</u>	<u>\$9,136</u>
Total Liabilities	<u>\$6,883</u>	<u>\$257,719</u>	<u>(\$255,466)</u>	<u>\$9,136</u>

(Continued)

**MIAMI COUNTY, OHIO**

**Combining Statement Of Changes In Assets And Liabilities  
Agency Funds  
For the Year Ended December 31, 2004**

	Balance December 31, 2003	Additions	Deductions	Balance December 31, 2004
<b>State Board of Building Standards Fund</b>				
Assets:				
Cash and Cash Equivalents	\$395	\$7,955	(\$8,058)	\$292
Total Assets	\$395	\$7,955	(\$8,058)	\$292
Liabilities:				
Due To Others	\$395	\$7,955	(\$8,058)	\$292
Total Liabilities	\$395	\$7,955	(\$8,058)	\$292
 <b>Total - All Agency Funds</b>				
Assets:				
Cash and Cash Equivalents	\$6,725,364	\$162,181,768	(\$162,303,162)	\$6,603,970
Investments	5,467,543	5,520,106	(5,467,543)	5,520,106
Taxes Receivable	68,812,270	72,909,822	(68,812,270)	72,909,822
Accounts Receivable	806,928	761,562	(806,928)	761,562
Special Assessments Receivable	1,085,798	1,217,263	(1,085,798)	1,217,263
Total Assets	\$82,897,903	\$242,590,521	(\$238,475,701)	\$87,012,723
Liabilities:				
Intergovernmental Payables	\$0	\$3,630,022	(\$3,630,022)	\$0
Due to Others	82,897,903	238,136,805	(234,021,985)	87,012,723
Other Accrued Liabilities	0	823,694	(823,694)	0
Total Liabilities	\$82,897,903	\$242,590,521	(\$238,475,701)	\$87,012,723

*CAPITAL ASSETS USED IN THE  
OPERATION OF GOVERNMENTAL FUNDS*

---



**MIAMI COUNTY, OHIO**

---

***Capital Assets Used in the Operation of Governmental Funds  
Schedule by Source  
December 31, 2004***

---

Capital Assets

Land	\$5,549,402
Construction in Progress	695,257
Buildings	35,285,165
Improvements Other Than Buildings	256,391
Machinery and Equipment	20,478,963
Infrastructure	<u>61,023,662</u>
Total Capital Assets	<u><u>\$123,288,840</u></u>

Investment in Capital Assets

General Fund	\$11,138,597
Special Revenue Funds	13,880,484
Capital Projects Funds	28,124,030
Capital Projects Funds Prior to 1989	4,391,950
Expendable Trust Funds	3,514
Enterprise Funds	20,665
Donations	2,243,294
Infrastructure Prior to 2002	<u>63,486,306</u>
Total Investment in Capital Assets	<u><u>\$123,288,840</u></u>

**MIAMI COUNTY, OHIO**

---

***Capital Assets Used in the Operation of Governmental Funds  
Schedule by Function and Activity  
December 31, 2004***

---

<u>Function and Category</u>	<u>Land</u>	<u>Construction In Progress</u>	<u>Buildings</u>
General Government	\$535,930	\$153,618	\$23,181,386
Judicial	0	0	44,796
Public Safety	24,921	541,639	7,662,557
Public Works	4,961,951	0	1,441,797
Health	26,600	0	1,320,258
Human Services	0	0	1,634,371
	<u>\$5,549,402</u>	<u>\$695,257</u>	<u>\$35,285,165</u>



**MIAMI COUNTY, OHIO**

---

---

<u>Improvements Other Than Buildings</u>	<u>Machinery and Equipment</u>	<u>Infrastructure</u>	<u>Total</u>
\$50,361	\$5,542,334	\$0	\$29,463,629
6,985	1,837,824	0	1,889,605
20,888	6,906,812	0	15,156,817
117,151	3,854,670	61,023,662	71,399,231
44,214	1,609,800	0	3,000,872
16,792	727,523	0	2,378,686
<u>\$256,391</u>	<u>\$20,478,963</u>	<u>\$61,023,662</u>	<u>\$123,288,840</u>

**MIAMI COUNTY, OHIO**

---

***Capital Assets Used in the Operation of Governmental Funds  
Schedule of Changes by Function and Activity  
For Year Ended December 31, 2004***

---

Function	December 31, 2003	Additions	Deletions	December 31, 2004
General Government	\$29,178,533	\$8,878,200	(\$8,593,104)	\$29,463,629
Judicial	1,882,265	38,516	(31,176)	1,889,605
Public Safety	14,575,571	1,546,780	(965,534)	15,156,817
Public Works	69,409,602	2,395,161	(405,532)	71,399,231
Health	2,874,044	222,427	(95,599)	3,000,872
Human Services	2,301,351	99,941	(22,606)	2,378,686
Total Capital Assets	<u>\$120,221,366</u>	<u>\$13,181,025</u>	<u>(\$10,113,551)</u>	<u>\$123,288,840</u>

# *STATISTICAL SECTION*

---

---



*STATISTICAL TABLES*

---

***T**HE FOLLOWING UNAUDITED STATISTICAL TABLES REFLECT SOCIAL AND ECONOMIC DATA, FINANCIAL TRENDS AND FISCAL CAPACITY OF THE COUNTY.*

**MIAMI COUNTY, OHIO**

---

**GENERAL GOVERNMENT EXPENDITURES BY FUNCTION (1)  
LAST TEN YEARS**

<b>Year</b>	<b>Public Safety</b>	<b>Health</b>	<b>Human Services</b>	<b>Conservation and Recreation</b>	<b>Public Works</b>	<b>General Government</b>	<b>Capital Outlay</b>	<b>Debt Service</b>	<b>Total</b>
1995	\$7,531,779	\$5,401,501	\$7,747,692	\$235,373	\$5,928,749	\$8,752,067	\$463,591	\$603,872	\$36,664,624
1996	8,320,238	5,943,319	8,263,278	369,178	6,588,323	12,036,333	2,905,864	458,726	44,885,259
1997	9,462,885	7,169,084	8,362,245	432,445	5,237,636	14,098,604	1,613,377	1,336,711	47,712,987
1998	9,684,216	7,615,506	8,874,294	381,567	4,629,809	12,528,423	5,336,673	603,991	49,654,479
1999	12,110,563	7,887,381	9,769,876	433,475	6,050,301	11,505,735	5,965,947	757,909	54,481,187
2000	12,777,469	8,090,945	10,510,608	456,791	6,740,686	12,005,531	3,670,812	665,743	54,918,585
2001	13,864,439	9,019,913	11,851,536	541,255	9,012,046	12,270,362	1,212,123	635,523	58,407,197
2002	15,722,849	9,302,110	12,638,760	355,069	6,443,600	12,700,844	1,478,081	579,586	59,220,899
2003	15,520,763	9,913,898	12,473,435	449,267	6,088,117	13,012,999	1,126,747	846,302	59,431,528
2004	16,396,824	10,630,088	12,666,216	484,357	7,528,033	13,167,295	636,854	879,002	62,388,669

(1) Includes General, Special Revenue, Debt Service and Capital Projects Funds.

**MIAMI COUNTY, OHIO**

---

**GENERAL GOVERNMENT REVENUES BY SOURCE (1)  
LAST TEN YEARS**

<b>Year</b>	<b>Taxes</b>	<b>Inter-Governmental Revenues</b>	<b>Charges for Services</b>	<b>Licenses and Permits</b>	<b>Investment Earnings</b>	<b>Fines and Forfeitures</b>	<b>All Other</b>	<b>Total</b>
1995	\$18,763,125	\$15,297,660	\$5,445,092	\$280,862	\$2,290,426	\$1,259,167	\$540,009	\$43,876,341
1996	14,998,488	17,432,597	6,285,360	369,822	2,319,702	1,111,138	556,870	43,073,977
1997	16,729,071	16,119,137	7,029,746	358,569	2,260,725	1,163,930	725,306	44,386,484
1998	20,494,122	16,341,541	7,654,418	361,256	2,738,220	1,263,668	904,427	49,757,652
1999	20,655,696	24,941,216	9,773,677	298,453	2,656,381	1,342,157	632,620	60,300,200
2000	19,207,021	20,043,666	10,098,425	398,808	2,928,967	1,433,064	789,341	54,899,292
2001	20,925,983	23,158,300	10,699,575	402,422	3,075,942	1,560,521	831,977	60,654,720
2002	20,027,419	21,970,913	11,019,752	431,354	1,569,448	1,491,766	900,747	57,411,399
2003	21,310,935	21,046,540	12,633,018	482,060	953,412	1,598,345	1,162,948	59,187,258
2004	22,332,039	23,099,591	12,544,201	536,189	778,890	1,324,446	1,028,869	61,644,225

(1) Includes General, Special Revenue, Debt Service and Capital Projects Funds.

## *MIAMI COUNTY, OHIO*

### *PROPERTY TAX LEVIES AND COLLECTIONS (1) LAST TEN YEARS*

<u>Collection Year</u>	<u>Total Tax Levy</u>	<u>Current Tax Collections</u>	<u>Delinquent Tax Collections</u>	<u>Total Tax Collections</u>	<u>Percent of Total Tax Collections to Tax Levy</u>	<u>Accumulated Outstanding Delinquent Taxes</u>	<u>Percentage of Accumulated Delinquent Taxes to Total Tax Levy</u>
1995	\$11,883,160	\$11,698,119	\$344,487	\$12,042,606	101.34%	\$351,371	2.96%
1996 (2)	7,152,109	6,929,900	110,919	7,040,819	98.44%	227,118	3.18%
1997 (3)	9,009,663	8,862,717	217,199	9,079,916	100.78%	311,398	3.46%
1998 (4)	12,476,804	12,213,126	307,680	12,520,806	100.35%	416,397	3.34%
1999	12,603,784	12,378,906	311,164	12,690,070	100.68%	354,016	2.81%
2000	13,316,706	13,036,386	375,070	13,411,456	100.71%	483,466	3.63%
2001 (5)	15,581,179	15,125,899	317,245	15,443,144	99.11%	643,531	4.13%
2002 (6)	15,202,556	14,796,078	401,435	15,197,513	99.97%	1,002,935	6.60%
2003 (7)	16,975,455	16,519,610	534,654	17,054,264	100.46%	1,126,301	6.63%
2004	16,886,055	16,516,878	535,588	17,052,466	100.99%	1,028,662	6.09%

(1) Includes General Fund and Special Revenue Funds

(2) The 0.00 mill of a 4.00 mill levied for Riverside School.

(3) 1.00 mill of a 4.00 mill levy for Riverside School.

(4) 4.00 mill levied replaced/reduced to 2.8 mill for Riverside School.

(5) 1.70 mill replacement levy for Riverside School.

(6) a. .50 mill replacement levy with .60 increase for 1.10 mills for Park District

b. 1.8 mills levied for Riverside School

c. Revaluation for tax year 2001

d. .40 mill replacement levy for Health District

(7) .60 mill replacement levy for Tri-County Board.

Source: Miami County Auditor



**MIAMI COUNTY, OHIO**

**ASSESSED VALUATIONS AND ESTIMATED TRUE VALUES  
OF TAXABLE PROPERTY  
LAST TEN YEARS  
(in Thousands)**

<b>Tax Year</b>	<b>Real Property</b>		<b>Public Utility Personal</b>		<b>Tangible Personal Property</b>		<b>Total</b>		<b>Assessed Value as a Percent of Actual Value</b>
	<b>Assessed</b>	<b>Actual</b>	<b>Assessed</b>	<b>Actual</b>	<b>Assessed</b>	<b>Actual</b>	<b>Assessed</b>	<b>Actual</b>	
1995	\$1,176,664	\$3,361,897	\$883,267	\$2,523,620	\$262,823	\$1,051,292	\$2,322,754	\$6,936,809	33.48%
1996	1,203,430	3,438,371	893,202	2,552,006	271,704	1,086,816	2,368,336	7,077,193	33.46%
1997	1,241,376	3,546,789	95,128	271,794	267,887	1,071,548	1,604,391	4,890,131	32.81%
1998	1,396,617	3,990,334	96,856	276,731	287,432	1,149,728	1,780,905	5,416,794	32.88%
1999	1,429,311	4,083,746	96,209	274,883	290,738	1,162,952	1,816,258	5,521,581	32.89%
2000	1,464,115	4,183,186	91,699	261,997	304,869	1,219,476	1,860,683	5,664,659	32.85%
2001	1,314,415	3,755,471	64,244	183,554	309,861	1,239,444	1,688,520	5,178,470	32.61%
2002	1,635,372	4,672,491	66,096	188,846	317,695	1,270,780	2,019,163	6,132,117	32.93%
2003	1,365,818	3,902,337	64,630	184,657	305,664	1,222,656	1,736,112	5,309,650	32.70%
2004	1,773,597	5,067,420	63,432	181,234	281,330	1,125,320	2,118,359	6,373,974	33.23%

Source: Miami County Auditor

## MIAMI COUNTY, OHIO

### PROPERTY TAX RATES ALL DIRECT AND OVERLAPPING GOVERNMENTS (PER \$1,000 OF ASSESSED VALUATIONS) LAST TEN YEARS

<b>COUNTY UNITS</b>	<b>1995</b>	<b>1996</b>	<b>1997</b>	<b>1998</b>	<b>1999</b>	<b>2000</b>	<b>2001</b>	<b>2002</b>	<b>2003</b>	<b>2004</b>
General Fund	2.40	2.40	2.40	2.40	2.40	2.40	2.40	2.40	2.40	2.40
Park Levy	0.50	0.50	0.50	0.50	0.50	0.50	1.10	1.10	1.10	1.10
Special Bridge	0.80	0.80	0.80	0.80	0.80	0.80	0.80	0.80	0.80	0.80
Riverside School	1.70	2.70	4.50	4.50	4.50	4.50	3.50	4.20	4.20	4.20
Tri-County Mental Health	0.60	0.60	0.60	0.60	0.60	0.60	0.60	0.60	0.60	0.60
Conservancy	0.02	0.03	0.02	0.02	0.01	0.03	0.03	0.03	0.03	0.01
Total County Rate	6.02	7.03	8.82	8.82	8.81	8.83	8.43	9.13	9.13	9.11
<b>SCHOOL DISTRICTS</b>										
Bethel	50.45	50.45	50.45	50.45	55.95	55.90	55.49	55.29	55.11	54.81
Bradford	25.90	25.90	25.90	31.10	30.11	30.20	30.09	30.02	30.02	29.87
Covington	36.40	36.26	36.26	35.42	35.42	35.40	35.26	35.24	35.18	34.90
Franklin-Monroe	32.15	32.15	32.15	32.15	32.15	32.15	32.15	32.15	32.15	32.15
Miami East	42.50	41.50	41.50	41.50	41.50	41.50	41.50	41.50	42.80	45.80
Milton-Union	55.90	55.90	55.90	55.90	55.90	55.90	55.90	55.90	66.80	66.80
Newton	38.14	35.80	38.36	37.80	37.80	37.80	37.80	39.60	39.60	39.60
Northmont	59.18	59.08	59.03	58.93	58.85	58.83	58.80	58.35	64.15	64.15
Piqua	41.30	40.70	40.70	40.62	40.56	40.60	40.50	40.42	45.31	45.05
Troy	44.10	50.10	50.10	50.10	54.60	54.60	54.60	54.60	54.60	56.59
Tipp City	43.20	43.28	43.20	43.20	43.20	47.86	47.50	47.30	47.30	47.60
Tecumseh	46.67	46.18	45.63	44.40	44.40	44.10	44.10	42.60	48.05	46.10
<b>JOINT VOCATIONAL SCHOOL DISTRICTS</b>										
Montgomery County	2.58	2.58	2.58	2.58	2.58	2.58	2.58	2.58	2.58	2.58
Springfield/Clark County	3.00	3.00	3.00	3.00	3.00	3.00	3.00	3.00	3.00	3.00
Upper Valley	4.90	4.90	4.90	4.90	4.90	4.90	4.90	4.90	5.46	5.45

(Continued)

## MIAMI COUNTY, OHIO

**PROPERTY TAX RATES ALL DIRECT AND OVERLAPPING GOVERNMENTS  
(PER \$1,000 OF ASSESSED VALUATIONS)  
LAST TEN YEARS**

	1995	1996	1997	1998	1999	2000	2001	2002	2003	2004
<b>CORPORATIONS</b>										
Bradford	12.75	12.50	12.50	12.50	12.50	12.50	12.50	12.50	12.50	12.50
Casstown	5.35	5.35	5.35	5.35	5.35	5.35	5.35	5.35	5.35	5.35
Covington	6.90	6.90	6.90	6.90	6.90	6.90	6.90	6.90	6.90	6.90
Fletcher	2.70	2.70	2.70	3.70	3.70	4.70	4.70	4.70	4.70	4.70
Huber Heights	10.29	10.26	10.26	10.24	10.19	10.18	10.14	10.12	10.09	10.08
Laura	3.40	3.40	3.40	3.40	3.40	3.40	3.40	3.40	3.40	3.40
Ludlow Falls	3.40	3.40	3.40	3.40	3.40	3.40	3.40	3.40	3.40	3.40
Piqua	4.40	4.42	4.42	4.43	4.41	4.45	4.45	4.43	4.43	4.40
Pleasant Hill	5.65	5.65	5.65	5.65	5.65	5.65	6.15	4.40	4.40	1.40
Potsdam	3.40	3.40	3.40	3.40	3.40	3.40	3.40	3.40	3.40	3.40
Tipp City	1.40	1.40	1.40	1.40	1.40	1.40	1.40	1.40	1.40	1.40
Troy	3.18	3.24	3.26	3.29	3.25	3.25	3.26	3.22	3.22	3.24
Union	0.00	13.11	13.11	16.03	16.03	16.03	16.03	16.03	16.03	18.53
West Milton	6.40	6.40	6.40	6.40	6.40	6.40	6.40	6.40	6.40	6.40
<b>TOWNSHIPS</b>										
Bethel	5.80	5.80	5.80	5.80	6.10	5.60	5.60	5.60	9.40	9.40
Brown	3.10	3.10	3.10	4.10	4.10	5.10	5.10	5.10	5.10	5.10
Concord	2.30	2.30	2.30	2.30	2.30	2.30	3.30	3.30	3.80	3.80
Elizabeth	1.10	1.10	1.10	1.10	1.10	1.10	1.10	1.10	1.10	1.10
Lostcreek	3.10	3.10	3.10	3.10	3.10	3.10	3.10	3.10	3.10	3.60
Monroe	3.40	3.40	3.40	3.40	3.40	3.40	3.40	3.40	3.40	3.40
Newberry	4.50	4.50	4.50	4.50	4.50	4.50	4.50	4.50	4.50	4.50
Newton	1.80	1.80	1.80	1.80	1.80	1.80	1.80	1.80	1.80	1.80
Springcreek	1.80	1.80	1.80	1.80	1.80	2.30	2.30	2.30	2.30	2.30
Staunton	2.10	2.10	2.10	2.10	2.10	6.10	6.10	6.10	6.10	6.10
Union	2.70	2.70	4.20	4.20	4.20	4.20	4.20	4.20	4.20	4.20
Washington	1.60	1.60	1.60	1.60	1.60	1.60	1.60	1.60	1.60	1.60

**MIAMI COUNTY, OHIO**

---

**COMPUTATION OF LEGAL DEBT MARGIN  
DECEMBER 31, 2004**

	<b>Total Debt</b>	<b>Unvoted Debt</b>
Net Assessed Valuation	\$2,118,359,500	\$2,118,359,500
Legal Debt Limitation (%) (1)	2.43%	1.00%
Legal Debt Limitation (\$) (1)	51,458,988	21,183,595
Applicable County Debt Outstanding (2)	7,050,000	7,050,000
Less Applicable Debt Service Fund Amounts (3)	(87,153)	(87,153)
Net Indebtedness Subject To Limitation	6,962,847	6,962,847
Legal Debt Margin	\$44,496,141	\$14,220,748

(1) Direct Debt Limitation Based Upon Section 133, The Uniform Bond Act of the Ohio Revised Code.

(2) County Debt Outstanding Does Not Include Self-Supporting General Obligation Bonds.

(3) Does Not Include Special Assessment Debt Fund Balance.

**MIAMI COUNTY, OHIO**

---

**RATIO OF NET GENERAL OBLIGATION BONDED DEBT TO ASSESSED VALUE  
AND NET GENERAL OBLIGATION BONDED DEBT PER CAPITA  
LAST TEN YEARS**

<b>Year</b>	<b>Population (1)</b>	<b>Assessed Value (2)</b>	<b>Gross Bonded Debt (3)</b>	<b>Debt Service Funds Available (4)</b>	<b>Net Bonded Debt</b>	<b>Ratio of Net Bonded Debt to Assessed Valuation</b>	<b>Net Bonded Debt Per Capita</b>
1995	93,182	\$1,527,813,829	\$3,190,000	\$105,195	\$3,084,805	0.20%	\$33.11
1996	93,182	1,564,454,300	3,045,000	146,253	2,898,747	0.19%	31.11
1997	93,182	1,604,391,200	3,435,000	141,261	3,293,739	0.21%	35.35
1998	93,182	1,780,905,460	3,180,000	79,472	3,100,528	0.17%	33.27
1999	93,182	1,816,258,250	2,915,000	153,007	2,761,993	0.15%	29.64
2000	98,868	1,860,683,820	2,650,000	68,244	2,581,756	0.14%	26.11
2001	98,868	1,989,108,790	2,385,000	61,043	2,323,957	0.12%	23.51
2002	98,868	2,019,162,310	8,020,000	394,085	7,625,915	0.38%	77.13
2003	98,868	2,038,528,940	7,560,000	78,154	7,481,846	0.37%	75.68
2004	98,868	2,118,359,500	7,050,000	87,153	6,962,847	0.33%	70.43

(1) Source: U.S. Bureau of Census, Federal 1990/2000 Census

(2) Source: Miami County Auditor

(3) Does not include Self-Supporting General Obligation Debt

(4) Does not include Special Assessment Debt Fund Balance

**MIAMI COUNTY, OHIO**

---

**RATIO OF ANNUAL DEBT SERVICE EXPENDITURES FOR GENERAL OBLIGATION  
BONDED DEBT TO TOTAL GENERAL GOVERNMENT EXPENDITURES  
LAST TEN YEARS**

<u>Year</u>	<u>Debt Principal</u>	<u>Debt Interest</u>	<u>Total Debt Service</u>	<u>Total General Government Expenditures (1)</u>	<u>Ratio of Total Debt Service To Total General Government Expenditures</u>
1995	\$255,000	\$250,271	\$505,271	\$36,664,624	1.38%
1996	145,000	233,400	378,400	44,885,259	0.84%
1997	1,020,000	301,194	1,321,194	47,712,987	2.77%
1998	255,000	156,670	411,670	49,654,479	0.83%
1999	265,000	140,379	405,379	54,481,187	0.74%
2000	265,000	114,468	379,468	54,918,585	0.69%
2001	265,000	118,119	383,119	58,407,197	0.66%
2002	270,000	106,989	376,989	59,220,899	0.64%
2003	460,000	362,337	822,337	59,431,528	1.38%
2004	510,000	309,229	819,229	62,388,669	1.31%

(1) Includes General, Special Revenue, Debt Service and Capital Projects Funds.

**MIAMI COUNTY, OHIO**

---

**COMPUTATION OF ALL DIRECT AND OVERLAPPING  
GENERAL OBLIGATION DEBT  
DECEMBER 31, 2004**

<u>Jurisdiction</u>	<u>General Obligation Debt</u>	<u>Percentage Applicable To Miami County (1)</u>	<u>Amount Applicable To Miami County</u>
<b>Direct:</b>			
Miami County (2)	\$7,050,000	100.00%	\$7,050,000
<b>Overlapping Subdivisions:</b>			
Corporations wholly within County	16,465,000	100.00%	16,465,000
Corporations with Overlapping	6,836,908	1.58%	<u>108,228</u>
		Sub-Total	<u>16,573,228</u>
		Grand Total	<u><u>\$23,623,228</u></u>

(1) Percentages determined by dividing the assessed valuation of the Miami County political subdivision by the total assessed valuation which includes all overlapping.

(2) Includes only Non Self-Supporting General Obligation Bonds

Source: Miami County Auditor  
Darke County Auditor  
Champaign County Auditor

**MIAMI COUNTY, OHIO**

---

**DEMOGRAPHIC STATISTICS  
LAST TEN YEARS**

<u>Year</u>	<u>Population (1)</u>	<u>School Enrollment (2)</u>	<u>Unemployment Rate Metropolitan Area (3)</u>
1995	93,182	17,989	3.7%
1996	93,182	18,147	4.2%
1997	93,182	19,163	4.3%
1998	93,182	19,210	3.6%
1999	93,182	18,954	4.3%
2000	98,868	19,084	3.3%
2001	98,868	18,718	4.3%
2002	98,868	18,717	5.3%
2003	98,868	19,829	5.3%
2004	98,868	18,240	5.7%

(1) Source: U.S. Bureau of Census of Population - Federal 1990/2000 Census

(2) Source: Ohio Department of Education, Division of Computer Services and Statistical Reports.

(3) Source: Ohio Bureau of Employment Services



**MIAMI COUNTY, OHIO**

---

**PROPERTY VALUE AND CONSTRUCTION PERMITS  
LAST TEN YEARS**

<b>Year</b>	<b>Residential (1)</b>		<b>Commercial (1)</b>	
	<b>Number of Permits</b>	<b>Property Value</b>	<b>Number of Permits</b>	<b>Property Value</b>
1995	282	\$35,349,420	101	\$29,733,116
1996	343	46,289,660	174	78,335,034
1997	294	41,903,181	176	68,935,911
1998	296	44,200,612	174	63,729,079
1999	208	35,937,234	177	27,778,159
2000	298	49,447,065	220	51,245,111
2001	213	39,405,496	180	30,399,501
2002	255	42,691,120	123	34,451,962
2003	220	39,855,245	123	29,965,676
2004	272	55,065,264	158	28,152,391

(1) Source: Miami County Auditor's Office and State Board of Building Standards.

**MIAMI COUNTY, OHIO**

---

**PRINCIPAL TAXPAYERS (PROPERTY TAX)  
DECEMBER 31, 2004**

<u>Taxpayer</u>	<u>Type of Business</u>	<u>2004 Assessed Valuation (Tax Duplicate)</u>	<u>Total Assessed Valuation</u>
1. MT Picture Display	Manufacturing	\$41,897,830	1.98%
2. Dayton Power & Light	Utilities	37,393,500	1.77%
3. American Honda Motor	Manufacturing	24,956,150	1.18%
4. Meijers Inc.	Retail	21,828,020	1.03%
5. Illinois Tool Works, Inc.	Manufacturing	14,595,730	0.69%
6. Goodrich Corporation	Manufacturing	13,805,060	0.65%
7. F & P of America	Manufacturing	9,872,960	0.47%
8. Jackson Tube Services	Manufacturing	9,171,400	0.43%
9. Midamco	Manufacturing	8,849,340	0.42%
10. Evenflo Company Inc.	Manufacturing	8,650,400	0.41%
Sub-Total		<u>191,020,390</u>	9.03%
All Others		<u>1,927,339,110</u>	<u>90.97%</u>
Total		<u><u>\$2,118,359,500</u></u>	<u><u>100.00%</u></u>

Source: Miami County Auditor

**MIAMI COUNTY, OHIO**

---

**PRINCIPAL EMPLOYERS  
DECEMBER 31, 2004**

<u>Employer</u>	<u>Number of Employees</u>
1. Upper Valley Medical Center	1,800
2. MT Picture Display Corp.	829
3. Miami County	1,021
4. Meijer Distribution	884
5. ITW/Hobart Company	651
6. Goodrich Corporation	698
7. ITW/Hobart Brothers Company	539
8. F & P America Mfg. Inc.	600
9. Troy City School District	486
10. Evenflo Juvenile Division	311

Source: Miami County Auditor

**MIAMI COUNTY, OHIO**

---

**SALARIES OF PRINCIPAL OFFICIALS  
DECEMBER 31, 2004**

<b>Elected Officials</b>	
<b>Office</b>	<b>2004 Salaries</b>
Board of Commissioners (3)	\$59,510
Auditor	72,606
Prosecuting Attorney	104,930
Clerk of Courts	55,544
Sheriff	76,652
Recorder	51,902
Treasurer	55,544
Engineer	86,328
Coroner	46,439

Source: Miami County Auditor

**MIAMI COUNTY, OHIO**

---

**SURETY BOND COVERAGE - VARIOUS OFFICIALS  
DECEMBER 31, 2004**

<u>Office</u>	<u>Bond Coverage</u>
Board of Commissioners (3)	\$20,000
Auditor	20,000
Prosecuting Attorney	108,448
Clerk of Courts	40,000
Sheriff	62,571
Recorder	10,000
Treasurer	50,000
Engineer	10,000
Coroner	10,000
Probate Court Judge	40,000
Park District (3)	5,000
Department of Job and Family Services Director	5,000
Children Services Director	20,000

Source: Miami County Auditor





**Auditor of State  
Betty Montgomery**

88 East Broad Street  
P.O. Box 1140  
Columbus, Ohio 43216-1140  
Telephone 614-466-4514  
800-282-0370  
Facsimile 614-466-4490

## **FINANCIAL CONDITION**

### **MIAMI COUNTY**

#### **CLERK'S CERTIFICATION**

**This is a true and correct copy of the report which is required to be filed in the Office of the Auditor of State pursuant to Section 117.26, Revised Code, and which is filed in Columbus, Ohio.**

*Susan Babbitt*

**CLERK OF THE BUREAU**

**CERTIFIED  
SEPTEMBER 27, 2005**