

# ***REGIONAL INCOME TAX AGENCY***

*Comprehensive Annual Financial Report  
For the Years Ended December 31, 2006 and 2005*

Issued by the Finance Department  
Christy J. Price,  
Deputy Executive Director, Chief Financial Officer





Mary Taylor, CPA  
Auditor of State

Board of Trustees  
Regional Income Tax Agency  
10107 Brecksville Road  
Brecksville, Ohio 44141-3275

We have reviewed the *Independent Auditors' Report* of the Regional Income Tax Agency, Cuyahoga County, prepared by Ciuni & Panichi, Inc., for the audit period January 1, 2006 through December 31, 2006. Based upon this review, we have accepted these reports in lieu of the audit required by Section 117.11, Revised Code. The Auditor of State did not audit the accompanying financial statements and, accordingly, we are unable to express, and do not express an opinion on them.

Our review was made in reference to the applicable sections of legislative criteria, as reflected by the Ohio Constitution, and the Revised Code, policies, procedures and guidelines of the Auditor of State, regulations and grant requirements. The Regional Income Tax Agency is responsible for compliance with these laws and regulations.

*Mary Taylor*

Mary Taylor, CPA  
Auditor of State

July 17, 2007

**This Page is Intentionally Left Blank.**

**PREPARED BY THE FINANCE DEPARTMENT**

**Christy J. Price – Chief Financial Officer**  
**Lori A. Starcher – Assistant Director of Finance**  
**Kimberly L. Schindler - Accountant**  
**Sandra M. Majkrzak - Accounting Clerk**

# Regional Income Tax Agency

Comprehensive Annual Financial Report  
For the Years Ended December 31, 2006 and 2005

Table Of Contents	PAGE
-------------------	------

---

## INTRODUCTORY SECTION

Letter of Transmittal – Deputy Executive Director/Chief Financial Officer .....	iii
Officers and Board Members .....	vii
Management Officials.....	viii
Organization Chart .....	ix
GFOA Certificate .....	x

## FINANCIAL SECTION

Independent Auditors’ Report.....	1
Management’s Discussion and Analysis.....	3
Basic Financial Statements:	
Statements of Net Assets .....	13
Statements of Revenues, Expenses and Changes in Net Assets .....	14
Statements of Cash Flows.....	15
Statements of Fiduciary Net Assets .....	17
Notes to Financial Statements .....	18
Supplementary Information:	
Schedule of Changes in Fiduciary Net Assets.....	35
Schedule of Revenues and Expenses – Budget and Actual (GAAP Basis).....	36
Notes to Supplementary Information .....	37

## STATISTICAL SECTION (UNAUDITED)

Changes in Net Assets – Last Four Years .....	39
Revenues by Type – Last Ten Years .....	40
Municipal Income Tax Receipts – Last Ten Fiscal Years.....	41
Operating Expenses by Type – Last Ten Years .....	45
Operating Indicators – Last Ten Fiscal Years .....	46
Membership as of December 31, 2006 Table of Census Data.....	47
Municipal Income Tax Rates, Credits and Limits – Last Ten Fiscal Years .....	52
Ratio of Outstanding Debt to Members Tax Collections and Population – Last Seven Fiscal Years .....	65

## **Introductory Section**



10107 Brecksville Road • Brecksville, Ohio 44141-3275  
TDD (440) 526-5332 1-800-860-RITA (440) 526-0900  
Fax: (440) 526-8013

June 15, 2007

The Board of Trustees  
of the Regional Income Tax Agency  
and Member Municipalities

The Regional Income Tax Agency (R.I.T.A. or the Agency) issues a Comprehensive Annual Financial Report (CAFR) in response to Ohio law ((Ohio Administrative Code Section 117-2-03(B)). This regulation requires the Agency's audited financial reports, prepared on a GAAP (Generally Accepted Accounting Principles) basis, to be filed with the Auditor of State within six months of the close of each fiscal year. This report was published to fulfill that requirement for the fiscal year ended December 31, 2006.

R.I.T.A.'s management assumes full responsibility for the completeness and reliability of the information contained in this report, based upon a comprehensive framework of internal control that is maintained for this purpose. As the cost of internal control should not exceed the benefit, the objective is to provide reasonable, rather than absolute, assurance that the financial statements are free of any material misstatements. To the best of our knowledge and belief the enclosed information is accurate in all material respects and is reported in a manner designed to present fairly the financial position and results of operations of the Agency. All disclosures necessary to enable the reader to gain an understanding of the Agency's financial activities have been included.

Ciuni & Panichi, Inc. (Certified Public Accountants and Business Advisors), have issued an unqualified opinion on the Regional Income Tax Agency's financial statements for the year ended December 31, 2006. The Independent Auditors' Report is located at the front of the financial section of this report.

Management's discussion and analysis (MD&A) immediately follows the independent auditors' report and provides a narrative introduction, overview and analysis of the basic financial statements. The information contained in the MD&A complements this letter of transmittal and should be read in conjunction with the transmittal for a complete comprehension of the results of the 2006 operations.

### ***Profile of the Government***

The Regional Income Tax Agency was established in 1971 to collect and distribute municipal income taxes. The Agency was created by the members of a Regional Council of Governments (RCOG) under Section 167 of the Ohio Revised Code and is subject to Ohio law in areas that include investments, purchasing and employee benefits. R.I.T.A. is guided by a nine member Board of Trustees, elected by the members of the RCOG for three year terms. The Trustees appoint the Executive Director who is responsible for the operations of the Agency. The membership has grown from 38 municipalities at inception to over 135 members today.



For financial reporting purposes, the Regional Income Tax Agency's basic financial statements include the two funds for which the Agency is financially responsible. Following the GASB (Governmental Accounting Standards Board) definition of financial accountability there are no other entities that required incorporation into the financial statements.

### ***Budgetary Process***

Although not required under the Ohio Revised Code, an annual operating budget is adopted for management purposes in accordance with the by-laws of the Regional Income Tax Agency's charter. R.I.T.A.'s budget is prepared on the accrual basis, by department, for personal services and other expenses; the debt service is budgeted for the Agency as a whole. The Board of Trustees approves the budget and authorizes the Executive Director to expend the funds per purchasing restrictions.

The Executive Director has the authority to approve most expenses for goods and services under \$7,500. The Board's Finance Committee approves all purchases \$7,500 to \$14,999 and any legal costs regardless of amount. Finally, all expenditures of \$15,000 and greater must be authorized by the Board of Trustees. The Trustees must also authorize any budget reallocation between departments or by expense type or for an increase in the total budget. The Board approved one budget amendment in 2006.

## **Factors Affecting Financial Condition**

### ***Local Economies***

The Agency's membership extends across 42 counties in the State of Ohio. The municipalities' local economies range from situations of robust growth to circumstances of economic downturn. Overall, the membership appears to have a stable economic environment as the average collection growth for established members with no changes in rates or credits was 4.3% for 2006.

The Agency total collections have grown substantially over the past few years. In 2004 collections were approximately \$493 million; by the end of 2006 the number had grown to \$622 million. Current projections show that R.I.T.A. will likely exceed three-quarters of a billion dollars in collections in 2008. In conjunction with the rising tax revenues, the Agency's average net cost percentage has decreased from 2.49% in 2004 to 1.84% in 2006. This means that, on average, R.I.T.A.'s 2006 cost to the members was less than 2 cents per dollar collected. Low costs help keep the Regional Income Tax Agency's services attractive to its members which in turn maintains the Agency's solid economic footing.

## **Relevant Financial Policies**

### ***Internal Control***

As briefly discussed above, the Agency's management is responsible for establishing and maintaining an internal control structure designed to ensure that R.I.T.A.'s assets are protected from loss, theft or misuse. The internal control structure is designed to provide reasonable, but not absolute, assurance that these objectives are met. The concept of reasonable assurance recognizes that: 1) the cost of a control should not exceed the benefits likely to be derived; and 2) the valuation of costs and benefits requires estimates and judgments by management. All Agency internal controls are designed within the above framework. Accordingly, it is believed that the system of internal controls is adequate to safeguard assets and provide reasonable assurance of proper recording of transactions.

### ***Basis of Accounting***

The Regional Income Tax Agency implemented GASB Statement 34, “Basic Financial Statements and Management’s Discussion and Analysis for State and Local Governments” in 2004. GASB 34 creates basic financial statements for reporting the Agency’s financial activities. As such, the financial statements present one proprietary fund and one fiduciary fund.

### ***Debt Administration***

The Agency is restricted in its ability to issue debt and consequently, has entered into such agreements sparingly. However, R.I.T.A. did assume debt several years ago and the funds were used to advance the Agency’s effort to update its technology (see Footnote number seven for further information). The assets obtained with the proceeds of the debt are depreciated over the useful lives of the items and the related expense is recognized in the proper accounting periods. Furthermore, the debt repayment schedules were structured in a manner to best match the depreciation with the principal payments. Future debt issuances are not expected to be needed as continuous updating of the Agency’s technology is planned.

### ***Cash Management***

Prior to distribution all Agency cash is pooled for investment purposes to provide a maximum yield while protecting principal through conservative investment choices. The Agency’s investment policy designates the type of investments that can be made and only permits investments which are in compliance with the Ohio Revised Code. Protection of the Agency’s deposits is provided by the Federal Deposit Insurance Corporation (FDIC), eligible instruments pledged by the financial institution as security for repayment or a single collateral pool established by the financial institution to secure the repayment of all public monies deposited with the institution. The Agency primarily invests in short-term, liquid instruments; there is also a core of funds available for investments with terms not to exceed one year.

### ***Risk Management***

R.I.T.A. is exposed to various risks of loss including theft, damage to or destruction of assets, errors and omissions, torts and legal judgments and employee injuries. The Regional Income Tax Agency mitigates these risks by maintaining comprehensive general liability insurance, an overall umbrella policy as well as coverage for business interruption and property losses. The Agency provides health, dental and vision insurance to its employees through two standard premium-based plans and obtains coverage through the State of Ohio Worker’s Compensation program.

### ***Major Initiatives***

During the year, the Agency further enhanced its eBusiness functionalities. The systems are very user-friendly and as a result, R.I.T.A. experienced an outstanding growth in system utilization over prior periods. The eBusiness systems increase processing efficiencies, lower operating costs and improve services for taxpayers. Also implemented in 2006 was the updated Data Entry Interface portion of the new tax system (RITAX). The system presents a graphical interface that most computer users are accustomed to using. As a result, the new system is easier to learn and use. The RITAX system will continue to be rolled out in stages which has proven to be the most efficient and effective method for the Agency.

For several years R.I.T.A. made a dedicated effort to change a Federal Law that would authorize the IRS to release taxpayer information to Regional Councils of Governments. Previously, the regulations limited the data sharing to municipalities with populations in excess of 250,000. The Agency's initiative successfully culminated in 2006 as the legislation passed in the House of Representatives on December 8<sup>th</sup> and the vote in the Senate quickly followed suit. The proposed legislation became law with President Bush's signature on December 20<sup>th</sup>. The Agency is now focused on the completion and approval of the required IRS applications. Once the agreements are finalized, R.I.T.A. will have access to data that will streamline business processes, while significantly enhancing tax revenues through the identification of non-compliant taxpayers.

## **Awards and Acknowledgements**

### ***GFOA Certificate of Achievement***

The Government Finance Officers Association of the United States and Canada (GFOA) awarded a Certificate of Achievement for Excellence in Financial Reporting to the Regional Income Tax Agency for its comprehensive annual financial report for the fiscal year ended December 31, 2005. This was the twenty-first year that the Agency has achieved this prestigious national award recognizing conformance with the highest standards for preparation of state and local government financial reports. In order to be awarded a Certificate of Achievement, a government unit must publish an easily readable and efficiently organized comprehensive annual financial report, whose contents conform to program standards. The CAFR must satisfy both generally accepted accounting principles and applicable legal requirements.

A Certificate of Achievement is valid for a period of only one year. We believe our current report continues to conform to the Certificate of Achievement program requirements and we are submitting it to the GFOA to determine its eligibility for another certificate.

### ***Acknowledgments***

The 2006 Comprehensive Annual Financial Report was prepared with substantial assistance from Lori Starcher and the other staff members of the Finance Department. We wish to thank them for all of their efforts. We also thank the Board of Trustees for their interest and support of this endeavor and for the manner in which they have directed the financial operations of the Regional Income Tax Agency.

Respectfully submitted,

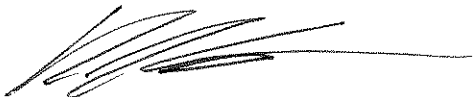

Rick Carbone  
Executive Director



Christy Price  
Deputy Director/Chief Financial Officer

# Regional Income Tax Agency

Officers And Board Members

**December 31, 2006**

---

## COUNCIL OF GOVERNMENTS

### OFFICERS

- President - Mayor Beryl Rothschild – City of University Heights, Ohio
- Secretary - Mayor Kathy Mulcahy – Village of Orange, Ohio
- Treasurer - Mayor Charles DeGross – Village of Moreland Hills, Ohio

## BOARD OF TRUSTEES

### OFFICERS

- Chairman - Timothy Pope, Finance Director/Tax Administrator – City of Middleburg Heights, Ohio
- Vice Chairman - Prashant Shah, Finance Director/Tax Administrator – City of Pepper Pike, Ohio, Treasurer – Village of Moreland Hills, Ohio
- Secretary - Karen Fegan, Finance Director/Tax Administrator – City of North Royalton, Ohio
- Treasurer - Robert Hamilton, Finance Director/Tax Administrator – City of Avon, Ohio

### OTHER BOARD MEMBERS

- Frank J. Brichacek
- Brenda G. Browning - Tax Administrator, City of Reynoldsburg, Ohio
- Anne Fritz - Finance Director/Tax Administrator, City of Westlake, Ohio
- Mayor Gary Gottschalk - Mayor, Village of Oakwood, Ohio
- Jeff Knoblauch - Finance Director/Tax Administrator, City of Hudson, Ohio

# Regional Income Tax Agency

## Management Officials

**December 31, 2006**

---

Executive Director	Mr. Rick Carbone
Deputy Director/Chief Financial Officer	Mrs. Christy Price
Assistant Director of Finance	Mrs. Lori Starcher
Chief Operating Officer	Mr. Richard Barille
Executive Assistant/Board Clerk	Mrs. Lynn Recko
Municipal Services Manager	Mr. Ralph Glatzhofer

### Operations:

Accelerated Collections Director	Mr. Joe Zamiska
Assistant Director of Administrative Services	Ms. Mariann Buemi
Business Compliance Director	Mr. Mark Taranto
Chief Tax Officer	Mr. Gary Chips
Director of Central/Southern Ohio Region	Ms. Lori Gischel
Manager, Youngstown Office	Mr. Michael Sommer

### Information Services:

Chief Information Officer	Mr. Tom Wojnarowski
IS Development Manager	Mr. Mike Kobe
Operations Manager	Mr. Robert Kelley

RITA Org Chart

\*\*\*

December 31, 2006

— Direct Reporting

~ Ad-Hoc Reporting

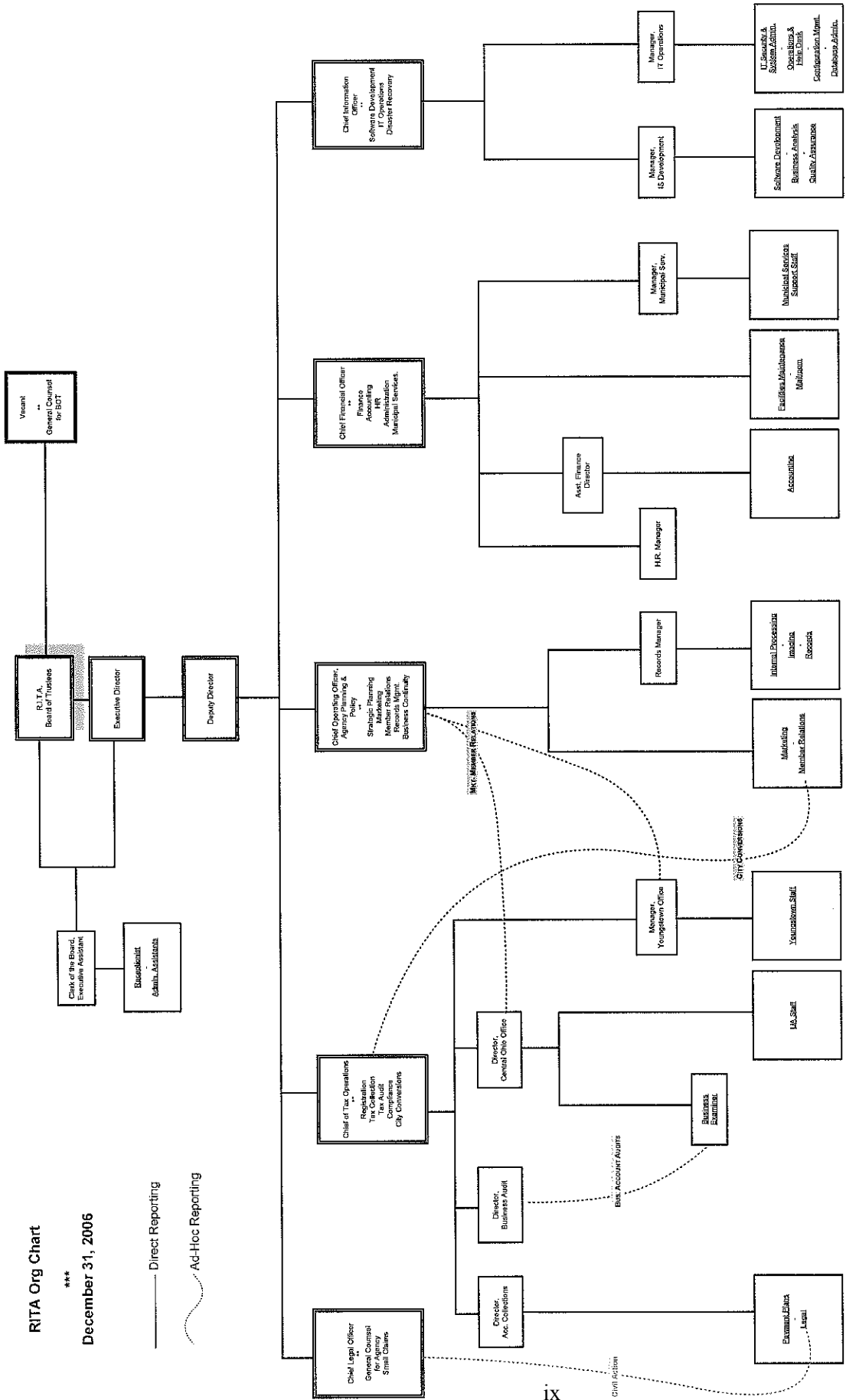

# Certificate of Achievement for Excellence in Financial Reporting

Presented to

Regional Income Tax Agency  
Ohio

For its Comprehensive Annual  
Financial Report  
for the Fiscal Year Ended  
December 31, 2005

A Certificate of Achievement for Excellence in Financial Reporting is presented by the Government Finance Officers Association of the United States and Canada to government units and public employee retirement systems whose comprehensive annual financial reports (CAFRs) achieve the highest standards in government accounting and financial reporting.



President

Executive Director

## **Financial Section**



## Independent Auditors' Report

Board of Trustees  
Regional Income Tax Agency  
Brecksville, Ohio

We have audited the accompanying financial statements of the business-type activities and the aggregate remaining fund information of the Regional Income Tax Agency ("R.I.T.A.") as of and for the years ended December 31, 2006 and 2005, which collectively comprise the R.I.T.A.'s basic financial statements as listed in the table of contents. These financial statements are the responsibility of the Regional Income Tax Agency's management. Our responsibility is to express opinions on these financial statements based on our audits.

We conducted our audits in accordance with auditing standards generally accepted in the United States of America and the standards applicable to financial audits contained in *Government Auditing Standards*, issued by the Comptroller General of the United States. Those standards require that we plan and perform the audit to obtain reasonable assurance about whether the financial statements are free of material misstatement. An audit includes examining, on a test basis, evidence supporting the amounts and disclosures in the financial statements. An audit also includes assessing the accounting principles used and the significant estimates made by management, as well as evaluating the overall financial statement presentation. We believe that our audits provide a reasonable basis for our opinions.

In our opinion, the financial statements referred to above present fairly, in all material respects, the respective financial position of the business-type activities and the aggregate remaining fund information of the Regional Income Tax Agency, as of December 31, 2006 and 2005, and the respective changes in financial position, and, where applicable, cash flows thereof for the years then ended in conformity with accounting principles generally accepted in the United States of America.

As described in Note 14, during the year ended December 31, 2006, the Regional Income Tax Agency implemented GASB Statement No. 44, "*Economic Condition Reporting*", GASB Statement No. 46 "*Net Assets Restricted by Enabling Legislation*" and GASB Statement No. 47, "*Accounting for Termination Benefits*".

In accordance with *Government Auditing Standards*, we have also issued our report dated June 15, 2007 on our consideration of the Regional Income Tax Agency's internal control over financial reporting and on our tests of its compliance with certain provisions of laws, regulations, contracts, and grant agreements and other matters. The purpose of that report is to describe the scope of our testing of internal control over financial reporting and compliance and the results of that testing, and not to provide an opinion on the internal control over financial reporting or on compliance. That report is an integral part of an audit performed in accordance with *Government Auditing Standards* and should be considered in assessing the results of our audit.

Board of Trustees  
Regional Income Tax Agency

The management's discussion and analysis on pages 3 through 12, is not a required part of the basic financial statements, but is supplementary information required by accounting principles generally accepted in the United States of America. We have applied certain limited procedures, which consisted principally of inquiries of management regarding the methods of measurement and presentation of the required supplementary information. However, we did not audit the information and express no opinion on it.

Our audit was conducted for the purpose of forming opinions on the financial statements that collectively comprise the Regional Income Tax Agency's basic financial statements. The introductory section, budgetary comparison information, schedule of changes in fiduciary net assets, and statistical section are presented for purposes of additional analysis and are not a required part of the basic financial statements. The schedule of changes in fiduciary net assets have been subjected to the auditing procedures applied in the audit of the basic financials and, in our opinion, is fairly stated in all material respects in relation to the basic financial statements taken as a whole. For the budgetary comparison information, we have applied certain limited procedures, which consisted principally of inquires of management regarding the methods of measurement and presentation of the supplementary information. However, we did not audit the information and express no opinion on it. The introductory and statistical sections have not been subjected to the auditing procedures applied in the audit of the basic financial statement and, accordingly, we express no opinion on them.

*Cini & Panichi, Inc.*

Cleveland, Ohio  
June 15, 2007

# REGIONAL INCOME TAX AGENCY

## Management's Discussion and Analysis (Unaudited)

The purpose of the discussion and analysis is to provide a general review of the Regional Income Tax Agency's financial activities for the year ended December 31, 2006. The reader should consider this analysis in conjunction with the Transmittal Letter, the basic financial statements and the Statistical Section to gain a further understanding of the Agency's operations and financial performance.

### Financial Highlights

- Receipts grew from \$493 million in 2004, to \$541 million in 2005 and to a record setting \$622 million in 2006.
- The average net cost of collections decreased again for a third year. The average percent of net cost to collections was 2.49% in 2004, 2.16% in 2005 and 1.84% in 2006. In conjunction with this cost reduction, the total amount of net retainer to be refunded to the municipalities increased by about \$2.2 million from the \$4.1 million refunded for 2005.
- As of December 31, 2006 assets exceeded liabilities by \$51,081 versus a balance of \$151,074 as of December 31, 2005.
- The change in net assets is due to a loss from the Municipal Services activities. The related services are offered to our members on a cost basis. Charges are reviewed on an annual basis to ensure that adequate working capital is maintained and charges are adjusted accordingly.
- The repayment of debt during 2006 resulted in the reduction of the Capital Lease Obligations. In 2004 there was a timing difference between the redemption of short-term notes and the issuance of the replacement bonds that carried over into 2005. As a result, the 2005 activity reflected the retirement of the notes and the corresponding reduction in the Capital Lease Obligations.
- The Depreciable Capital Assets, Net increased to reflect the assets that were placed into service during 2006. The assets included the Data Entry System, development software and related computer equipment.

### Overview of the Financial Statements

A fund is a grouping of related accounts utilized to maintain control over the resources used to perform specific activities. R.I.T.A. has two funds; one is proprietary (business-type activity) and the other fund is a fiduciary fund.

The proprietary fund is an enterprise fund that primarily accounts for the Agency's tax collection services. R.I.T.A. provides these services to its members on a cost reimbursement basis with no margin for profit. During the year the operations are funded with advance fees from the municipalities. At year-end, costs are allocated to members based on transactions and amounts collected then the municipalities' individual fee refunds or fee payables are computed. After settlement of the amounts owed/due, the net asset balance for the tax collections activity is brought to zero. The proprietary fund is also used to record the financial software leasing and support activities.

The fiduciary fund accounts for the members' tax receipts held by R.I.T.A. prior to distribution to the municipalities. The funds are invested in short-term instruments and all interest income is used to offset the costs of the tax collection services.

# **REGIONAL INCOME TAX AGENCY**

## **Management's Discussion and Analysis (Unaudited)**

The Regional Income Tax Agency's basic financial statements have three components: 1) Proprietary Fund statements, 2) Fiduciary Fund statements, and 3) Notes to the financial statements. The proprietary fund statements consist of the Statement of Net Assets, the Statement of Revenues, Expenses and Changes in Net Assets and the Statement of Cash Flows. The fiduciary fund statement is the Statement of Fiduciary Net Assets. The CAFR also includes other supplementary information in the Statistical Section.

### **Financial Analysis of the Agency's Financial Position and Results of Operations**

The following tables below present summaries of the Agency's financial position and operations for 2006 compared to the 2005 and 2004 results. The Regional Income Tax Agency implemented Governmental Accounting Standards Board Statement 34, *Basic Financial Statements and Management's Discussion and Analysis for State and Local Governments* in 2004.

The first table is a summary of the Agency's net assets, which condenses information on all of R.I.T.A.'s assets and liabilities, with the difference between the two reported as net assets. Over time, increases or decreases in net assets may serve as a useful indicator of whether the financial position of the Agency is improving or deteriorating. However, take note that the primary purpose of the Agency is to provide tax collection services; as previously noted, R.I.T.A. substantially operates on a cost basis only, with no margin for profit and no net assets. Consequently, any changes in the net asset amount are solely fluctuations in the retained earnings from the Municipal Services software support activities. This department provides low cost, financial system support to member municipalities.

The second table is the Statement of Revenues, Expenses and Changes in Net Assets, which presents a summary of the change in the Agency's net assets. Appropriately, revenue is reported when earned and expense is reported when incurred.

# REGIONAL INCOME TAX AGENCY

## Management's Discussion and Analysis (Unaudited)

Table 1  
Net Assets  
Proprietary Fund

	2006	2005	2004
Assets:			
Current Assets	\$ 15,111,391	\$ 11,600,221	\$ 26,975,138
Capital Assets, Net	16,161,178	17,186,256	20,691,342
Other Noncurrent Assets	<u>7,303,543</u>	<u>7,976,862</u>	<u>5,441,587</u>
Total Assets	<u>38,576,112</u>	<u>36,763,339</u>	<u>53,108,067</u>
Liabilities:			
Current Liabilities	16,119,961	12,660,512	28,130,040
Long-term Liabilities	<u>22,405,070</u>	<u>23,951,753</u>	<u>24,755,584</u>
Total Liabilities	<u>38,525,031</u>	<u>36,612,265</u>	<u>52,885,624</u>
Net Assets:			
Invested in Capital Assets, Net of Related Debt	(487,032)	448,367	733,515
Unrestricted (Deficit)	<u>538,113</u>	<u>(297,293)</u>	<u>(511,072)</u>
Total Net Assets	<u>\$ 51,081</u>	<u>\$ 151,074</u>	<u>\$ 222,443</u>

Overall, there are two significant offsetting factors that resulted in the fluctuation in Current Assets.

- Substantial growth in tax collections provided over \$2 million in additional retainers which contributed to the increase in Cash and Cash Equivalents. The other considerable impact came from the greater interest income. The 2006 rising market rates resulted in approximately \$1 million in additional assets.

The change in liabilities is primarily due to the greater amounts owed to members for retainer refunds in June 2007. Note that during the year retainers are allocated from tax collections to the proprietary fund for use in operations. After the year-end, each member's expenses are computed and any excess retainers are refunded.

The Municipal Services department continued the transition to a new software package. The cost of the ongoing conversions has resulted in the Total Net Assets decrease.

The Statement of Revenue, Expense and Changes in Net Assets reports the proprietary fund operating income and costs, non-operating income and costs, and the change in net assets. This statement, shown in Table 2, reflects the results for 2006, 2005 and 2004.

# REGIONAL INCOME TAX AGENCY

## Management's Discussion and Analysis (Unaudited)

Table 2  
Statement of Revenue, Expenses and Changes in Net Assets

	2006	2005	2004
Operating Revenues:			
Tax Collection Fees	\$ 11,462,953	\$ 11,645,263	\$ 12,249,244
Charges for Services and Other Revenues	<u>1,119,612</u>	<u>999,360</u>	<u>805,442</u>
Total Operating Revenues	<u>12,582,565</u>	<u>12,644,623</u>	<u>13,054,686</u>
Operating Expenses:			
Personal Services	8,627,597	8,208,534	8,729,464
Travel and Transportation	115,773	85,355	118,154
Office Rent and Maintenance	98,901	94,366	94,040
Equipment and Software Maintenance	640,165	616,605	653,344
Cost of Equipment Purchased For Members	150,146	86,498	368
Professional and Processing	1,799,750	1,488,940	1,441,458
Telephone and Utilities	165,493	190,713	215,945
Forms and Envelopes	312,327	306,546	173,307
Insurance	50,944	48,391	49,094
Miscellaneous Expenses	18,211	18,576	20,265
Material and Supplies	706,357	636,192	683,129
Depreciation and Amortization	<u>1,267,507</u>	<u>1,098,343</u>	<u>913,650</u>
Total Operating Expenses	<u>13,953,171</u>	<u>12,879,059</u>	<u>13,092,218</u>
Operating Loss	<u>(1,370,606)</u>	<u>(234,436)</u>	<u>(37,532)</u>
Non - Operating Revenues (Expenses):			
Interest Income	2,226,645	1,247,878	418,272
Interest Expense	(929,298)	(1,084,795)	(405,076)
Loss on Disposal of Capital Assets	<u>(26,734)</u>	<u>(16)</u>	<u>(712)</u>
Total Non - Operating Revenues	<u>1,270,613</u>	<u>163,067</u>	<u>12,484</u>
Change in Net Assets	(99,993)	(71,369)	(25,048)
Net Assets, Beginning of Year	<u>151,074</u>	<u>222,443</u>	<u>247,491</u>
Net Assets, End of Year	\$ <u><u>51,081</u></u>	\$ <u><u>151,074</u></u>	\$ <u><u>222,443</u></u>
Total Revenues			
Operating Revenues	\$ 12,582,565	\$ 12,644,623	\$ 13,054,686
Non-Operating Revenues	<u>2,226,645</u>	<u>1,247,878</u>	<u>418,272</u>
Total Revenues	\$ <u><u>14,809,210</u></u>	\$ <u><u>13,892,501</u></u>	\$ <u><u>13,472,958</u></u>
Total Expenses			
Operating Expenses	\$ 13,953,171	\$ 12,879,059	\$ 13,092,218
Non-Operating Expenses	<u>956,032</u>	<u>1,084,811</u>	<u>405,788</u>
Total Expenses	\$ <u><u>14,909,203</u></u>	\$ <u><u>13,963,870</u></u>	\$ <u><u>13,498,006</u></u>

# REGIONAL INCOME TAX AGENCY

## Management's Discussion and Analysis (Unaudited)

- The tax collection operating fees consist of amounts retained from the municipalities' tax distributions. As the tax services are provided on a cost reimbursement basis, all retainers in excess of actual costs, less other revenues, are refunded back to the municipalities. The tax collection fees, net of refunds, are then reported as the revenues used for operations.
- The charges for services and other revenues include income from the following services:
  - Subpoena programs – R.I.T.A. field auditors travel to local city halls to assist individuals who are delinquent in filing tax returns and to obtain the related tax payments.
  - Small claim lawsuits – R.I.T.A. paralegals represent the municipalities in court to obtain judgments against taxpayers for unpaid taxes.
  - Leasing of accounting software – the Municipal Services department provides software and support services.
  - Miscellaneous fees/reimbursements – includes amounts charged for copies of records, charges for extraordinary services and reimbursements for employee time spent on special projects.
- The change in interest income is primarily due to the significant growth in market interest rates as dictated by the Federal Reserve Bank.
- The Agency's substantial expenses are:
  - Personal Services – As R.I.T.A. is primarily a service-type organization, the bulk of the operating expenses are for personnel. The primary reason for the fluctuations in this expense is the staffing size which was 139 full time equivalents in 2004, 131 in 2005 and 133 in 2006. The variances in staff sizes also contributed to related changes in total health insurance costs.
  - Equipment Software and Maintenance – R.I.T.A. operates a mainframe computer, network servers, robot tape library, scanning and imaging system and interactive voice response unit along with standard office equipment. This expense is for the ongoing software licenses and hardware/equipment maintenance costs. The 2006 amount is comparable to 2005 and 2004. Substantially all of the Cost of Equipment Purchased For Members is for the Municipal Service Department's acquisition of software licenses. This department provides low cost, financial software system support to member municipalities and in the course of business purchases the financial application software. The costs have increased because participating member municipalities are implementing a new software system.

## **REGIONAL INCOME TAX AGENCY**

### **Management's Discussion and Analysis (Unaudited)**

- Professional and Processing – This line item consists of the costs of temporary help to meet peak processing needs, the expense for the two audits (financial and SAS70) that R.I.T.A. undergoes annually, the expense of lockbox services that are utilized to gain processing efficiencies and to maintain high security standards, the costs of Lobbyists to provide assistance in legislative matters at the State House and in Washington D.C. and the cost of short-term technical assistance. The increase in 2006 is due to the technical assistance required for the on-going development of the advanced tax system and greater lockbox costs resulting from the growth in membership.
  - Forms and Envelopes – In 2004 there was a printing error in tax forms for which the printer provided a substantial credit toward the cost of the forms. The expense reported for 2005 and 2006 are more indicative of the actual cost of these items.
  - Material and Supplies – The costs of operating materials and postage are reflected in this line item. The greater postage costs resulting from the growth in membership contributed to the increase in expense.
  - Depreciation and Amortization – The Agency uses the accrual basis of accounting. As such, when assets are purchased the costs are recognized over the life of the resources. The useful lives are 3 to 20 years. The increased expense substantially reflects the added depreciation for the Data Entry System placed into service in 2006.
- Interest expense increased from 2004 to 2005 due to a lack of capitalized interest on projects in process. Interest expense decreased from 2005 to 2006 due to declining principal balances.



# REGIONAL INCOME TAX AGENCY

## Management's Discussion and Analysis (Unaudited)

Graphic interpretations of the Agency operating expenses for 2006 and 2005 are presented as follows:

Graph 1

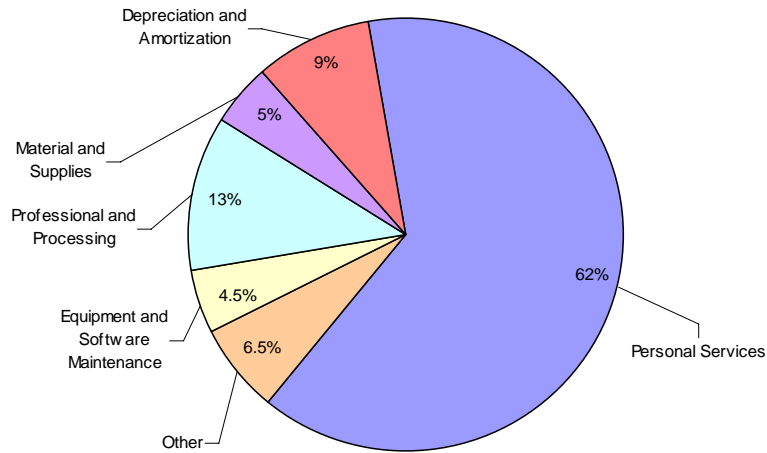

2006 Total Agency Operating Expense

Graph 2

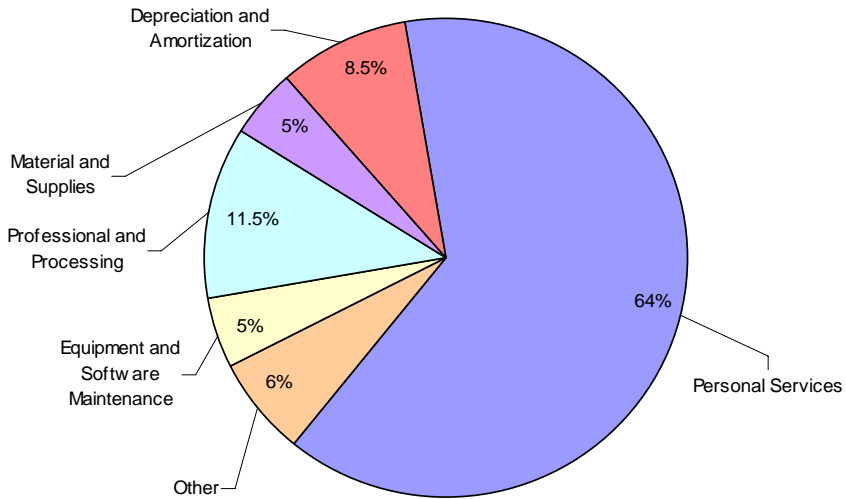

2005 Total Agency Operating Expense

# REGIONAL INCOME TAX AGENCY

## Management's Discussion and Analysis (Unaudited)

### Capital Assets

The following Table indicates the capital asset activity for the years ended December 31, 2006 and 2005.

Table 3  
Capital Asset Activity

	<u>Balance</u> <u>12/31/2005</u>	<u>Additions</u>	<u>Retirements</u>	<u>Transfers</u>	<u>Balance</u> <u>12/31/2006</u>
Nondepreciable Capital Assets:					
Land	\$ 103,660	\$ -	\$ -	\$ -	\$ 103,660
Projects in Process	<u>8,252,838</u>	<u>-</u>	<u>(7,531)</u>	<u>(2,384,430)</u>	<u>5,860,877</u>
Total Nondepreciable Capital Assets	<u>8,356,498</u>	<u>-</u>	<u>(7,531)</u>	<u>(2,384,430)</u>	<u>5,964,537</u>
Capital Assets being depreciated:					
Buildings and Improvements	3,405,681	-	-	-	3,405,681
Office Equipment	10,384,152	275,151	(122,514)	2,384,430	12,921,219
Vehicles	<u>40,021</u>	<u>-</u>	<u>-</u>	<u>-</u>	<u>40,021</u>
Total capital assets being depreciated	13,829,854	275,151	(122,514)	2,384,430	16,366,921
Less: accumulated depreciation and amortization	<u>(5,000,096)</u>	<u>(1,267,353)</u>	<u>97,169</u>	<u>-</u>	<u>(6,170,280)</u>
Net capital assets being depreciated	<u>8,829,758</u>	<u>(992,202)</u>	<u>(25,345)</u>	<u>2,384,430</u>	<u>10,196,641</u>
Total business-type activities capital assets, net	<u>\$ 17,186,256</u>	<u>\$ (992,202)</u>	<u>\$ (32,876)</u>	<u>\$ -</u>	<u>\$ 16,161,178</u>
	<u>Balance</u> <u>12/31/2004</u>	<u>Additions</u>	<u>Retirements</u>	<u>Transfers</u>	<u>Balance</u> <u>12/31/2005</u>
Nondepreciable Capital Assets:					
Land	\$ 103,660	\$ -	\$ -	\$ -	\$ 103,660
Projects in Process	<u>14,775,679</u>	<u>-</u>	<u>(2,500,000)</u>	<u>(4,022,841)</u>	<u>8,252,838</u>
Total Nondepreciable Capital Assets	<u>14,879,339</u>	<u>-</u>	<u>(2,500,000)</u>	<u>(4,022,841)</u>	<u>8,356,498</u>
Capital Assets being depreciated:					
Buildings and Improvements	3,405,681	-	-	-	3,405,681
Office Equipment	6,293,769	92,500	(793)	3,998,676	10,384,152
Equipment Leases to Members	8,651	-	(8,195)	(456)	-
Vehicles	<u>40,021</u>	<u>-</u>	<u>-</u>	<u>-</u>	<u>40,021</u>
Total capital assets being depreciated	9,748,122	92,500	(8,988)	3,998,220	13,829,854
Less: accumulated depreciation and amortization	<u>(3,936,119)</u>	<u>(1,098,344)</u>	<u>9,746</u>	<u>24,621</u>	<u>(5,000,096)</u>
Net capital assets being depreciated	<u>5,812,003</u>	<u>(1,005,844)</u>	<u>758</u>	<u>4,022,841</u>	<u>8,829,758</u>
Total business-type activities capital assets, net	<u>\$ 20,691,342</u>	<u>\$ (1,005,844)</u>	<u>\$ (2,499,242)</u>	<u>\$ -</u>	<u>\$ 17,186,256</u>

## REGIONAL INCOME TAX AGENCY

### Management's Discussion and Analysis (Unaudited)

The 2006 transfer from Projects in Process to Capital Assets being depreciated is substantially due to the new tax Data Entry System placed into service during the year. The fluctuation from 2004 to 2005 is the result of a financial settlement with the Agency's former information technology consultants and depreciation/amortization of tax system software placed into service in 2005.

#### Capital Lease Activity

Details of the changes in the capital lease activity for the year ended December 31, 2006 is as follows:

Table 4

	<u>Balance</u> <u>12/31/2005</u>	<u>Additions</u>	<u>Retirements</u>	<u>Balance</u> <u>12/31/2006</u>	<u>Amounts</u> <u>Due Within</u> <u>One Year</u>
Cleveland-Cuyahoga County Port Authority Capital Lease	\$ 3,228,334	\$ -	\$ (456,667)	\$ 2,771,667	\$ 527,500
Cleveland-Cuyahoga County Port Authority Capital Lease	20,868,001	-	(254,503)	20,613,498	969,742
Unamortized Premium	<u>618,416</u>	<u>-</u>	<u>(51,828)</u>	<u>566,588</u>	<u>49,441</u>
 Total Capital Lease Obligations	 \$ <u>24,714,751</u>	 \$ <u>-</u>	 \$ <u>(762,998)</u>	 \$ <u>23,951,753</u>	 \$ <u>1,546,683</u>

Details of the changes in the capital lease activity for the year ended December 31, 2005 is as follows:

	<u>Balance</u> <u>12/31/2004</u>	<u>Additions</u>	<u>Retirements</u>	<u>Balance</u> <u>12/31/2005</u>	<u>Amounts</u> <u>Due Within</u> <u>One Year</u>
Cleveland-Cuyahoga County Port Authority Capital Lease	\$ 3,736,667	\$ -	\$ (508,333)	\$ 3,228,334	\$ 456,667
National City Leasing Corp. Capital Lease	18,580,000	-	(18,580,000)	-	-
Cleveland-Cuyahoga County Port Authority Capital Lease	20,990,000	-	(121,999)	20,868,001	254,503
Unamortized Premium	<u>672,747</u>	<u>-</u>	<u>(54,331)</u>	<u>618,416</u>	<u>51,828</u>
 Total Capital Lease Obligations	 \$ <u>43,979,414</u>	 \$ <u>-</u>	 \$ <u>(19,264,663)</u>	 \$ <u>24,714,751</u>	 \$ <u>762,998</u>

The activity in 2006 reflects the repayment of the debt as scheduled. Further details on the capital balances and transactions can be found in Notes Five, Six and Seven.

# **REGIONAL INCOME TAX AGENCY**

## **Management's Discussion and Analysis (Unaudited)**

The other significant proprietary financial report is the Statement of Cash Flows, which provides information about the Agency's cash receipts and disbursements during the year. It summarizes net changes in cash resulting from operating, investing and financing activities. The notes to the financial statements provide further information that is essential to a full understanding of the financial statements

### **Contacting the Agency's Financial Management**

This financial report is designed to provide a general overview of the Agency's finances for all interested parties. Questions and requests for additional information regarding this report should be addressed to the Chief Financial Officer, Regional Income Tax Agency, 10107 Brecksville Road, Brecksville, Ohio 44141-3275 or by telephone at 440.526.0900.

# Regional Income Tax Agency

## Statements of Net Assets

**December 31, 2006 and 2005**

	<u>2006</u>	<u>2005</u>
Assets:		
Current Assets:		
Cash and Cash Equivalents	\$ 8,563,044	\$ 5,666,959
Other Assets	167,137	177,651
Receivables:		
Accounts	140,635	129,406
Due from Others	6,239,293	5,623,755
Interest	<u>1,282</u>	<u>2,450</u>
Total Current Assets	<u>15,111,391</u>	<u>11,600,221</u>
Noncurrent Assets:		
Nondepreciable Capital Assets	5,964,537	8,356,498
Depreciable Capital Assets, Net	10,196,641	8,829,758
Due From Trust	6,392,927	6,989,984
Deferred Loan Fees, Net	<u>910,616</u>	<u>986,878</u>
Total Noncurrent Assets	<u>23,464,721</u>	<u>25,163,118</u>
 Total Assets	 <u>38,576,112</u>	 <u>36,763,339</u>
Liabilities:		
Current Liabilities:		
Accounts Payable	431,957	511,343
Accrued Wages and Benefits	1,438,731	1,378,093
Current Portion of Capital Lease	1,546,683	762,998
Other Liabilities	89,311	84,465
Due to Other Governments	7,715,586	5,492,483
Unearned Revenue	<u>4,897,693</u>	<u>4,431,130</u>
Total Current Liabilities	16,119,961	12,660,512
Noncurrent Liabilities:		
Capital Lease Obligation	<u>22,405,070</u>	<u>23,951,753</u>
Total Liabilities	<u>38,525,031</u>	<u>36,612,265</u>
Net Assets:		
Invested in Capital Assets, Net of Related Debt	79,556	1,066,783
Restricted for:		
Debt Service	2,697,059	2,663,419
Capital Improvements	3,695,868	4,326,565
Unrestricted (Deficit)	<u>(6,421,402)</u>	<u>(7,905,693)</u>
Total Net Assets	\$ <u><u>51,081</u></u>	\$ <u><u>151,074</u></u>

See Accompanying Notes to the Basic Financial Statements

## Regional Income Tax Agency

Statements of Revenue, Expenses and Changes in Net Assets

**For The Years Ended December 31, 2006 and 2005**

---

	<u>2006</u>	<u>2005</u>
Operating Revenues:		
Tax Collection Fees	\$ 11,462,953	\$ 11,645,263
Charges for Services and Other Revenues	<u>1,119,612</u>	<u>999,360</u>
Total Operating Revenues	<u>12,582,565</u>	<u>12,644,623</u>
Operating Expenses:		
Personal Services	8,627,597	8,208,534
Travel and Transportation	115,773	85,355
Office Rent and Maintenance	98,901	94,366
Equipment and Software Maintenance	640,165	616,605
Cost of Equipment Purchased For Members	150,146	86,498
Professional and Processing	1,799,750	1,488,940
Telephone and Utilities	165,493	190,713
Forms and Envelopes	312,327	306,546
Insurance	50,944	48,391
Miscellaneous Expenses	18,211	18,576
Material and Supplies	706,357	636,192
Depreciation and Amortization	<u>1,267,507</u>	<u>1,098,343</u>
Total Operating Expenses	<u>13,953,171</u>	<u>12,879,059</u>
Operating Loss	<u>(1,370,606)</u>	<u>(234,436)</u>
Non - Operating Revenues (Expenses):		
Interest Income	2,226,645	1,247,878
Interest Expense	(929,298)	(1,084,795)
Loss on Disposal of Capital Assets	<u>(26,734)</u>	<u>(16)</u>
Total Non - Operating Revenues	<u>1,270,613</u>	<u>163,067</u>
Change in Net Assets	(99,993)	(71,369)
Net Assets, Beginning of Year	<u>151,074</u>	<u>222,443</u>
Net Assets, End of Year	\$ <u><u>51,081</u></u>	\$ <u><u>151,074</u></u>

See Accompanying Notes to the Basic Financial Statements

## Regional Income Tax Agency

### Statements Of Cash Flows

#### For The Years Ended December 31, 2006 and 2005

---

	<u>2006</u>	<u>2005</u>
Cash Flows from Operating Activities:		
Cash Receipts from Municipalities	\$ 18,941,965	\$ 17,019,668
Cash Payments:		
To Suppliers for Goods and Services	(4,122,093)	(3,382,477)
To Employees for Services	(6,315,318)	(6,154,560)
For Employee Benefits	(2,251,641)	(2,073,837)
For Retainer Refund	<u>(4,295,333)</u>	<u>(1,372,971)</u>
Net Cash Provided by Operating Activities	<u>1,957,580</u>	<u>4,035,823</u>
Cash Flows from Non-Capital Financing Activities:		
Release from Trust for Development Purposes	<u>612,986</u>	<u>-</u>
Net Cash Used by Non-Capital Financing Activities	<u>612,986</u>	<u>-</u>
Cash Flows from Capital and Related Financing Activities:		
Acquisition of Capital Assets	(269,163)	(93,273)
Release from Trust for Capital Purposes	207,268	18,604,353
Principal Payments on Capital Lease Obligations	(711,170)	(19,210,332)
Funding of Other Assets-Due From Trust	(223,197)	(108,596)
Interest Payments of Capital Lease Obligations	<u>(904,864)</u>	<u>(1,090,158)</u>
Net Cash Used by Capital and Related Financing Activities	<u>(1,901,126)</u>	<u>(1,898,006)</u>
Cash Flows from Investing Activities:		
Interest on Cash Equivalents	<u>2,226,645</u>	<u>1,247,878</u>
Net Increase in Cash and Cash Equivalents	2,896,085	3,385,695
Cash and Cash Equivalents, Beginning of Year	<u>5,666,959</u>	<u>2,281,264</u>
Cash and Cash Equivalents, End of Year	<u>\$ 8,563,044</u>	<u>\$ 5,666,959</u>

Continued

See Accompanying Notes to the Basic Financial Statements

## Regional Income Tax Agency

### Statements Of Cash Flows (Continued)

#### For The Years Ended December 31, 2006 and 2005

---

	<u>2006</u>	<u>2005</u>
Reconciliation of Operating Loss to Net Cash from Operating Activities:		
Operating Loss	\$ (1,370,606)	\$ (234,436)
Adjustments to Reconcile Operating Loss to Net Cash Provided by Operating Activities:		
Depreciation and Amortization	1,267,507	1,098,343
Changes in Assets and Liabilities:		
Trade Accounts Receivable	(11,229)	72,443
Interest Receivable	1,168	(1,767)
Due to/from Other Funds	(615,538)	113,037
Other Assets	10,514	(3,101)
Accounts Payable	(79,386)	185,895
Accrued Wages and Benefits	60,638	(19,864)
Other Liabilities	4,846	6,912
Due to Other Governments	2,223,103	2,665,260
Unearned Revenues	<u>466,563</u>	<u>153,101</u>
Net Cash Provided by Operating Activities	\$ <u>1,957,580</u>	\$ <u>4,035,823</u>
Supplemental Schedule of Non-Cash Investing, Capital and Related Financing Activities:		
Amortization on Deferred Loan Fees Classified as Interest Expense	\$ <u>76,262</u>	\$ <u>48,968</u>
Reduction in basis of Project in Progress from Legal Settlement	\$ <u>-</u>	\$ <u>2,500,000</u>
Amortization of Premium on Capital Lease Classified as Interest Expense	\$ <u>51,828</u>	\$ <u>54,331</u>

See Accompanying Notes to the Basic Financial Statements



## Regional Income Tax Agency

### Statements of Fiduciary Net Assets

**December 31, 2006 and 2005**

---

	<u>2006</u>	<u>2005</u>
Assets:		
Cash and Cash Equivalents	\$ 40,323,520	\$ 38,471,432
Receivables:		
Interest	31,397	24,661
Income Taxes of Member Municipalities, Net	<u>163,567,543</u>	<u>148,207,385</u>
Total Assets	<u>\$ 203,922,460</u>	<u>\$ 186,703,478</u>
Liabilities:		
Refunds Payable	\$ 1,273,642	\$ 573,399
Due to Others	6,239,293	5,623,756
Due to Other Governments	<u>196,409,525</u>	<u>180,506,323</u>
Total Liabilities	<u>\$ 203,922,460</u>	<u>\$ 186,703,478</u>

See Accompanying Notes to the Basic Financial Statements

# Regional Income Tax Agency

Notes to Financial Statements

**December 31, 2006 and 2005**

---

## **Note 1: Reporting Entity**

The Regional Income Tax Agency (R.I.T.A. or the Agency) is an independent entity that provides an efficient collection of municipal income taxes for the member municipalities of a Regional Council of Governments (the Members) formed under Section 167 of the Ohio Revised Code. The Members elect a nine member Board of Trustees to oversee the Agency operations. R.I.T.A. has a fiduciary responsibility to collect income taxes for its Members at the rates levied and then distribute the income taxes (less related net expenses and refunds) to its Members. Distributions of tax collections to Members are based upon information provided by taxpayers on tax returns and other supporting data.

For financial reporting purposes, R.I.T.A.'s financial statements include all funds for which R.I.T.A. is financially accountable. Financial accountability, as defined by the GASB, exists if R.I.T.A. appoints a voting majority of an organization's governing board and is either able to impose its will on that organization or there is potential for the organization to provide specific financial benefits to, or impose specific burdens on, R.I.T.A. The Agency may also be financially accountable for governmental organizations with a separately elected governing board, a governing board appointed by another government, or a jointly appointed board that is fiscally dependent on R.I.T.A. Also taken into consideration are any other organizations for which the nature and significance of their relationship with R.I.T.A. are such that exclusion would cause the financial statements to be misleading or incomplete. On this basis, there were no other organizations that require incorporation into the financial statements.

## **Note 2: Summary of Significant Accounting Policies**

The following summarizes the significant accounting policies applied in the preparation of the accompanying combined financial statements.

The accompanying financial statements were prepared in accordance with accounting principles generally accepted in the United States of America (GAAP) as applied to governmental units. The Governmental Accounting Standards Board (GASB) is the accepted standard-setting body for establishing governmental accounting and financial reporting principles. R.I.T.A. also applies Financial Accounting Standards Board (FASB) Statements and Interpretations issued after November 30, 1989, provided they do not conflict with or contradict GASB pronouncements. The more significant of the Agency's accounting policies are described below.

# Regional Income Tax Agency

Notes to Financial Statements

**December 31, 2006 and 2005**

---

## **Note 2: Summary of Significant Accounting Policies (continued)**

### **A. Basis of Presentation**

R.I.T.A.'s basic financial statements consist of statements of net assets, statements of revenue, expenses and changes in net assets, statements of cash flows, and statements of fiduciary net assets.

R.I.T.A uses a single enterprise fund and an agency fund to maintain its financial records during the year. A fund is defined as a fiscal and accounting entity with a self-balancing set of accounts.

Enterprise fund reporting focuses on the determination of the change in net assets, financial position and cash flows. An enterprise fund may be used to account for any activity for which a fee is charged to external users.

Fiduciary fund reporting focuses on net assets and changes in net assets. The fiduciary fund category is split into four classifications: Pension trust funds, investment trust funds, private-purpose trust funds and agency funds. Trust funds are used to account for assets held by the entity under a trust agreement for individuals, private organizations, or other governments and are, therefore, not available to support the entity's own programs; the Agency has no trust funds. R.I.T.A.'s agency funds are custodial in nature (assets equal liabilities) and do not involve measurement of results of operations. R.I.T.A.'s only agency fund is used to account for tax collections held by the Agency as an agent for other governments.

### **B. Measurement Focus**

The enterprise fund is accounted for on a flow of economic resources measurement focus. With this measurement focus, all assets and liabilities associated with the operation of these funds are included on the statements of net assets. The statements of revenue, expenses and changes in net assets present increases (i.e. revenues) and decreases (i.e. expenses) in net total assets. The statements of cash flows provide information about how the Agency finances and meets the cash flows need of its enterprise activities.

### **C. Basis of Accounting**

Basis of accounting determines when transactions are recorded in the financial records and reported on the financial statements. The Agency's enterprise fund financial statements as well as the fiduciary fund financial statement are prepared using the accrual basis of accounting.

Revenue is recorded on the accrual basis when the exchange takes place. Expenses are recognized at the time they are incurred. However, with the implementation of GASB Statement No. 33, it was necessary to calculate unearned revenue when recording an estimated receivable that R.I.T.A. will withhold from its members when collecting the taxes on current year earnings. Unearned revenue in the amount of \$4,897,693 at December 31, 2006 and \$4,431,130 at December 31, 2005 has not been recorded as revenue for the following reasons (1) the transactions have not yet been processed, therefore, the money has not yet been earned; and (2) if it were to be recorded as revenue, it would be included in the retainer refund calculation and money that has not yet been collected by R.I.T.A. would be prematurely refunded to its members.

# Regional Income Tax Agency

Notes to Financial Statements

**December 31, 2006 and 2005**

---

## **Note 2: Summary of Significant Accounting Policies (continued)**

### **D. Cash and Cash Equivalents**

During fiscal year 2006 and 2005, the Agency invested in the State Treasury Asset Reserve of Ohio (STAROhio), certificates of deposit, obligations of other United States governmental agencies, and repurchase agreements.

Except for nonparticipating investment contracts, investments are reported at fair value which is based on quoted market prices. Nonparticipating investment contracts and nonnegotiable certificates of deposit are reported at cost.

The Agency has invested funds in STAROhio. STAROhio is an investment pool managed by the State Treasurer's Office which allows governments within the State to pool their funds for investment purposes. STAROhio is not registered with the SEC as an investment company, but does operate in a manner consistent with Rule 2a7 of the Investment Company Act of 1940. Investments in STAROhio are valued at STAROhio's share price which is the price the investment could be sold for on December 31<sup>st</sup>.

Following Ohio statutes, the Board has, by resolution, specified the funds to receive an allocation of interest earnings. Individual investments are specifically identified as to which fund or funds the investment relates and which funds are to be credited with the related interest earnings.

For purposes of the combined statement of cash flows and for presentation on the statements of net assets, investments of the cash management pool and investments with original maturities of three months or less at the time they are purchased by the Agency are considered to be cash equivalents. Investments with an initial maturity of more than three months are reported as investments.

### **E. Allowance for Doubtful Accounts**

Income taxes of member municipalities receivable is shown net of a \$1,337,961 allowance for doubtful accounts at December 31, 2006 and \$2,511,340 at December 31, 2005. The allowance reflects management's best estimate of the amounts that will not be collected. This is based on an assessment of aged receivables and historical collection rates.

### **F. Capital Assets and Depreciation**

All capital assets are recorded at historical cost. R.I.T.A maintains a capitalization threshold of \$500. Depreciation is charged to operations over the assets' estimated useful lives using the straight-line method, with one half year's depreciation in the year of acquisition. Estimated useful lives are as follows:

Building	16 years
Equipment and Software	5 – 20 years
Equipment leased to Members	3 years
Vehicles	5 years

# Regional Income Tax Agency

## Notes to Financial Statements

### **December 31, 2006 and 2005**

---

#### **Note 2: Summary of Significant Accounting Policies (continued)**

##### **G. Deferred Loan Fees**

R.I.T.A. has capitalized the cost of obtaining capital lease financing. Amortization is taken using the effective interest method over the term of the related capital lease obligation. Deferred loan fees of \$910,616 are shown net of \$287,882 of accumulated amortization at December 31, 2006. Deferred loan fees of \$986,878 are shown net of \$211,620 of accumulated depreciation at December 31, 2005.

##### **H. Allocation Of Expenses To Members**

R.I.T.A. allocates to Members net operating expenses in the enterprise fund, after reduction for interest income and charges for services. The Members' allocation is based upon the average of the percentage of each Member's transactions to total transactions and the percentage of each Member's collections to total collections.

##### **I. Compensated Absences**

R.I.T.A.'s employees accumulate earned but unused vacation and sick pay benefits. Vacation and sick pay benefits are accrued when incurred in the enterprise fund and are reported using the termination method dictated by GASB Statement No. 47.

##### **J. Claims**

As described in Note 13, R.I.T.A. was self-insured within certain limits for employee health care benefits. R.I.T.A. recognizes a liability for health care claims if information prior to the issuance of the financial statements indicates that it is probable that a liability has been incurred at the date of the financial statements and the amount of this loss can be reasonably estimated.

##### **K. Unearned Revenue**

Unearned revenue in the enterprise fund represents tax collection fees received that will be earned in subsequent periods as the tax receivables are collected.

##### **L. Net Assets**

Net assets represent the difference between assets and liabilities. Net assets invested in capital assets, net of related debt consists of capital assets (net of accumulation depreciation) plus deferred loan fees, reduced by the outstanding balances of any borrowings (net of premiums and unexpended proceeds) used for the acquisition, construction or improvement of those assets. Net assets are reported as restricted when there are limitations imposed on their use either through the enabling legislation adopted by R.I.T.A. or through external restrictions imposed by creditors, grantors or laws or regulations of other governments. The Agency's restricted net assets are comprised of assets due from trust. R.I.T.A. applies restricted resources when an expense is incurred for which both restricted and unrestricted net assets are available. As of December 31, 2006 and 2005, R.I.T.A. had no net assets restricted by enabling legislation in the statements of net assets.

# Regional Income Tax Agency

Notes to Financial Statements

**December 31, 2006 and 2005**

---

## **Note 2: Summary of Significant Accounting Policies (continued)**

### **M. Revenues and Expenses**

Operating revenues and expenses result from providing tax collection services, extraordinary services and goods to the members. Operating expenses include the cost of these services, including administrative expenses and depreciation on capital assets. Non-operating revenues and expenses are all revenues and expenses not meeting the definition of operating revenues and expenses. Non-operating revenues and expenses include revenues and expenses from capital and related financing activities, and investing activities.

### **N. Use of Estimates**

The preparation of financial statements in conformity with the accounting principles generally accepted in the United States of America requires management to make estimates and assumptions that affect the reported amount of assets and liabilities and disclosure of contingent assets and liabilities at the date of the financial statements and the reported amounts of revenues and expenses during the reporting period. Actual results could differ from those estimates.

### **O. Comparative Data/Reclassifications**

Comparative data for the prior year are presented in order to provide an understanding of the changes in financial position and operations. Certain reclassifications have been made to the 2005 financial statements in order to conform to the 2006 presentation.

## **Note 3: Deposits and Investments**

For 2005, the Agency implemented GASB Statement No. 40, "*Deposit and Investment Risk Disclosures*". GASB Statement No. 40 establishes disclosure requirements for investment credit risk, interest rate risk, deposit custodial risk and foreign currency risk. The implementation of GASB Statement No. 40 did not affect the presentation of the financial statements of the Agency.

Per State of Ohio statutes the Agency classified funds held into three categories. The classifications are described as follows.

Active deposits are amounts necessary to meet current cash needs. Such monies are maintained either in commercial accounts payable or withdrawable on demand accounts, including negotiable order of withdrawal (NOW) accounts, or in money market deposit accounts.

Inactive deposits are monies identified as not needed for use within the current five year period of designation of depositories. Inactive deposits must either be evidenced by certificates of deposit maturing not later than the end of the current period of designation of depositories, or by savings or deposit accounts including, but not limited to, passbook accounts.

# Regional Income Tax Agency

## Notes to Financial Statements

### **December 31, 2006 and 2005**

---

#### **Note 3: Deposits and Investments (continued)**

Interim monies are those funds that are not needed for immediate use but which will be needed before the end of the current period of designation of depositories. Interim monies may be deposited or invested in the following securities:

1. Bonds, notes or other obligations of or guaranteed by the United States, or those for which the faith of the United States is pledged for the payment of principal and interest therein.
2. Bonds, notes, debentures or other obligations or securities issued by any federal government agency.
3. Deposits with financial institutions and savings and loan associations, collateralized, as required by law.
4. State Treasurer's investment pool (STAROhio).
5. Bonds and other obligations of the State of Ohio.
6. Commercial paper rated A1/P1 by Moody's and Standard and Poor's rating agencies.
7. Repurchase agreements fully collateralized with securities listed under 1 and 2 above.

Investments in mortgage backed securities, principal only or interest only or strips, reverse repurchase agreements and derivatives are forbidden. The use of leverage and short selling are also prohibited. Repurchase agreements are limited to maximum maturities of thirty days. A maximum of ten million dollars can be invested over a longer period not to exceed one year with the exception of the debt reserve funds established under the agreements with the Cleveland-Cuyahoga County Port Authority. The debt reserve funds may be invested for the maximum time allowed under the Ohio Revised Code. All other funds shall be invested for a period not to exceed 45 days.

#### **Deposits**

*Custodial credit risk* is the risk that, in the event of bank failure, the Agency's deposits may be lost. Protection of the Agency's deposits is provided by the Federal Deposit Insurance Corporation (FDIC), by eligible securities pledged by the financial institution, by surety company bonds or by a single collateral pool established by the financial institution.

Public depositories must give security for all public funds on deposit. These institutions may either specifically collateralize individual accounts in lieu of amounts insured by the FDIC or may pledge a pool of government securities that have a face value that is at least 110 percent of the total value of public monies on deposit at the institution. Repurchase agreements must be secured by the specific government securities upon which the repurchase agreements are based. These securities must be obligations of or guaranteed by the United States and mature or be redeemable within five years of the date of the related repurchase agreement. The market value of the securities subject to a repurchase agreement must exceed the value of the principal by two percent and be marked to market daily. State law does not require security for public deposits and investments to be maintained in R.I.T.A.'s name.

At December 31, 2006, the carrying amount of R.I.T.A.'s deposits was \$220,633 and the bank balance was \$1,652,302. Of the bank balance, \$403,249 was covered by FDIC insurance and \$1,249,053 was uninsured and collateralized with securities held by the pledging institution's trust department, not in the Agency's name. At year end, R.I.T.A. had \$400 of undeposited cash on hand.

# Regional Income Tax Agency

Notes to Financial Statements

## December 31, 2006 and 2005

---

### Note 3: Deposits and Investments (continued)

At December 31, 2005, the carrying amount of R.I.T.A.'s deposits was \$693,033 and the bank balance was \$1,859,824. Of the bank balance, \$421,645 was covered by FDIC insurance and \$1,438,179 was uninsured and collateralized with securities held by the pledging institution's trust department, not in the Agency's name. At year end, R.I.T.A. had \$400 of undeposited cash on hand.

#### Investments

Investments are reported at fair value. As of December 31, 2006, the Agency had the following investments:

	<u>Fair Value</u>	<u>Weighted Average Maturity (days)</u>
Federal Home Loan Bank Bonds	\$ 9,742,119	35
Repurchase Agreements	38,128,297	1
StarOhio	<u>795,115</u>	1
Portfolio Total	<u>\$ 48,665,531</u>	

As of December 31, 2005, the Agency had the following investments:

	<u>Fair Value</u>	<u>Weighted Average Maturity (days)</u>
Repurchase Agreements	\$ 42,687,487	1
StarOhio	<u>757,471</u>	1
Portfolio Total	<u>\$ 43,444,958</u>	

Safety of principal is an investment objective of the Regional Income Tax Agency. The Agency's policy states that each transaction shall seek to first ensure that capital losses are avoided, whether they are from securities, defaults or erosion of market value. The Agency seeks to attain market rates of return on its investments, consistent with constraints imposed by its safety objectives, cash flow considerations and state laws that restrict the placement of certain public funds.

**Interest Rate Risk** arises because potential purchasers of debt securities will not agree to pay face value for those securities if interest rates subsequently increase. The Agency mitigates risk by timing investment maturities to match operating cash requirements. In addition, due to the bi-monthly cash distribution schedule, investments must be, by necessity, of a relatively short duration.

**Custodial Risk** for investments is the risk that, in the event of the failure of the counterparty to a transaction, the Agency will not be able to recover the value of the investment or collateral securities that are in the possession of an outside party. Investments may only be made through institutions that are members of the National Association of Securities Dealers. The Board of Trustees reviews and approves these institutions.



# Regional Income Tax Agency

Notes to Financial Statements

**December 31, 2006 and 2005**

---

## **Note 3: Deposits and Investments (continued)**

*Credit Risk* is addressed by the Agency's investment policy by the requirements that all investments are authorized by Ohio Revised Code and that the portfolio be diversified by issuer. All investments by the Agency are registered and carry a AAA rating by Standard & Poor's.

*Concentration of Credit Risk* is defined by the Governmental Accounting Standards Board as five percent or more in the securities of a single issuer. The Agency's investment policy requires that the repurchase agreements cannot exceed ten percent (10%) of the capital of the issuing institution or seventy-five percent (75%) of the Agency investment portfolio with the exception that the Agency is authorized to invest one-hundred percent (100%) of its portfolio in repurchase agreements or other investment vehicles with the State Treasurer's investment pool (Star Ohio).

The following is the Agency's allocation as of December 31, 2006:

<u>Investment Issue</u>	<u>Percentage of Investments</u>
The Huntington National Bank	56.71%
Charter One Bank	30.60
Fifth Third Bank	11.06
STAROhio	1.63

The following is the Agency's allocation as of December 31, 2005:

<u>Investment Issue</u>	<u>Percentage of Investments</u>
The Huntington National Bank	66.79%
Charter One Bank	31.47
STAROhio	1.74

## **Note 4: Receivables**

Accounts receivable at December 31, 2006 and 2005 included on the statements of net assets consists primarily of subpoena fees receivable and miscellaneous service receivables due from member municipalities. Management considers all receivables fully collectible.

# Regional Income Tax Agency

## Notes to Financial Statements

### December 31, 2006 and 2005

#### Note 5: Capital Assets

Capital asset activity for the year ended December 31, 2006, was as follows:

	Balance 12/31/2005	Additions	Retirements	Transfers	Balance 12/31/2006
Nondepreciable Capital Assets:					
Land	\$ 103,660	\$ -	\$ -	\$ -	\$ 103,660
Projects in Process	<u>8,252,838</u>	<u>-</u>	<u>(7,531)</u>	<u>(2,384,430)</u>	<u>5,860,877</u>
Total Nondepreciable Capital Assets	<u>8,356,498</u>	<u>-</u>	<u>(7,531)</u>	<u>(2,384,430)</u>	<u>5,964,537</u>
Capital Assets being depreciated:					
Buildings and Improvements	3,405,681	-	-	-	3,405,681
Office Equipment	10,384,152	275,151	(122,514)	2,384,430	12,921,219
Vehicles	<u>40,021</u>	<u>-</u>	<u>-</u>	<u>-</u>	<u>40,021</u>
Total capital assets being depreciated	<u>13,829,854</u>	<u>275,151</u>	<u>(122,514)</u>	<u>2,384,430</u>	<u>16,366,921</u>
Less: accumulated depreciation and amortization for:					
Building and Improvements	(1,347,737)	(254,413)	-	-	(1,602,150)
Office Equipment	(3,612,338)	(1,012,940)	97,169	-	(4,528,109)
Vehicles	<u>(40,021)</u>	<u>-</u>	<u>-</u>	<u>-</u>	<u>(40,021)</u>
	<u>(5,000,096)</u>	<u>(1,267,353)</u>	<u>97,169</u>	<u>-</u>	<u>(6,170,280)</u>
Net capital assets being depreciated	<u>8,829,758</u>	<u>(992,202)</u>	<u>(25,345)</u>	<u>2,384,430</u>	<u>10,196,641</u>
Total business-type activities capital assets, net	\$ <u>17,186,256</u>	\$ <u>(992,202)</u>	\$ <u>(32,876)</u>	\$ <u>-</u>	\$ <u>16,161,178</u>

Capital asset activity for the year ended December 31, 2005, was as follows:

	Balance 12/31/2004	Additions	Retirements	Transfers	Balance 12/31/2005
Nondepreciable Capital Assets:					
Land	\$ 103,660	\$ -	\$ -	\$ -	\$ 103,660
Projects in Process	<u>14,775,679</u>	<u>-</u>	<u>(2,500,000)</u>	<u>(4,022,841)</u>	<u>8,252,838</u>
Total Nondepreciable Capital Assets	<u>14,879,339</u>	<u>-</u>	<u>(2,500,000)</u>	<u>(4,022,841)</u>	<u>8,356,498</u>
Capital Assets being depreciated:					
Buildings and Improvements	3,405,681	-	-	-	3,405,681
Office Equipment	6,293,769	92,500	(793)	3,998,676	10,384,152
Equipment Leases to Members	8,651	-	(8,195)	(456)	-
Vehicles	<u>40,021</u>	<u>-</u>	<u>-</u>	<u>-</u>	<u>40,021</u>
Total capital assets being depreciated	<u>9,748,122</u>	<u>92,500</u>	<u>(8,988)</u>	<u>3,998,220</u>	<u>13,829,854</u>
Less: accumulated depreciation and amortization for:					
Building and Improvements	(1,125,794)	(221,943)	-	-	(1,347,737)
Office Equipment	(2,765,763)	(872,290)	1,551	24,164	(3,612,338)
Equipment Leases to Members	(8,543)	(109)	8,195	457	-
Vehicles	<u>(36,019)</u>	<u>(4,002)</u>	<u>-</u>	<u>-</u>	<u>(40,021)</u>
	<u>(3,936,119)</u>	<u>(1,098,344)</u>	<u>9,746</u>	<u>24,621</u>	<u>(5,000,096)</u>
Net capital assets being depreciated	<u>5,812,003</u>	<u>(1,005,844)</u>	<u>758</u>	<u>4,022,841</u>	<u>8,829,758</u>
Total business-type activities capital assets, net	\$ <u>20,691,342</u>	\$ <u>(1,005,844)</u>	\$ <u>(2,499,242)</u>	\$ <u>-</u>	\$ <u>17,186,256</u>

## Regional Income Tax Agency

### Notes to Financial Statements

#### December 31, 2006 and 2005

##### Note 5: Capital Assets (continued)

The basis of projects in progress during the year ended December 31, 2005 was reduced by \$2,500,000 to record the net proceeds of a legal settlement.

##### Note 6: Capital Lease Activity

Details of the changes in the capital lease activity for the year ended December 31, 2006 was as follows:

	Balance <u>12/31/2005</u>	<u>Additions</u>	<u>Retirements</u>	Balance <u>12/31/2006</u>	Amounts Due Within <u>One Year</u>
Cleveland-Cuyahoga County Port Authority Capital Lease	\$ 3,228,334	\$ -	\$ (456,667)	\$ 2,771,667	\$ 527,500
Cleveland-Cuyahoga County Port Authority Capital Lease	20,868,001	-	(254,503)	20,613,498	969,742
Unamortized Premium	<u>618,416</u>	<u>-</u>	<u>(51,828)</u>	<u>566,588</u>	<u>49,441</u>
Total Capital Lease Obligations	\$ <u>24,714,751</u>	\$ <u>-</u>	\$ <u>(762,998)</u>	\$ <u>23,951,753</u>	\$ <u>1,546,683</u>

Details of the changes in the capital lease activity for the year ended December 31, 2005 was as follows:

	Balance <u>12/31/2004</u>	<u>Additions</u>	<u>Retirements</u>	Balance <u>12/31/2005</u>	Amounts Due Within <u>One Year</u>
Cleveland-Cuyahoga County Port Authority Capital Lease	\$ 3,736,667	\$ -	\$ (508,333)	\$ 3,228,334	\$ 456,667
National City Leasing Corp. Capital Lease	18,580,000	-	(18,580,000)	-	-
Cleveland-Cuyahoga County Port Authority Capital Lease	20,990,000	-	(121,999)	20,868,001	254,503
Unamortized Premium	<u>672,747</u>	<u>-</u>	<u>(54,331)</u>	<u>618,416</u>	<u>51,828</u>
Total Capital Lease Obligations	\$ <u>43,979,414</u>	\$ <u>-</u>	\$ <u>(19,264,663)</u>	\$ <u>24,714,751</u>	\$ <u>762,998</u>

##### Note 7: Capital Lease Commitments

Effective December 19, 2000, the Members entered into a capital lease agreement with the Cleveland-Cuyahoga County Port Authority ("Authority"). The Members are leasing the "Series 2000B Project" from the Authority. The "Series 2000B Project" provides funds for the acquisition and installation of personal property consisting of an HVAC system, computer equipment, computer software and certain other furnishings and equipment to be located and used at the Agency.

The initial term of the lease agreement ended on December 31, 2001, and is renewable for successive one-year terms upon appropriation of funds by R.I.T.A.'s Board of Trustees to pay the rental payments. The final renewal term ends on November 15, 2010 when the remaining balance under the lease is due. At the end of the lease term, the Members have the option to purchase the "Series 2000B Project" for \$1. Interest on the obligation is at 6% per annum. An administrative and trustee fee of 0.3% is also incurred on an annual basis.

# Regional Income Tax Agency

## Notes to Financial Statements

### December 31, 2006 and 2005

---

#### **Note 7: Capital Lease Commitments (continued)**

Future minimum lease payments under the “Series 2000B Project” lease agreement are as follows:

2007	693,899
2008	696,012
2009	700,115
2010	<u>1,133,311</u>
Future minimum lease payments	3,223,337
Less amount representing interest	<u>451,670</u>
Present value of future minimum lease payments	\$ <u>2,771,667</u>

The 2010 repayment of this obligation will be partially offset by debt reserve funds included in the Due From Trust balance.

On December 1, 2001, the Members entered into a lease agreement with National City Leasing Corporation (“NCLC”) to provide funds for the acquisition and installation of personal property consisting of computer equipment, computer software and certain other furnishings and equipment to be located and used at the Agency. The NCLC lease agreement was refinanced on January 31, 2003 and 2004. The refinancing on January 31, 2004, in the amount of \$18,580,000, had a maturity of December 31, 2004, however the Agency exercised its option to extend the maturity date to January 28, 2005. Interest on this obligation was 2.38% per annum. On December 30, 2004, the Agency obtained “Series 2004” permanent bond financing for this obligation with the Authority.

The new capital lease agreement signed by the Agency generated proceeds of \$21,662,747. This exceeded the par amount of \$20,990,000, resulting in a premium of \$672,747. From the proceeds, \$20,724,937 was placed in trust to refinance the NCLC capital lease in January 2005 and to establish new bond reserve and retirement funds, while \$937,810 was capitalized as deferred loan fees. The leased personal property includes the HVAC system, other improvements and furnishings of the project site, and the development, furnishing, and installing of certain computer hardware and software. The initial lease term was December 30, 2004 to December 31, 2005, however, the Agency exercised its option to extend the maturity date to December 31, 2006. The lessee can renew the lease for consecutive one-year periods, except that the final renewal term will mature on November 15, 2022. The Agency intends to renew the lease through the maturity date and this is stated in the lease. The lease includes a \$10 bargain purchase option therefore management has recorded the obligation as a capital lease. The lease has an imputed interest rate of 4.726%.

Future minimum lease payments under the “Series 2004” lease agreement are as follows:

2007	\$ 1,922,979
2008	1,883,537
2009	1,861,037
2010	1,938,204
2011	2,161,333
Thereafter	<u>19,225,544</u>
Future minimum lease payments	28,992,634
Less amount representing interest	<u>8,379,136</u>
Present value of future minimum lease payments	\$ <u>20,613,498</u>

# Regional Income Tax Agency

## Notes to Financial Statements

### **December 31, 2006 and 2005**

---

#### **Note 7: Capital Lease Commitments (continued)**

The new capital lease agreement contains various covenants, including a minimum amount of annual income tax collections. If the minimum amount of annual income tax collections are not met, the lease could be subject to a special mandatory redemption.

Proceeds in the amount of \$6,392,927 and \$6,989,984 from capital lease arrangements are held in trust at December 31, 2006 and 2005, respectively. The funds consist of bond reserve and project funds. Project funds are distributed as project costs are incurred. Project costs in the amount of \$16,515,698 have been capitalized to date as of December 31, 2006. Of this amount, capital assets of \$10,654,821 and \$8,262,860 have been placed into service as of December 31, 2006 and 2005, respectively. Accumulated depreciation of \$2,149,125 at December 31, 2006 and \$2,013,425 at December 31, 2005 has been recorded to the assets placed in service. During the year ended December 31, 2005, interest of \$467,998 was capitalized.

The Agency has utilized capital lease proceeds to implement a new, multi-dimensional tax information system. To date, operational systems include an Imaging and Document Workflow system, a Telephone Interactive Voice Recognition Unit, a Customer Relationship Management system, a Virtual Private Network, a Right Fax system, an eProcess system and a Data Entry system.

Non-Depreciable Capital Assets, excluding land, on the statements of net assets consists of costs incurred prior to December 31, 2006 and 2005 for new systems, which have not yet been put into operation. The amount represents a new core tax system.

The tax system is being introduced by phase. Management believes this plan has proven to be effective in the roll out of functionality and that this approach is the most efficient method of implementation.

In 2004, the Agency early adopted GASB Statement No. 42, *Accounting and Financial Reporting for Impairment of Capital Assets and For Insurance Recoveries*. This standard establishes accounting and financial reporting standards for impairment of capital assets. The Agency has performed an evaluation of construction costs to date to determine if impairment exists. During 2006, project costs of \$54,067 were identified as impairment expense and were written off before year-end. No impairment was identified to exist at December 31, 2005.

# Regional Income Tax Agency

## Notes to Financial Statements

### December 31, 2006 and 2005

---

#### **Note 8: Tax Collection Fees**

During each year, R.I.T.A. withholds, as its tax collection fee, a portion of the taxes, penalties and interest collected. At year end, the amount withheld in excess of operating expenses less other revenues is determined and recorded as amounts Due to Other Governments. In the subsequent year, this excess is distributed to the Members. At December 31, 2006 and 2005, the amount due to other governments is calculated as follows:

	<u>2006</u>	<u>2005</u>
Amounts withheld for tax collection fees	\$ 19,178,540	\$ 17,137,746
Charges for services and other revenues (expense)	662,417	576,380
Net interest income	<u>2,219,436</u>	<u>1,241,201</u>
Subtotal	22,060,393	18,955,327
Operating expenses and interest expense	<u>14,344,807</u>	<u>13,462,844</u>
Excess of amounts withheld (due to other governments)	\$ <u>7,715,586</u>	\$ <u>5,492,483</u>

#### **Note 9: Compensated Absences**

R.I.T.A. employees accumulate vacation leave and unlimited sick leave based upon hours worked and years of service. Upon retirement or death, employees are paid 25 percent of accumulated sick leave, not to exceed 250 hours. Sick leave in excess of the 250 hour maximum is not paid upon retirement or death, but will be paid only upon illness while in the employment of R.I.T.A.

During the first seven years of employment, employees can earn 10 days of vacation leave per year. During the next seven years of employment, employees can earn 15 days per year. After 14 years of employment, an employee can earn 20 days and after 22 years of service, employees can earn 25 days per year. Employees may accrue, and be paid upon termination of employment with R.I.T.A., up to a maximum of 20 days in the first six years of employment, 30 days during the next seven years of employment, 40 days in the subsequent eight years and 50 days thereafter.

As of December 31, 2006, the liability accrued for vacation and sick leave is \$848,351 compared to \$752,619 at December 31, 2005. The liability is included in accrued wages and benefits on the statements of net assets.

#### **Note 10: Operating Lease Commitments**

##### **R.I.T.A. as Lessor**

R.I.T.A. continues to lease computer software to Members and the leases have month-to-month payment terms. The total rental income recognized by the enterprise fund under R.I.T.A.'s hardware and software leases during 2006 and 2005 was \$276,956 and \$330,070, respectively.

##### **R.I.T.A. as Lessee**

The Regional Income Tax Agency leases office space and computer equipment under long-term operating leases. Rent expense related to the leases totaled \$36,833 and \$26,154 in 2006 and 2005 respectively.

# Regional Income Tax Agency

Notes to Financial Statements

**December 31, 2006 and 2005**

---

**Note 10: Operating Lease Commitments (continued)**

Future minimum rental commitments for the organization's non-cancelable operating leases are as follows:

2007	\$ 47,655
2008	43,867
2009	10,679

**Note 11: Defined Benefit Pension Plans – Ohio Public Employees Retirement System**

R.I.T.A. participates in the Ohio Public Employees Retirement System (OPERS). OPERS administers three separate pension plans. The Traditional Pension Plan is a cost-sharing, multiple-employer defined benefit pension plan. The Member-Directed Plan is a defined contribution plan in which the member invests both member and employer contributions (employer contributions vest over five years at 20% per year). Under the member directed plan, members accumulate retirement assets equal to the value of the member and vested employer contributions plus any investment earnings. The Combined Plan is a cost-sharing, multiple-employer defined benefit pension plan. Under the combined plan, OPERS invests employer contributions to provide a formula retirement benefit similar in nature to the Traditional Pension Plan benefit. Member contributions, the investment of which is self-directed by the members, accumulate retirement assets in a manner similar to the Member-Directed Plan.

OPERS provides retirement, disability, survivor and death benefits and annual cost of living adjustments to members of the Traditional Pension and Combined Plans. Members of the member directed plan do not qualify for ancillary benefits. Authority to establish and amend benefits is provided by Chapter 145 of the Ohio Revised Code. OPERS issues a stand-alone financial report that may be obtained by writing to OPERS, 277 E. Town St., Columbus, OH 43215-4642 or by calling (614) 222-6701 or (800) 222-7377.

For the year ended December 31, 2006 the members of all three plans were required to contribute 9.00 percent of their annual covered salary to fund pension obligations. R.I.T.A. contributed 13.70 percent of covered payroll, of which 4.50 percent was used to fund health care coverage for retirees. For the year ended December 31, 2005 the members of all three plans were required to contribute 8.50 percent of their annual covered salary to fund pension obligations. R.I.T.A. contributed 13.55 percent of covered payroll, of which 4.00 percent was used to fund health care coverage for retirees. The contribution rate is determined actuarially. The Ohio Revised Code provides statutory authority for member and employer contributions.

The Agency's required contributions for pension obligations to the traditional and combined plans for the years ended December 31, 2006, 2005, and 2004 were \$802,391, \$824,505, and \$839,079, respectively, equal to the required contributions for each year. The full amount has been contributed for all three years.

# Regional Income Tax Agency

## Notes to Financial Statements

### **December 31, 2006 and 2005**

---

#### **Note 12: Postemployment Benefits – Ohio Public Employees Retirement System**

The Ohio Public Employees Retirement System (OPERS) administers three separate pension plans: the Traditional Pension Plan – a cost-sharing multiple-employer defined benefit pension plan; the Member-Directed Plan – a defined contribution plan; and the Combined Plan – a cost-sharing multiple-employer defined benefit pension plan.

OPERS provides retirement, disability, survivor and post-retirement health care benefits to qualifying members of both the Traditional Pension and the Combined Plans. Members of the Member-Directed Plan do not qualify for ancillary benefits, including post-employment health care coverage.

In order to qualify for post-retirement health care coverage, age and service retirees under the Traditional Pension and Combined Plans must have 10 or more years of qualifying Ohio service credit. Health care coverage for disability recipients and qualified survivor recipients is available. The health care coverage provided by the Retirement System is considered an Other Post-employment Benefit (OPEB) as described in GASB Statement No. 12.

A portion of each employer's contribution to OPERS is set aside for the funding of post-retirement health care. The Ohio Revised Code provides statutory authority requiring employers to fund post-retirement health care through their contributions to OPERS. The 2006 employer contribution rate was 13.70 percent of covered payroll. The portion of employer contributions for all employers allocated to health care was 4.50 percent.

Benefits are advance-funded using the entry age normal actuarial cost method. Significant actuarial assumptions, based on OPERS's latest actuarial review performed as of December 31, 2005, include a rate of return on investments of 6.5 percent. An annual increase of 4.0 percent, compounded annually, is the base portion of the individual pay increase assumption. This assumes no change in the number of active employees. Additionally, annual pay increase, over and above the 4.0 percent base increase, were assumed to range from 0.50 percent to 6.3 percent. Health care costs were assumed to increase at the projected wage inflation rate plus an additional factor ranging from 0.5 percent to 6 percent for the next nine years. In subsequent years (10 and beyond) health care costs were assumed to increase at 4 percent (the projected wage inflation rate).

All investments are carried at market value. For actuarial valuation purposes, a smoothed market approach is used. Under this approach, assets are adjusted to reflect 25% of unrealized market appreciation or depreciation on investment assets annually, not to exceed a 12% corridor.

At December 31, 2006, the number of active contributing participants in the Traditional and Combined Plans totaled 358,804. The Agency's actual contributions for 2006, which were used to fund postemployment benefits, were \$263,585. The actual contribution and the actuarially required contribution amounts are the same. OPERS's net assets available for payment of benefits at December 31, 2005, (the latest information available) were \$ 11.1 billion. The actuarially accrued liability and the unfounded actuarially accrued liability for OPEB, based on the actuarial cost method used, were \$31.3 billion and \$20.2 billion, respectively.

On September 9, 2004, the OPERS Retirement Board adopted a Health Care Preservation Plan (HCPP) with an effective date of January 1, 2007. In addition to the HCPP, OPERS has taken additional action to improve the solvency of the Health Care Fund in 2005 by creating a separate investment pool for health care assets.



# Regional Income Tax Agency

## Notes to Financial Statements

### December 31, 2006 and 2005

---

#### Note 12: Postemployment Benefits – Ohio Public Employees Retirement System (continued)

Member and employer contribution rates increased as of January 1, 2006 and January 1, 2007, which will allow additional funds to be allocated to the health care plan.

Under the HCPP, retirees eligible for health care coverage will receive a graded monthly allocation based on their years of service at retirement. The Plan incorporates a cafeteria approach, offering a broad range of health care options that allow benefit recipients to use their monthly allocation to purchase health care coverage customized to meet their individual needs. If the monthly allocation exceeds the cost of the options selected, the excess is deposited into a Retirement Medical Account that can be used to fund future health care expenses.

#### Note 13: Risk Management

R.I.T.A. is exposed to various risks of loss including employee health care costs, errors and omissions, torts and legal judgments, and damage and destruction of assets.

R.I.T.A. carries \$1,000,000 of comprehensive general liability insurance coverage, a \$2,000,000 umbrella policy, as well as insurance coverage for R.I.T.A. business interruption and property losses. R.I.T.A. is insured through the State of Ohio for workers' compensation. R.I.T.A. employees have two health care options, both of which are standard premium-based insurance coverage. Previously, R.I.T.A. offered health care through a self-insurance policy; however, effective January 1, 2006, the self-insured health care plan was replaced by a second standard premium-based insurance plan. R.I.T.A.'s self-insurance costs related to employee health care covered up to a maximum exposure of \$27,500 per employee, with an aggregate annual exposure of \$1,009,875. As of December 31, 2006 and 2005, the liability accrued for health care claims was \$160,000 and \$322,505, respectively, and is included in accrued wages and benefits on the statements of net assets. The liabilities represent R.I.T.A.'s best estimates based upon available information and include an estimate for claims that have been incurred but not reported.

Changes in R.I.T.A.'s health care claims liability were as follows:

	Balance at Beginning Of Year	Current Year Claims and Changes in Estimates	Claim Payments	Balance at End of Year
2005	\$ 312,337	\$ 764,939	\$(754,771)	\$ 322,505
2006	322,505	(101,934)	(60,571)	160,000

# Regional Income Tax Agency

Notes to Financial Statements

**December 31, 2006 and 2005**

---

## **Note 14: Change in Accounting Principles**

For fiscal year 2006, the Agency implemented GASB Statement No. 44, "*Economic Condition Reporting: The Statistical Section*", GASB Statement No. 46, "*Net Assets Restricted by Enabling Legislation*", and GASB Statement No. 47, "*Accounting for Termination Benefits*".

GASB Statement No. 44 improves the understandability and usefulness of the information that the State and local governments present as supplementary information in the statistical section.

GASB Statement No. 46 clarifies when net assets should be restricted based on enabling legislation.

GASB Statement No. 47 provides guidance to governmental employers for measuring, recognizing, and reporting liabilities and expenses/expenditures related to all termination benefits without limitation as to the period of time during which the benefits are offered.

Implementation of GASB Statements No. 46 and No. 47 did not affect the presentation of the financial statements of the Agency.

## Regional Income Tax Agency

### Schedule of Changes in Fiduciary Net Assets

#### For the Year Ended December 31, 2006

---

	Balance at January 1, 2006	Additions	Deductions	Balance at December 31, 2006
<b>Assets:</b>				
Cash and Cash Equivalents	\$ 38,471,432	\$ 623,185,695	\$ (621,333,607)	\$ 40,323,520
Receivables:				
Interest	24,661	31,397	(24,661)	31,397
Income Taxes of Member Municipalities, Net	<u>148,207,385</u>	<u>163,567,543</u>	<u>(148,207,385)</u>	<u>163,567,543</u>
Total Assets	\$ <u>186,703,478</u>	\$ <u>786,784,635</u>	\$ <u>(769,565,653)</u>	\$ <u>203,922,460</u>
<b>Liabilities:</b>				
Refunds Payable	\$ 573,399	\$ 14,890,070	\$ (14,189,827)	\$ 1,273,642
Due to Other Funds	5,623,756	18,451,073	(17,835,536)	6,239,293
Due to Other Governments	<u>180,506,323</u>	<u>619,398,043</u>	<u>(603,494,841)</u>	<u>196,409,525</u>
Total Liabilities	\$ <u>186,703,478</u>	\$ <u>652,739,186</u>	\$ <u>(635,520,204)</u>	\$ <u>203,922,460</u>

## Regional Income Tax Agency

Schedule of Revenues and Expenses – Budget and Actual (GAAP Basis)

**For the Year Ended December 31, 2006**

---

	<u>Original Budget</u>	<u>Budget</u>	<u>Actual</u>	Variance with Final Budget Positive (Negative)
Revenues:				
Charges for Services	\$ 17,289,970	\$ 17,483,700	\$ 12,582,565	\$ (4,901,135)
Interest Income	<u>1,206,000</u>	<u>1,206,000</u>	<u>2,226,645</u>	<u>1,020,645</u>
Total Revenues	<u>18,495,970</u>	<u>18,689,700</u>	<u>14,809,210</u>	<u>(3,880,490)</u>
Expenses:				
Personal Services	9,668,050	9,407,370	8,627,597	779,773
Other	<u>7,416,570</u>	<u>7,859,300</u>	<u>6,281,606</u>	<u>1,577,694</u>
Total Expenses	<u>17,084,620</u>	<u>17,266,670</u>	<u>14,909,203</u>	<u>2,357,467</u>
Net Income (Loss)	\$ <u>1,411,350</u>	\$ <u>1,423,030</u>	\$ <u>(99,993)</u>	\$ <u>(1,523,023)</u>

Note: Although not required by law, an annual operating budget is adopted for management purposes.

# **Regional Income Tax Agency**

Notes to Supplementary Information

**December 31, 2006**

---

## **Note 1. Budgetary Process**

Although not required under the Ohio Revised Code, an annual operating budget, which lapses as of the end of the year, is adopted for management purposes. The budget is adopted for the enterprise fund on the same accounting basis used to reflect actual revenues and expenses. The Executive Director is authorized to expend the budget amounts; however, any change between the departments, line items or in the total amount budgeted for a particular fund requires the approval of the Board of Trustees of R.I.T.A.

# **Statistical Section**

**(Unaudited)**

## Statistical Section

This portion of the Agency's comprehensive annual financial report presents detailed information in a context for further understanding of the information in the financial statements, note disclosures and required supplementary information.

**Financial Trends** – This schedule contains trend information to assist the reader in understanding how the Agency has performed financially over time.

**Revenues** – These schedules contain information on the Agency's revenues.

**Operating Information** – These schedules contain information on Agency operations.

**Debt Capacity** – This schedule shows the Agency's Ratio of Debt.

**Economic and Demographic Information** – These schedules offer economic and demographic indicators for each municipality.

**Sources:** Unless otherwise noted, the information in these schedules is derived from the Comprehensive Annual Financial Reports for the relevant year.

# Regional Income Tax Agency

## Changes in Net Assets – Last Four Years

	<u>2006</u>	<u>2005</u>	<u>2004</u>	<u>2003</u>
Operating Revenues:				
Tax Collection Fees	\$ 11,462,953	\$ 11,645,263	\$ 12,249,244	\$ 11,884,291
Charges for Services and Other Revenues	<u>1,119,612</u>	<u>999,360</u>	<u>805,442</u>	<u>811,393</u>
Total Operating Revenues	<u>12,582,565</u>	<u>12,644,623</u>	<u>13,054,686</u>	<u>12,695,684</u>
Operating Expenses:				
Personal Services	8,627,597	8,208,534	8,729,464	8,023,512
Travel and Transportation	115,773	85,355	118,154	121,042
Office Rent and Maintenance	98,901	94,366	94,040	183,426
Equipment and Software Maintenance	640,165	616,605	653,344	452,651
Cost of Equipment Purchased For Members	150,146	86,498	368	5,139
Professional and Processing	1,799,750	1,488,940	1,441,458	1,599,172
Telephone and Utilities	165,493	190,713	215,945	225,034
Forms and Envelopes	312,327	306,546	173,307	323,914
Insurance	50,944	48,391	49,094	45,766
Miscellaneous Expenses	18,211	18,576	20,265	37,328
Material and Supplies	706,357	636,192	683,129	715,158
Depreciation and Amortization	<u>1,267,507</u>	<u>1,098,343</u>	<u>913,650</u>	<u>936,347</u>
Total Operating Expenses	<u>13,953,171</u>	<u>12,879,059</u>	<u>13,092,218</u>	<u>12,668,489</u>
Operating Income (Loss)	<u>(1,370,606)</u>	<u>(234,436)</u>	<u>(37,532)</u>	<u>27,195</u>
Non - Operating Revenues (Expenses):				
Interest Income	2,226,645	1,247,878	418,272	403,644
Interest Expense	(929,298)	(1,084,795)	(405,076)	(428,755)
Loss on Disposal of Capital Assets	<u>(26,734)</u>	<u>(16)</u>	<u>(712)</u>	<u>(2,790)</u>
Total Non - Operating Revenues (Expenses)	<u>1,270,613</u>	<u>163,067</u>	<u>12,484</u>	<u>(27,901)</u>
Change in Net Assets	(99,993)	(71,369)	(25,048)	(706)
Net Assets, Beginning of Year	<u>151,074</u>	<u>222,443</u>	<u>247,491</u>	<u>248,197</u>
Net Assets, End of Year	\$ <u><u>51,081</u></u>	\$ <u><u>151,074</u></u>	\$ <u><u>222,443</u></u>	\$ <u><u>247,491</u></u>



## Regional Income Tax Agency

### Revenue by Type – Last Ten Fiscal Years

	<u>2006</u>	<u>2005</u>	<u>2004</u>	<u>2003</u>	<u>2002</u>	<u>2001</u>	<u>2000</u>	<u>1999</u>	<u>1998</u>	<u>1997</u>
Tax Operating Revenues:										
Tax Collection Fees	\$ 11,462,953	\$ 11,645,263	\$ 12,249,244	\$ 11,884,291	\$ 10,481,831	\$ 7,074,998	\$ 4,612,317	\$ 3,799,159	\$ 3,083,965	\$ 2,800,207
Charges for Services and Other Services	<u>1,119,612</u>	<u>999,360</u>	<u>805,442</u>	<u>811,393</u>	<u>703,136</u>	<u>719,818</u>	<u>511,301</u>	<u>528,439</u>	<u>474,120</u>	<u>437,699</u>
Total Operating Revenues	12,582,565	12,644,623	13,054,686	12,695,684	11,184,967	7,794,816	5,123,618	4,327,598	3,558,085	3,237,906
Non-Operating Revenues:										
Interest Income	<u>2,226,645</u>	<u>1,247,878</u>	<u>418,272</u>	<u>403,644</u>	<u>694,655</u>	<u>1,644,822</u>	<u>2,584,782</u>	<u>1,878,970</u>	<u>1,923,547</u>	<u>1,715,760</u>
Total Revenues	\$ <u>14,809,210</u>	\$ <u>13,892,501</u>	\$ <u>13,472,958</u>	\$ <u>13,099,328</u>	\$ <u>11,879,622</u>	\$ <u>9,439,638</u>	\$ <u>7,708,400</u>	\$ <u>6,206,568</u>	\$ <u>5,481,632</u>	\$ <u>4,953,666</u>

SOURCE: R.I.T.A. accounting records

# Regional Income Tax Agency

Table of Municipal Income Tax Receipts – Last Ten Fiscal Years (Continued)

	2006	2005	2004	2003	2002	2001	2000	1999	1998	1997
Arlington Heights (A)	\$ 487,004	\$ 409,986	\$ 412,481	\$ 318,448	\$ -	\$ -	\$ -	\$ -	\$ -	\$ -
Ashville (A)	422,599	364,087	367,236	293,038	284,838	285,831	214,315	121,748	135,907	-
Aurora	9,438,468	8,492,888	8,835,008	8,061,004	5,464,240	5,588,485	5,482,449	4,903,958	4,613,196	4,065,554
Avon	7,839,956	6,920,540	6,233,184	6,003,837	4,341,119	2,676,128	2,302,999	1,898,535	1,719,507	1,465,381
Avon Lake	9,098,148	6,951,301	7,244,001	6,731,715	6,703,170	6,615,760	6,801,989	5,972,032	5,585,553	2,618,106
Bay Village	4,697,748	4,394,909	4,189,782	4,305,547	4,062,576	4,097,083	3,958,331	3,679,207	3,443,980	3,242,559
Beachwood	18,854,122	16,777,363	16,105,554	15,614,794	15,446,406	15,616,185	15,309,941	13,686,500	13,362,577	13,993,918
Beachwood East Jedd (A)	405,221	315,570	224,704	250,560	237,421	487,332	74,760	-	-	-
Beachwood West Jedd (A)	(708)	(3)	(305)	993	1,609	2,702	4,287	-	-	-
Bedford Heights	8,765,894	8,943,539	8,365,435	8,317,810	8,134,753	9,256,246	8,648,407	8,552,301	8,453,556	8,967,834
Bentleyville	927,298	772,729	812,263	961,017	784,618	832,449	754,140	639,770	663,363	698,199
Berea	10,134,502	9,068,671	9,141,736	8,577,174	8,674,811	8,709,248	8,715,217	7,832,988	6,813,677	6,336,502
Bexley	5,872,359	5,220,226	5,164,869	5,191,839	5,100,245	5,367,039	4,570,838	4,447,977	4,132,681	3,607,633
Boston Heights	561,237	472,769	402,130	376,473	352,660	356,147	325,043	232,605	195,280	164,792
Brady Lake	-	72	10,452	13,257	13,602	16,226	13,024	11,201	16,537	17,422
Brecksville	13,767,440	12,790,541	12,521,243	11,521,261	11,484,762	12,388,352	11,156,555	10,825,306	9,763,895	8,514,512
Broadview Heights	8,915,482	8,740,669	8,110,581	7,500,457	7,063,144	7,129,747	6,518,634	6,484,289	5,778,405	5,221,559
Brooklyn Heights	4,485,212	4,564,081	4,079,522	3,960,316	3,731,396	3,830,887	3,839,697	4,019,780	4,022,209	3,871,829
Campbell (A)	1,794,249	1,808,582	-	-	-	-	-	-	-	-
Cardington (A)	630,548	-	-	-	-	-	-	-	-	-
Cecil (A)	20,357	17,441	9,925	-	-	-	-	-	-	-
Cedarville (A)	432,185	442,950	388,123	368,248	-	-	-	-	-	-
Centerburg (A)	308,119	291,932	275,002	285,221	-	-	-	-	-	-
Chagrin Falls	2,695,863	2,541,099	2,394,881	2,371,750	2,328,445	2,461,744	2,330,019	2,342,701	2,222,508	2,166,839
Circleville (A)	3,990,345	3,981,679	4,214,050	2,162,291	-	-	-	-	-	-
Clayton (A)	2,069,313	1,871,855	-	-	-	-	-	-	-	-
Cuyahoga Heights	7,811,398	7,703,930	7,645,256	7,297,331	5,222,740	6,144,117	6,807,796	6,459,124	6,157,834	6,500,687
East Cleveland	6,630,915	6,522,439	6,626,103	7,651,447	6,781,992	7,105,718	6,852,297	4,816,657	4,580,887	4,376,386
East Palestine (A)	284,237	-	-	-	-	-	-	-	-	-
Elyria	22,110,092	20,360,722	20,479,169	19,086,332	18,403,641	20,300,452	18,904,282	18,277,567	17,285,571	16,509,379
Elyria Jedd (A)	399,754	428,760	458,426	95,304	-	-	-	-	-	-
Fairport Harbor (A)	687,089	679,233	582,802	555,214	-	-	-	-	-	-
Fairview Park	7,194,218	5,356,976	4,700,560	4,580,937	4,447,363	4,472,064	4,155,487	4,165,793	4,083,613	3,815,603
Fort Jennings (A)	75,931	74,437	74,464	76,279	39,528	-	-	-	-	-
Fremont (A)	7,702,960	7,791,146	-	-	-	-	-	-	-	-
Galena	147,786	119,145	100,404	143,312	104,979	108,153	98,262	76,982	79,445	16,661
Galion (A)	3,275,523	1,260,750	-	-	-	-	-	-	-	-
Garfield Heights	10,117,919	9,265,224	8,935,455	8,905,885	8,734,770	8,785,379	8,480,102	8,526,090	8,031,888	7,449,072
Girard (A)	3,506,729	3,586,521	-	-	-	-	-	-	-	-
Glenwillow	1,319,673	1,444,332	1,171,614	1,267,408	1,144,899	922,770	1,004,948	680,271	803,082	462,817
Grafton (A)	69,938	-	-	-	-	-	-	-	-	-
Grandview Heights (A)	4,652,001	3,140,619	2,739,117	3,342,406	3,232,081	3,593,972	3,792,821	3,538,895	2,893,057	-
Grove City (A)	16,790,862	15,257,975	5,629,606	-	-	-	-	-	-	-
Haskins (A)	173,998	142,756	122,570	-	-	-	-	-	-	-

Continued

# Regional Income Tax Agency

Table of Municipal Income Tax Receipts – Last Ten Fiscal Years (Continued)

	2006	2005	2004	2003	2002	2001	2000	1999	1998	1997
Highland Heights	\$ 6,298,831	\$ 5,742,843	\$ 6,122,085	\$ 6,329,961	\$ 6,219,328	\$ 6,200,741	\$ 6,248,852	\$ 6,220,961	\$ 5,890,509	\$ 4,343,568
Hudson	16,945,942	13,233,521	8,342,563	7,253,524	6,917,993	7,137,023	6,888,064	6,751,185	6,398,722	5,479,061
Hunting Valley (A)	(657)	(7,406)	(49,504)	3,914	417,013	383,540	615,552	599,331	-	-
Independence	20,735,779	18,799,401	19,462,008	18,104,154	17,149,369	18,364,277	18,140,108	17,400,456	17,297,918	16,191,386
Jewett (A)	48,957	58,085	-	-	-	-	-	-	-	-
Kirtland	2,862,367	2,793,146	2,544,784	2,386,087	2,622,354	2,033,147	1,916,331	1,864,880	1,723,355	1,619,680
LaGrange	626,433	675,677	554,952	605,677	587,792	751,022	626,357	548,006	456,238	465,261
Lakemore	787,664	836,136	785,565	738,092	697,626	701,644	685,874	694,300	663,748	627,893
Lakewood	530,933	15,110,209	15,841,273	15,816,234	17,253,672	16,093,018	14,624,618	12,923,110	12,422,431	11,726,217
Lockland	1,959,199	1,579,100	1,622,558	1,752,266	1,822,553	1,780,473	1,812,351	1,897,163	1,978,042	1,828,836
Lyndhurst	5,714,252	5,891,114	5,506,114	7,386,453	5,341,645	5,564,293	5,273,029	5,025,716	5,448,621	4,851,487
Macedonia (A)	7,049,982	6,386,466	1,402,742	-	-	-	-	-	-	-
Macedonia Northfield Jed (A)	158,519	144,576	20,495	-	-	-	-	-	-	-
Maineville (A)	263,414	212,019	163,204	75,990	7,492	-	-	-	-	-
Maple Heights	6,171,024	6,078,964	6,263,009	6,184,532	6,095,770	6,536,726	6,140,657	5,879,303	5,452,550	5,342,727
Martins Ferry (A)	1,103,246	1,052,582	1,028,954	1,027,803	643,079	-	-	-	-	-
Marysville (A)	-	582,523	6,215,610	5,981,792	5,770,975	-	-	-	-	-
Mayfield Heights	11,376,971	9,986,391	10,312,568	9,298,122	8,598,234	8,677,150	8,852,255	8,198,951	7,904,008	6,348,043
Mayfield Village	10,166,314	9,682,595	8,727,426	7,670,679	7,600,490	6,902,239	5,934,746	6,179,650	5,958,151	5,382,268
Mechanicsburg (A)	355,881	359,151	-	-	-	-	-	-	-	-
Middleburg Heights	13,700,623	12,498,286	12,768,169	12,741,649	12,167,139	12,514,175	12,569,270	11,843,642	10,743,002	6,344,927
Milan	265,326	225,314	286,280	316,439	279,882	238,728	219,323	237,827	205,591	191,491
Milford Center (A)	109,812	120,968	100,288	107,194	92,210	123,857	101,066	93,254	48,398	-
Minerva Park (A)	260,183	142,535	-	-	-	-	-	-	-	-
Mogadore	2,090,342	1,785,055	1,911,413	1,857,573	1,821,524	1,881,797	1,503,705	1,343,437	1,295,390	1,237,897
Moreland Hills	2,725,730	2,838,502	3,138,603	2,583,252	2,325,553	2,405,163	2,210,277	2,521,189	2,512,625	1,940,178
Mount Gilead (A)	-	118,768	730,270	735,100	762,999	848,532	346,824	-	-	-
Mount Sterling	567,711	550,859	518,129	605,070	640,415	660,489	682,820	615,627	554,408	541,371
New Albany	14,831,154	14,938,168	11,406,094	8,491,611	6,326,466	4,496,119	3,022,408	2,562,427	1,521,742	1,271,040
New Bloomington (A)	22,468	24,076	19,315	15,207	3,493	-	-	-	-	-
New Waterford (A)	24,962	-	-	-	-	-	-	-	-	-
Newburgh Heights	697,347	731,964	726,495	729,274	747,376	824,891	714,556	690,282	676,939	618,543
Newtown	1,066,024	908,331	891,131	1,011,215	860,111	1,081,732	1,011,380	974,675	937,648	9,940
North Lewisburg	188,909	196,673	196,699	190,163	189,864	193,246	184,973	181,975	182,184	166,724
North Olmsted	13,527,882	12,219,160	12,393,465	11,218,337	11,250,620	11,581,380	10,384,159	10,165,050	9,481,964	8,988,042
North Royalton (A)	8,400,349	7,969,666	7,810,621	7,626,388	7,276,995	7,611,612	6,495,643	-	-	-
Oakwood Village	3,591,212	3,391,487	3,391,704	3,164,863	3,085,394	3,126,813	3,058,141	3,072,958	3,109,151	2,669,909
Oberlin (A)	4,856,333	4,527,435	4,953,423	4,548,877	3,401,503	-	-	-	-	-
Olmsted Falls	2,516,094	2,548,446	2,422,215	2,422,673	2,401,890	2,266,339	2,071,072	1,989,119	1,882,537	1,699,709

Continued

# Regional Income Tax Agency

Table of Municipal Income Tax Receipts – Last Ten Fiscal Years (Continued)

	2006	2005	2004	2003	2002	2001	2000	1999	1998	1997
Orange	\$ 2,617,842	\$ 2,546,028	\$ 2,483,888	\$ 2,362,669	\$ 2,151,335	\$ 2,211,599	\$ 1,941,690	\$ 2,035,859	\$ 1,789,555	\$ 1,732,340
Orange Chagrin Highland										
Jedd (A)	238,534	172,155	184,863	135,343	151,687	48,608	49,073	-	-	-
Ottawa	1,143,938	1,128,203	1,116,901	1,454,384	1,604,995	1,544,661	1,775,889	1,705,193	1,657,050	177,796
Pepper Pike	4,018,878	4,000,337	3,825,487	3,660,415	3,402,408	3,712,518	3,616,223	3,391,847	3,386,169	3,431,241
Piketon (A)	341,988	35,521	-	-	-	-	-	-	-	-
Plain City	878,815	874,202	860,028	831,993	762,515	601,232	567,304	544,133	494,703	470,292
Plymouth (A)	170,352	145,029	128,992	127,921	133,322	29,733	-	-	-	-
Powell	3,656,776	3,101,343	2,838,732	2,470,689	2,572,880	2,279,293	1,993,122	1,866,089	1,496,480	1,377,631
Powhatan Point (A)	214,469	-	-	-	-	-	-	-	-	-
Reminderville	1,106,036	1,005,113	953,890	900,024	764,907	670,310	623,810	579,310	398,653	365,043
Reminderville Twins Jedd(A)	2,742,410	2,814,108	2,752,743	1,562,914	-	-	-	-	-	-
Reynoldsburg	9,353,718	8,626,186	8,727,145	9,748,253	7,616,845	9,289,276	9,481,422	8,413,084	7,172,374	5,959,704
Richmond Heights	4,521,017	4,325,010	3,995,697	4,403,427	4,036,489	4,178,336	3,901,797	3,519,985	3,397,120	2,955,246
Richwood	436,738	385,138	312,812	195,136	173,120	163,110	163,836	166,252	160,466	140,359
Ridgeway (A)	30,762	24,753	25,433	14,498	40	-	-	-	-	-
Riverside	4,394,371	4,481,199	4,221,231	4,195,122	4,108,880	4,114,665	2,929,139	2,548,948	2,579,935	2,355,571
Sabina (A)	356,839	341,217	62,167	71,353	370,841	94,135	-	-	-	-
Saint Paris	250,423	236,637	236,891	228,372	224,699	228,198	252,788	241,663	245,841	89,692
Salineville	172,276	175,890	159,495	181,021	186,969	172,899	167,933	176,716	131,656	94,784
Sandusky (A)	7,169,082	7,058,309	6,857,865	7,224,771	-	-	-	-	-	-
Seven Hills	4,391,546	4,157,764	4,353,566	4,358,167	4,164,748	4,274,161	4,449,611	4,180,028	3,829,752	3,784,418
Shaker Heights	19,910,669	19,808,975	17,303,875	24,202,995	18,775,824	18,979,360	17,066,236	17,493,945	16,784,301	15,534,324
Shawnee Hills	275,789	215,783	236,838	194,600	191,689	173,700	156,452	142,284	128,200	120,378
Sheffield Lake (A)	1,467,844	1,424,791	1,629,567	257,996	-	-	-	-	-	-
Sheffield Village	2,440,675	2,256,659	2,191,320	2,423,324	1,564,814	1,268,642	1,309,299	1,224,643	1,021,930	1,057,513
Sherwood (A)	85,544	60,932	20,156	-	-	-	-	-	-	-
Silver Lake	457,833	431,161	432,554	417,259	357,302	414,610	385,577	394,968	386,214	374,649
South Euclid	6,782,298	5,561,115	5,333,268	5,730,073	5,718,510	5,736,905	5,336,643	5,350,100	5,310,758	4,817,888
South Solon	29,817	34,335	28,563	23,817	18,947	26,878	42,002	21,694	35,240	5,688
Streetsboro	6,348,250	5,795,963	5,156,778	5,037,955	4,573,064	4,610,661	4,400,940	4,220,617	3,838,485	3,436,809
Stuebenville	8,615,422	8,166,069	8,011,866	8,605,455	8,376,878	7,695,389	8,366,631	4,758,637	4,537,816	4,402,893
Strongsville	27,338,412	24,575,686	21,118,155	18,631,219	17,934,416	18,670,908	17,464,177	16,252,376	15,402,382	14,878,164
Sunbury (A)	1,703,603	1,516,496	1,496,267	1,418,580	1,153,249	1,017,569	881,688	937,443	-	-
Tontogany (A)	15,710	-	-	-	-	-	-	-	-	-
Toronto	2,330,542	1,254,023	1,207,811	1,169,159	1,188,147	1,158,804	1,075,264	1,167,268	1,314,685	1,131,653
Uhrichsville (A)	330,682	-	-	-	-	-	-	-	-	-
University Heights	6,210,713	5,574,742	4,895,792	4,970,319	4,963,337	4,782,707	4,300,538	4,292,619	4,142,512	3,792,347
Upper Arlington	12,662,119	13,539,189	11,845,486	12,264,988	12,397,663	13,717,001	11,464,385	11,951,158	8,582,633	8,015,046
Urbancrest (A)	463,860	419,054	308,373	167,350	-	-	-	-	-	-
Valley View	7,859,314	8,369,946	8,059,175	8,265,868	7,814,541	8,155,098	6,956,588	7,376,813	6,485,224	5,810,763

Continued

## Regional Income Tax Agency

Table of Municipal Income Tax Receipts – Last Ten Fiscal Years (Continued)

	2006	2005	2004	2003	2002	2001	2000	1999	1998	1997
Vermilion (A)	\$ 1,199,940	\$ 1,194,264	\$ 1,163,213	\$ 1,152,282	\$ 1,211,700	\$ 1,143,966	\$ 1,165,393	\$ 216,033	\$ -	\$ -
Wakeman	136,052	125,533	140,268	118,592	114,497	132,938	129,744	109,982	101,937	88,096
Walton Hills	4,348,534	4,082,194	4,411,056	4,445,129	3,299,858	2,285,189	2,530,522	2,542,781	2,313,301	2,332,288
Wellston (A)	994,647	764,180	735,874	762,909	651,175	239,894	-	-	-	-
Wellsville (A)	474,371	365,549	400,070	-	-	-	-	-	-	-
West Elkton (A)	16,805	-	-	-	-	-	-	-	-	-
Westlake	17,808,494	16,314,506	15,507,647	14,927,199	15,005,585	14,879,861	13,979,628	13,321,028	12,977,156	11,596,214
Willowick	2,290,847	2,292,818	2,119,653	2,212,622	2,133,356	2,166,869	2,083,067	2,085,456	2,067,897	1,940,813
Winterville	784,297	707,250	708,392	693,369	665,614	609,902	598,457	544,027	517,526	537,105
Woodmere	1,658,698	1,607,405	1,642,328	1,464,661	1,313,201	1,511,487	1,406,439	1,491,122	1,526,824	1,313,603
Woodstock (A)	5,411	-	-	-	-	-	-	-	-	-
Worthington (A)	15,076,007	13,915,446	13,473,720	11,477,756	4,362,377	-	-	-	-	-
Yellow Springs (A)	1,264,926	1,262,798	1,433,848	1,340,900	-	-	-	-	-	-
Youngstown (A)	50,269,440	-	-	-	-	-	-	-	-	-
Totals	\$ <u>622,025,867</u>	\$ <u>541,375,463</u>	\$ <u>492,978,422</u>	\$ <u>471,667,088</u>	\$ <u>419,885,152</u>	\$ <u>411,035,925</u>	\$ <u>386,966,066</u>	\$ <u>358,277,676</u>	\$ <u>333,798,855</u>	\$ <u>298,089,793</u>

Note: Above amounts are the net collections for the period January 1 to December 31 of the respective years.

(A) Municipality joined the Regional Council of Governments during the year in which tax collections began. All years prior to joining are accordingly left blank.

## Regional Income Tax Agency

### Operating Expenses by Type – Last Ten Fiscal Years

	<u>2006</u>	<u>2005</u>	<u>2004</u>	<u>2003</u>	<u>2002</u>	<u>2001</u>	<u>2000</u>	<u>1999</u>	<u>1998</u>	<u>1997</u>
Tax Operating Expenses:										
Personal Services	\$ 8,627,597	\$ 8,208,534	\$ 8,729,464	\$ 8,023,512	\$ 7,234,950	\$ 5,708,292	\$ 4,374,676	\$ 3,863,162	\$ 3,316,391	\$ 3,002,145
Travel and Transportation	115,773	85,355	118,154	121,042	203,099	97,350	58,898	64,553	37,725	48,356
Office Rent and Maintenance	98,901	94,366	94,040	183,426	180,878	177,478	246,740	114,173	199,257	311,192
Equipment and Software Maintenance	640,165	616,605	653,344	452,651	519,390	284,099	202,333	197,776	163,780	121,250
Cost of Equipment Purchased For Members	150,146	86,498	368	5,139	9,957	9,384	5,013	15,834	13,470	20,403
Professional and Processing	1,799,750	1,488,940	1,441,458	1,599,172	1,097,635	1,190,505	1,289,330	587,828	692,357	504,488
Telephone and Utilities	165,493	190,713	215,945	225,034	202,227	207,163	187,893	176,685	175,605	159,252
Forms & Envelopes	312,327	306,546	173,307	323,914	429,642	467,687	292,481	261,950	187,701	187,707
Insurance	50,944	48,391	49,094	45,766	43,365	40,616	33,062	38,435	38,231	38,763
Miscellaneous Expenses	18,211	18,576	20,265	37,328	29,197	41,081	43,247	20,981	46,302	23,235
Material and Supplies	706,357	636,192	683,129	715,158	675,394	620,923	563,337	486,255	461,027	440,872
Depreciation and Amortization	<u>1,267,507</u>	<u>1,098,343</u>	<u>913,650</u>	<u>936,347</u>	<u>768,132</u>	<u>486,038</u>	<u>346,568</u>	<u>315,039</u>	<u>156,221</u>	<u>59,877</u>
Total Operating Expenses	13,953,171	12,879,059	13,092,218	12,668,489	11,393,866	9,330,616	7,643,578	6,142,671	5,488,067	4,917,540
Non-Operating Expense:										
Net Interest Expense	<u>929,298</u>	<u>1,084,795</u>	<u>405,076</u>	<u>428,755</u>	<u>486,366</u>	<u>134,840</u>	<u>-</u>	<u>-</u>	<u>-</u>	<u>-</u>
Total Expenses	\$ <u>14,882,469</u>	\$ <u>13,963,854</u>	\$ <u>13,497,294</u>	\$ <u>13,097,244</u>	\$ <u>11,880,232</u>	\$ <u>9,465,456</u>	\$ <u>7,643,578</u>	\$ <u>6,142,671</u>	\$ <u>5,488,067</u>	\$ <u>4,917,540</u>

SOURCE: R.I.T.A. accounting records

## Regional Income Tax Agency

### Operating Indicators – Last Ten Fiscal Years

---

	<u>2006</u>	<u>2005</u>	<u>2004</u>	<u>2003</u>	<u>2002</u>	<u>2001</u>	<u>2000</u>	<u>1999</u>	<u>1998</u>	<u>1997</u>
Number of cities	128	118	110	104	97	89	86	85	81	78
Net Cost of Collections Percentage	1.84%	2.16%	2.49%	2.52%	2.50%	1.72%	1.19%	1.06%	0.92%	0.95%
Net distributions (A)	\$ <u>583,585,191</u>	\$ <u>521,470,923</u>	\$ <u>465,097,577</u>	\$ <u>453,876,568</u>	\$ <u>410,411,220</u>	\$ <u>403,337,929</u>	\$ <u>381,077,887</u>	\$ <u>358,277,676</u>	\$ <u>333,820,641</u>	\$ <u>296,512,963</u>
Number of employees (B)	128	129	136	132	130	116	100	95	82	80

Notes:

(A) Represents the distributions to the cities during the respective years.

(B) Represents the number of full-time employees at December 31<sup>st</sup>.

# Regional Income Tax Agency

Membership as of December 31, 2006 Table of Census Data

	<u>2000 Population</u>	<u>Calendar Year 2000 Per capita Income</u>
<u>Belmont County</u>		
Martins Ferry	7,226	\$ 16,672
Powhatan Point	1,744	14,570
<u>Champaign County</u>		
Mechanicsburg	1,744	16,685
North Lewisburg	1,588	18,461
St. Paris	1,998	16,811
Woodstock	317	24,633
<u>Clinton County</u>		
Sabina	2,780	16,481
<u>Columbiana County</u>		
East Palestine	4,917	16,243
New Waterford	1,391	16,239
Salineville	1,397	13,895
Wellsville	4,133	14,335
<u>Crawford County</u>		
Galion	11,341	16,113
<u>Cuyahoga County</u>		
Bay Village	16,087	35,318
Beachwood	12,186	40,509
Bedford Heights	11,375	21,791
Bentleyville	947	72,392
Berea	18,970	21,647
Brecksville	13,382	37,838
Broadview Heights	15,967	29,440
Brooklyn Heights	1,558	27,012
Chagrin Falls	4,024	42,885
Cuyahoga Heights	599	21,446
East Cleveland	27,217	12,602
Fairview Park	17,572	27,662
Garfield Heights	30,734	18,988
Glenwillow	449	19,942
Highland Heights	8,082	31,184
Hunting Valley	735	144,281
Independence	7,109	26,447
Lakewood	56,646	23,945
Lyndhurst	15,279	28,206
Maple Heights	26,156	18,676
Mayfield Heights	19,386	24,392
Mayfield Village	3,435	36,360

Continued



# Regional Income Tax Agency

Membership as of December 31, 2006 Table of Census Data (continued)

	2000 <u>Population</u>	Calendar Year 2000 Per capita <u>Income</u>
<u>Cuyahoga County (continued)</u>		
Middleburg Heights	15,542	\$ 25,201
Moreland Hills	3,298	72,001
Newburgh Heights	2,389	18,636
North Olmsted	34,113	24,329
North Royalton	28,648	26,610
Oakwood Village	3,667	15,273
Olmsted Falls	7,962	25,716
Orange	3,236	46,296
Pepper Pike	6,040	71,255
Richmond Heights	10,944	25,738
Seven Hills	12,080	25,014
Shaker Heights	29,405	41,354
South Euclid	23,537	22,383
Strongsville	43,858	29,722
University Heights	14,146	26,949
Valley View	2,179	26,560
Walton Hills	2,400	26,405
Westlake	31,719	37,142
Woodmere	828	22,703
<u>Defiance County</u>		
Sherwood	801	16,212
<u>Delaware County</u>		
Galena	305	20,163
Powell	6,247	46,257
Shawnee Hills	419	25,266
Sunbury	2,630	18,861
<u>Erie County</u>		
Milan	1,445	23,143
Sandusky	27,844	18,111
Vermilion	10,927	23,635
<u>Franklin County</u>		
Bexley	13,203	37,375
Grandview Heights	6,695	27,495
Grove City	27,075	22,305
Minerva Park	1,288	29,629
New Albany	3,711	62,131
Reynoldsburg	32,069	23,388
Upper Arlington	33,686	42,025
Urbancrest	868	10,003
Worthington	14,125	34,495

Continued

# Regional Income Tax Agency

Membership as of December 31, 2006 Table of Census Data (continued)

	<u>2000 Population</u>	<u>Calendar Year 2000 Per capita Income</u>
<u>Greene County</u>		
Cedarville	3,828	\$ 9,499
Yellow Springs	3,761	27,062
<u>Hamilton County</u>		
Arlington Heights	899	17,683
Lockland	3,707	15,661
Newtown	2,420	32,590
<u>Hardin County</u>		
Ridgeway	354	18,537
<u>Harrison County</u>		
Jewett	784	12,158
<u>Huron County</u>		
Plymouth	1,852	15,474
Wakeman	951	18,559
<u>Jackson County</u>		
Wellston	6,078	13,476
<u>Jefferson County</u>		
Steubenville	19,015	17,830
Toronto	5,676	15,761
Wintersville	4,067	18,941
<u>Knox County</u>		
Centerburg	1,432	16,764
<u>Lake County</u>		
Fairport Harbor	3,180	20,722
Kirtland	6,670	32,148
Willowick	14,361	22,053
<u>Lorain County</u>		
Avon	11,446	28,334
Avon Lake	18,145	32,336
Elyria	55,953	19,344
Grafton	2,302	19,584
LaGrange	1,815	19,465
Oberlin	8,195	20,704
Sheffield Lake	9,371	20,219
Sheffield Village	2,949	25,218

Continued

## Regional Income Tax Agency

Membership as of December 31, 2006 Table of Census Data (continued)

	<u>2000 Population</u>	<u>Calendar Year 2000 Per capita Income</u>
<u>Marion County</u>		
New Bloomington	548	\$ 13,707
<u>Madison County</u>		
Mount Sterling	1,865	16,138
Plain City	2,832	20,815
South Solon	405	15,152
<u>Mahoning County</u>		
Campbell	9,460	17,981
Youngstown	82,026	13,293
<u>Montgomery County</u>		
Clayton	13,347	26,569
Riverside	23,545	18,702
<u>Morrow County</u>		
Cardington	80,806	14,057
Mount Gilead	3,290	19,064
<u>Paulding County</u>		
Cecil	216	12,687
<u>Pickaway County</u>		
Ashville	3,174	16,645
Circleville	13,485	17,220
<u>Pike County</u>		
Piketon	1,907	11,599
<u>Portage County</u>		
Aurora	13,556	35,537
Brady Lake	513	19,357
Streetsboro	12,311	21,764
<u>Preble County</u>		
West Elkton	194	16,676
<u>Putnam County</u>		
Fort Jennings	432	20,169
Ottawa	4,367	22,476
<u>Sandusky County</u>		
Fremont	17,375	16,014

Continued

# Regional Income Tax Agency

Membership as of December 31, 2006 Table of Census Data (continued)

	<u>2000 Population</u>	<u>Calendar Year 2000 Per capita Income</u>
<u>Summit County</u>		
Boston Heights	1,186	\$ 36,960
Hudson	22,439	40,915
Lakemore	2,561	14,837
Macedonia	9,224	27,739
Mogadore	3,893	20,965
Reminderville	2,347	24,477
Silver Lake	3,019	35,614
<u>Trumbull County</u>		
Girard	10,900	17,077
<u>Tuscarawas County</u>		
Uhrichsville	5,662	13,144
<u>Union County</u>		
Marysville	15,942	19,127
Milford Center	626	18,346
Richwood	2,156	16,799
<u>Warren County</u>		
Maineville	885	24,054
<u>Wood County</u>		
Haskins	638	17,696
Tontogany	364	17,578

Source: Per Capita Income  
Bureau of the Census; Census 2000 Social, Economic and Housing Profiles, Table DP-3 Profile of Selected Economic Characteristics

Population  
U.S. Census Bureau, Census 2000 Summary File 3

# Regional Income Tax Agency

Table of Municipal Income Tax Rates, Credits and Limits – Last Ten Fiscal Years

		2006	2005	2004	2003	2002	2001	2000	1999	1998	1997
Arlington Heights	Tax Rate	2.10%	2.10%	2.10%	2.10%	-	-	-	-	-	-
	Tax Credit	100	100	100	100	-	-	-	-	-	-
	Credit Limit	2.10	2.10	2.10	2.10	-	-	-	-	-	-
Ashville	Tax Rate	0.50	0.50	0.50	0.50	0.50%	0.50%	0.50%	0.29%	0.87%	-
	Tax Credit	0	0	0	0	0	0	0	0	50	-
	Credit Limit	0.50	0.50	0.50	0.50	0.50	0.50	0.50	0.29	0.87	-
Aurora	Tax Rate	2.00	2.00	2.00	2.00	1.00	1.00	1.00	1.00	1.00	1.00%
	Tax Credit	100	100	100	100	25	50	50	50	50	50
	Credit Limit	2.00	2.00	2.00	2.00	1.00	1.00	1.00	1.00	1.00	1.00
Avon	Tax Rate	1.50	1.50	1.50	1.50	1.50	1.50	1.00	1.00	1.00	-
	Tax Credit	100	100	100	100	100	100	100	100	100	100
	Credit Limit	1.25	1.25	1.25	1.25	1.25	1.00	1.00	1.00	1.00	1.00
Avon Lake	Tax Rate	1.50	1.50	1.50	1.50	1.50	1.50	1.50	1.50	1.50	1.50
	Tax Credit	100	100	100	100	100	100	100	100	100	100
	Credit Limit	1.50	1.50	1.50	1.50	1.50	1.50	1.50	1.50	1.50	1.50
Bay Village	Tax Rate	1.50	1.50	1.50	1.50	1.50	1.50	1.50	1.50	1.50	1.50
	Tax Credit	100	100	100	100	100	100	100	100	100	100
	Credit Limit	1.00	1.00	1.00	1.00	1.00	1.00	1.00	1.00	1.00	1.00
Beachwood	Tax Rate	1.50	1.50	1.50	1.50	1.50	1.50	1.50	1.50	1.50	1.50
	Tax Credit	100	100	100	100	100	100	100	100	100	100
	Credit Limit	1.50	1.50	1.50	1.50	1.50	1.50	1.50	1.50	1.50	1.50
Beachwood East Jedd	Tax Rate	1.50	1.50	1.50	1.50	1.50	1.50	1.50	-	-	-
Beachwood West Jedd	Tax Rate	1.50	1.50	1.50	1.50	1.50	1.50	1.50	-	-	-
Bedford Heights	Tax Rate	2.00	2.00	2.00	2.00	2.00	2.00	2.00	2.00	2.00	2.00
	Tax Credit	100	100	100	100	100	100	100	100	100	100
	Credit Limit	2.00	2.00	2.00	2.00	2.00	2.00	2.00	2.00	2.00	2.00
Bentleyville	Tax Rate	1.00	1.00	1.00	1.00	1.00	1.00	1.00	1.00	1.00	1.00
	Tax Credit	25	25	25	25	25	25	25	25	25	25
	Credit Limit	1.00	1.00	1.00	1.00	1.00	1.00	1.00	1.00	1.00	1.00
Berea	Tax Rate	2.00	2.00	2.00	2.00	2.00	2.00	2.00	2.00	2.00	2.00
	Tax Credit	100	100	100	100	100	100	100	100	100	100
	Credit Limit	1.50	1.50	1.50	1.50	1.50	1.50	1.50	1.50	1.50	1.50

Continued

# Regional Income Tax Agency

Table of Municipal Income Tax Rates, Credits and Limits – Last Ten Fiscal Years (continued)

		2006	2005	2004	2003	2002	2001	2000	1999	1998	1997
Bexley	Tax Rate	2.00%	2.00%	2.00%	2.00%	2.00%	2.00%	2.00%	2.00%	2.00%	2.00%
	Tax Credit	80	80	80	80	80	80	80	80	80	80
	Credit Limit	2.00	2.00	2.00	2.00	2.00	2.00	2.00	2.00	2.00	2.00
Boston Heights	Tax Rate	2.00	2.00	1.50	1.50	1.50	1.50	1.50	1.25	1.00	1.00
	Tax Credit	100	100	100	100	100	100	100	100	100	100
	Credit Limit	2.00	2.00	1.50	1.50	1.50	1.50	1.50	1.25	1.00	1.00
Brady Lake	Tax Rate	1.00	1.00	1.00	1.00	1.00	1.00	1.00	1.00	1.00	1.00
	Tax Credit	100	100	100	100	100	100	100	100	100	100
	Credit Limit	1.00	1.00	1.00	1.00	1.00	1.00	1.00	1.00	1.00	1.00
Brecksville	Tax Rate	2.00	2.00	2.00	2.00	2.00	2.00	2.00	2.00	2.00	2.00
	Tax Credit	100	100	100	100	100	100	100	100	100	100
	Credit Limit	2.00	2.00	2.00	2.00	2.00	2.00	2.00	2.00	2.00	2.00
Broadview Heights	Tax Rate	2.00	2.00	2.00	2.00	2.00	2.00	2.00	2.00	2.00	2.00
	Tax Credit	75	75	75	75	75	75	75	75	75	75
	Credit Limit	2.00	2.00	2.00	2.00	2.00	2.00	2.00	2.00	2.00	2.00
Brooklyn Heights	Tax Rate	2.00	2.00	2.00	2.00	2.00	2.00	2.00	2.00	2.00	2.00
	Tax Credit	100	100	100	100	100	100	100	100	100	100
	Credit Limit	2.00	2.00	2.00	2.00	2.00	2.00	2.00	2.00	2.00	2.00
Campbell	Tax Rate	2.50	2.50	-	-	-	-	-	-	-	-
	Tax Credit	100	100	-	-	-	-	-	-	-	-
	Credit Limit	2.50	2.50	-	-	-	-	-	-	-	-
Cardington	Tax Rate	1.00	-	-	-	-	-	-	-	-	-
	Tax Credit	100	-	-	-	-	-	-	-	-	-
	Credit Limit	1.00	-	-	-	-	-	-	-	-	-
Cecil	Tax Rate	1.00	1.00	1.00	-	-	-	-	-	-	-
	Tax Credit	50	50	100	-	-	-	-	-	-	-
	Credit Limit	1.00	1.00	1.00	-	-	-	-	-	-	-
Cedarville	Tax Rate	1.00	1.00	1.00	1.00	-	-	-	-	-	-
	Tax Credit	100	100	100	100	-	-	-	-	-	-
	Credit Limit	1.00	1.00	1.00	1.00	-	-	-	-	-	-
Centerburg	Tax Rate	1.00	1.00	1.00	1.00	-	-	-	-	-	-
	Tax Credit	50	50	50	50	-	-	-	-	-	-
	Credit Limit	1.00	1.00	1.00	1.00	-	-	-	-	-	-

Continued

# Regional Income Tax Agency

Table of Municipal Income Tax Rates, Credits and Limits – Last Ten Fiscal Years (continued)

		2006	2005	2004	2003	2002	2001	2000	1999	1998	1997
Chagrin Falls	Tax Rate	1.50%	1.50%	1.50%	1.50%	1.50%	1.50%	1.50%	1.50%	1.50%	1.50%
	Tax Credit	75	75	75	75	75	75	75	75	75	75
	Credit Limit	1.50	1.50	1.50	1.50	1.50	1.50	1.50	1.50	1.50	1.50
Circleville	Tax Rate	1.50	1.50	1.50	1.50	-	-	-	-	-	-
	Tax Credit	100	100	100	100	-	-	-	-	-	-
	Credit Limit	1.50	1.50	1.50	1.50	-	-	-	-	-	-
Clayton	Tax Rate	1.50	1.50	1.50	-	-	-	-	-	-	-
	Tax Credit	100	100	100	-	-	-	-	-	-	-
	Credit Limit	1.50	1.50	1.50	-	-	-	-	-	-	-
Cuyahoga Heights	Tax Rate	2.00	2.00	2.00	2.00	1.50/2.00	1.50	1.50	1.50	1.50	1.50
	Tax Credit	100	100	100	100	100	100	100	100	100	100
	Credit Limit	2.00	2.00	2.00	2.00	1.50/2.00	1.50	1.50	1.50	1.50	1.50
East Cleveland	Tax Rate	2.00	2.00	2.00	2.00	2.00	2.00	2.00	2.00	2.00	2.00
	Tax Credit	-	-	-	-	-	-	-	-	-	-
	Credit Limit	1.00	1.00	1.00	1.00	1.00	1.00	1.00	1.00	1.00	1.00
East Palestine	Tax Rate	1.00	-	-	-	-	-	-	-	-	-
	Tax Credit	-	-	-	-	-	-	-	-	-	-
	Credit Limit	1.00	-	-	-	-	-	-	-	-	-
Elyria	Tax Rate	1.75	1.75	1.75	1.75	1.75	1.75	1.75	1.75	1.75	1.75
	Tax Credit	100	100	100/50	100	100	100	100	100	100	100
	Credit Limit	1.75	1.75	1.75	1.75	1.75	1.75	1.75	1.75	1.75	1.75
Elyria Jedd Fairport Harbor	Tax Rate	2.00	2.00	1.75	1.75	-	-	-	-	-	-
	Tax Credit	100	100	100	100	-	-	-	-	-	-
	Credit Limit	2.00	2.00	2.00	2.00	-	-	-	-	-	-
Fairview Park	Tax Rate	1.875	1.875	1.50	1.50	1.50	1.50	1.50	1.50	1.50	1.50
	Tax Credit	75	75	75	75	75	75	75	75	75	75
	Credit Limit	1.25	1.25	1.25	1.25	1.25	1.25	1.25	1.25	1.25	1.25
Fort Jennings	Tax Rate	1.00	1.00	1.00	1.00	1.00	-	-	-	-	-
	Tax Credit	100	100	100	100	100	-	-	-	-	-
	Credit Limit	1.00	1.00	1.00	1.00	1.00	-	-	-	-	-
Fremont	Tax Rate	1.50	1.50	-	-	-	-	-	-	-	-
	Tax Credit	100	100	-	-	-	-	-	-	-	-
	Credit Limit	1.50	1.50	-	-	-	-	-	-	-	-

Continued

# Regional Income Tax Agency

Table of Municipal Income Tax Rates, Credits and Limits – Last Ten Fiscal Years (continued)

		<u>2006</u>	<u>2005</u>	<u>2004</u>	<u>2003</u>	<u>2002</u>	<u>2001</u>	<u>2000</u>	<u>1999</u>	<u>1998</u>	<u>1997</u>
Galena	Tax Rate	1.00%	1.00%	1.00%	1.00%	1.00%	1.00%	1.00%	1.00%	1.00%	1.00%
	Tax Credit	-	-	-	-	-	-	-	-	-	-
	Credit Limit	1.00	1.00	1.00	1.00	1.00	1.00	1.00	1.00	1.00	1.00
Galion	Tax Rate	1.75	1.50	-	-	-	-	-	-	-	-
	Tax Credit	100	100	-	-	-	-	-	-	-	-
	Credit Limit	1.00	1.00	-	-	-	-	-	-	-	-
Garfield Heights	Tax Rate	2.00	2.00	2.00	2.00	2.00	2.00	2.00	2.00	2.00	2.00
	Tax Credit	100	100	100	100	100	100	100	100	100	100
	Credit Limit	2.00	2.00	2.00	2.00	2.00	2.00	2.00	1.00	1.00	1.00
Girard	Tax Rate	2.00	2.00	1.00	1.00	-	-	-	-	-	-
	Tax Credit	100	100	-	-	-	-	-	-	-	-
	Credit Limit	2.00	2.00	-	-	-	-	-	-	-	-
Glenwillow	Tax Rate	2.00	2.00	2.00	1.00	1.00	1.00	1.00	1.00	-	-
	Tax Credit	100	100	100	100	100	100	100	100	100	100
	Credit Limit	2.00	2.00	2.00	2.00	2.00	2.00	-	-	-	-
Grafton	Tax Rate	1.50	-	-	-	-	-	-	-	-	-
	Tax Credit	100	-	-	-	-	-	-	-	-	-
	Credit Limit	1.50	-	-	-	-	-	-	-	-	-
Grandview Heights	Tax Rate	2.25	2.25	2.00	2.00	2.00	2.00	2.00	2.00	2.00	-
	Tax Credit	100	100	100	100	100	100	100	100	100	-
	Credit Limit	2.00	2.00	2.00	2.00	2.00	2.00	2.00	2.00	2.00	-
Grove City	Tax Rate	2.00	2.00	2.00	-	-	-	-	-	-	-
	Tax Credit	100	100	100	-	-	-	-	-	-	-
	Credit Limit	2.00	2.00	2.00	-	-	-	-	-	-	-
Haskins	Tax Rate	1.00	1.00	1.00	1.00	-	-	-	-	-	-
	Tax Credit	50	50	50	50	-	-	-	-	-	-
	Credit Limit	1.00	1.00	1.00	1.00	-	-	-	-	-	-
Highland Heights	Tax Rate	1.50	1.50	1.50	1.50	1.50	1.50	1.50	1.50	1.50	1.50
	Tax Credit	100	100	100	100	100	100	100	100	100	100
	Credit Limit	1.50	1.50	1.50	1.50	1.50	1.50	1.50	1.50	1.50	1.50
Hudson	Tax Rate	2.00	2.00	1.00	1.00	1.00	-	-	-	-	-
	Tax Credit	100	100	100	100	100	100	100	-	-	-
	Credit Limit	2.00	2.00	1.00	1.00	1.00	1.00	1.00	1.00	1.00	1.00

Continued



# Regional Income Tax Agency

Table of Municipal Income Tax Rates, Credits and Limits – Last Ten Fiscal Years (continued)

		2006	2005	2004	2003	2002	2001	2000	1999	1998	1997
Hunting Valley	Tax Rate	-	-	-	0.75%	0.75%	0.75%	0.75%	1.00%	-	-
	Tax Credit	-	-	-	75	75	75	50	50	-	-
	Credit Limit	-	-	-	0.75	0.75	0.75	0.75	1.00	-	-
Independence	Tax Rate	2.00%	2.00%	2.00%	2.00	2.00	2.00	2.00	2.00	2.00%	2.00%
	Tax Credit	100	100	100	100	100	100	100	100	100	100
	Credit Limit	2.00	2.00	2.00	2.00	2.00	2.00	2.00	2.00	2.00	2.00
Jewett	Tax Rate	1.00	1.00	-	-	-	-	-	-	-	-
	Tax Credit	100	100	-	-	-	-	-	-	-	-
	Credit Limit	1.00	1.00	-	-	-	-	-	-	-	-
Kirtland	Tax Rate	2.00	2.00	2.00	1.00	1.00	1.00	1.00	1.00	1.00	1.00
	Tax Credit	100	100	100	25	25	25	25	25	25	25
	Credit Limit	1.75	1.75	1.75	1.00	1.00	1.00	1.00	1.00	1.00	1.00
LaGrange	Tax Rate	1.50	1.50	1.50	1.50	1.50	1.50	1.50	1.50	1.50	1.50
	Tax Credit	100	100	100	100	100	100	100	100	100	100
	Credit Limit	1.50	1.50	1.50	1.50	1.50	1.50	1.50	1.50	1.50	1.50
Lakemore	Tax Rate	2.00	2.00	2.00	2.00	2.00	2.00	2.00	2.00	2.00	2.00
	Tax Credit	100	100	100	100	100	100	100	100	100	100
	Credit Limit	2.00	2.00	2.00	2.00	2.00	2.00	2.00	2.00	2.00	2.00
Lakewood	Tax Rate	-	1.50	1.50	1.50	1.50	1.50	1.50	1.50	1.50	1.50
	Tax Credit	-	50	50	50	50	50	50	50	50	50
	Credit Limit	-	1.00	1.00	1.00	1.00	1.00	1.00	1.00	1.00	1.00
Lockland	Tax Rate	2.10	2.10	2.10	2.10	2.10	2.10	2.10	2.10	2.10	2.10
	Tax Credit	100	100	100	100	100	100	100	100	100	100
	Credit Limit	2.10	2.10	2.10	2.10	2.10	2.10	2.10	2.10	2.10	2.10
Lyndhurst	Tax Rate	1.50	1.50	1.50	1.50	1.50	1.50	1.50	1.50	1.50	1.50
	Tax Credit	50	50	50	50	50	50	50	50	50	50
	Credit Limit	1.50	1.50	1.50	1.50	1.50	1.50	1.50	1.50	1.50	1.50
Macedonia	Tax Rate	2.00	2.00	2.00	-	-	-	-	-	-	-
	Tax Credit	100	100	100	-	-	-	-	-	-	-
	Credit Limit	2.00	2.00	2.00	-	-	-	-	-	-	-
Macedonia/ Northfield Jedd	Tax Rate	2.00	2.00	2.00	-	-	-	-	-	-	-

Continued

# Regional Income Tax Agency

Table of Municipal Income Tax Rates, Credits and Limits – Last Ten Fiscal Years (continued)

		2006	2005	2004	2003	2002	2001	2000	1999	1998	1997
Maineville	Tax Rate	1.00%	1.00%	1.00%	1.00%	1.00%	-	-	-	-	-
	Tax Credit	50	50	50	50	50	-	-	-	-	-
	Credit Limit	1.00	1.00	1.00	1.00	1.00	-	-	-	-	-
Maple Heights	Tax Rate	2.00	2.00	2.00	2.00	2.00	2.00%	2.00%	2.00%	2.00%	2.00%
	Tax Credit	80	80	80	80	80	80	80	80	80	80
	Credit Limit	2.00	2.00	2.00	2.00	2.00	2.00	2.00	2.00	2.00	2.00
Martins Ferry	Tax Rate	0.75	0.75	0.75	0.75	0.75	0.00	0.00	0.00	0.00	0.00
	Tax Credit	100	100	100	100	100	0	0	0	0	0
	Credit Limit	0.75	0.75	0.75	0.75	0.75	0.00	0.00	0.00	0.00	0.00
Marysville	Tax Rate	-	-	1.00	1.00	1.00	-	-	-	-	-
	Tax Credit	-	-	50	50	50	-	-	-	-	-
	Credit Limit	-	-	1.00	1.00	1.00	-	-	-	-	-
Mayfield Heights	Tax Rate	1.00	1.00	1.00	1.00	1.00	1.00	1.00	1.00	1.00	1.00
	Tax Credit	50	50	50	50	50	50	50	50	50	50
	Credit Limit	1.00	1.00	1.00	1.00	1.00	1.00	1.00	1.00	1.00	1.00
Mayfield Village	Tax Rate	1.50	1.50	1.50	1.50	1.50	1.50	1.50	1.50	1.50	1.50
	Tax Credit	100	100	100	100	100	100	100	100	100	100
	Credit Limit	1.50	1.50	1.50	1.50	1.50	1.50	1.50	1.50	1.50	1.50
Mechanics-burg	Tax Rate	1.00	1.00	-	-	-	-	-	-	-	-
	Tax Credit	-	-	-	-	-	-	-	-	-	-
	Credit Limit	1.00	1.00	-	-	-	-	-	-	-	-
Middleburg Heights	Tax Rate	1.75	1.75	1.75	1.75	1.75	1.75	1.75	1.75	1.75	1.00
	Tax Credit	100	100	100	100	100	100	100	100	100	75
	Credit Limit	1.75	1.75	1.75	1.75	1.75	1.75	1.75	1.75	1.75	1.00
Milan	Tax Rate	0.50	0.50	0.50	0.50	0.50	0.50	0.50	0.50	0.50	0.50
	Tax Credit	-	-	-	-	-	-	100	100	100	100
	Credit Limit	0.50	0.50	0.50	0.50	0.50	0.50	0.50	0.50	0.50	0.50
Milford Center	Tax Rate	1.00	1.00	1.00	1.00	1.00	1.00	1.00	1.00	1.00	-
	Tax Credit	50	50	50	50	50	50	50	50	50	-
	Credit Limit	1.00	1.00	1.00	1.00	1.00	1.00	1.00	1.00	1.00	-
Minerva Park	Tax Rate	1.00	1.00	-	-	-	-	-	-	-	-
	Tax Credit	50	50	-	-	-	-	-	-	-	-
	Credit Limit	1.00	1.00	-	-	-	-	-	-	-	-

Continued

# Regional Income Tax Agency

Table of Municipal Income Tax Rates, Credits and Limits – Last Ten Fiscal Years (continued)

		2006	2005	2004	2003	2002	2001	2000	1999	1998	1997
Mogadore	Tax Rate	2.00%	2.00%	2.00%	2.00%	2.00%	2.00%	2.00%	1.50%	1.50%	1.50%
	Tax Credit	100	100	100	100	100	100	100	100	100	100
	Credit Limit	2.00	2.00	2.00	2.00	2.00	2.00	2.00	1.50	1.50	1.50
Moreland Hills	Tax Rate	1.00	1.00	1.00	1.00	1.00	1.00	1.00	1.00	1.00	1.00
	Tax Credit	-	-	-	-	-	-	-	-	-	0/12.5
	Credit Limit	1.00	1.00	1.00	1.00	1.00	1.00	1.00	1.00	1.00	1.00
Mount Gilead	Tax Rate	-	-	-	1.00	1.00	1.00	1.00	1.00	-	-
	Tax Credit	-	-	-	100	100	100	100	100	-	-
	Credit Limit	-	-	-	1.00	1.00	1.00	1.00	1.00	-	-
Mount Sterling	Tax Rate	1.00	1.00	1.00	1.00	1.00	1.00	1.00	1.00	1.00	1.00
	Tax Credit	-	-	-	-	-	-	-	-	-	-
	Credit Limit	1.00	1.00	1.00	1.00	1.00	1.00	1.00	1.00	1.00	1.00
New Albany	Tax Rate	2.00	2.00	2.00	2.00	1.00	1.00	1.00	1.00	1.00	1.00
	Tax Credit	100	100	100	100	100	50	50	50	50	50
	Credit Limit	2.00	2.00	2.00	2.00	1.00	1.00	1.00	1.00	1.00	1.00
New Bloomington	Tax Rate	1.00	1.00	1.00	1.00	1.00	-	-	-	-	-
	Tax Credit	50	50	50	50	50	-	-	-	-	-
	Credit Limit	1.00	1.00	1.00	1.00	1.00	-	-	-	-	-
New Waterford	Tax Rate	1.00	-	-	-	-	-	-	-	-	-
	Tax Credit	50	-	-	-	-	-	-	-	-	-
	Credit Limit	1.00	-	-	-	-	-	-	-	-	-
Newburgh Heights	Tax Rate	2.00	2.00	2.00	2.00	2.00	2.00	1.50	1.50	1.50	1.50
	Tax Credit	60	60	60	60	60	60	-	-	-	-
	Credit Limit	1.00	1.00	1.00	1.00	1.00	1.00	1.00	1.00	1.00	1.00
Newtown	Tax Rate	1.00	1.00	1.00	1.00	1.00	1.00	1.00	1.00	1.00	1.00
	Tax Credit	100	100	100	100	100	100	100	100	100	100
	Credit Limit	1.00	1.00	1.00	1.00	1.00	1.00	1.00	1.00	1.00	1.00
North Lewisburg	Tax Rate	1.00	1.00	1.00	1.00	1.00	1.00	1.00	1.00	1.00	1.00
	Tax Credit	50	50	50	50	50	50	50	50	50	50
	Credit Limit	1.00	1.00	1.00	1.00	1.00	1.00	1.00	1.00	1.00	1.00

Continued

# Regional Income Tax Agency

Table of Municipal Income Tax Rates, Credits and Limits – Last Ten Fiscal Years (continued)

		2006	2005	2004	2003	2002	2001	2000	1999	1998	1997
North											
Olmsted	Tax Rate	2.00%	2.00%	2.00%	2.00%	2.00%	2.00%	2.00%	2.00%	2.00%	2.00%
	Tax Credit	100	100	100	100	100	100	100	100	100	100
	Credit Limit	2.00	2.00	2.00	2.00	2.00	2.00	2.00	2.00	2.00	2.00
North											
Royalton	Tax Rate	1.00	1.00	1.00	1.00	1.00	1.00	1.00	-	-	-
	Tax Credit	25	25	25	25	25	25	25	-	-	-
	Credit Limit	1.00	1.00	1.00	1.00	1.00	1.00	1.00	-	-	-
Oakwood											
Village	Tax Rate	2.00	2.00	2.00	2.00	2.00	2.00	2.00	2.00	2.00	2.00
	Tax Credit	100	100	100	100	100	100	100	100	100	100
	Credit Limit	2.00	2.00	2.00	2.00	2.00	2.00	2.00	2.00	2.00	2.00
Oberlin											
	Tax Rate	1.90	1.90	1.90	1.90	1.90	-	-	-	-	-
	Tax Credit	100	100	100	100	100	-	-	-	-	-
	Credit Limit	1.90	1.90	1.90	1.90	1.90	-	-	-	-	-
Olmsted											
Falls	Tax Rate	1.50	1.50	1.50	1.50	1.50	1.50	1.50	1.50	1.50	1.50
	Tax Credit	50	50	50	50	50	50	50	50	50	50
	Credit Limit	1.50	1.50	1.50	1.50	1.50	1.50	1.50	1.50	1.50	1.50
Orange											
	Tax Rate	2.00	2.00	2.00	2.00	2.00	2.00	2.00	2.00	2.00	2.00
	Tax Credit	60	60	60	60	60	60	60	60	60	60
	Credit Limit	1.50	1.50	1.50	1.50	1.50	1.50	1.50	1.50	1.50	1.50
Orange											
Chagrin											
Highland Jedd	Tax Rate	2.00	2.00	2.00	2.00	2.00	2.00	2.00	-	-	-
	Tax Rate	1.00	1.00	2.00	2.00	1.00	1.00	1.00	1.00	1.00	1.00
	Tax Credit	100	100	100	100	100	100	100	100	100	100
Ottawa	Credit Limit	1.00	1.00	1.00	1.00	1.00	1.00	1.00	1.00	1.00	1.00
	Tax Rate	1.00	1.00	1.00	1.00	1.00	1.00	1.00	1.00	1.00	1.00
	Tax Credit	50	50	50	50	50	50	50	50	50	50
Pepper Pike	Credit Limit	1.00	1.00	1.00	1.00	1.00	1.00	1.00	1.00	1.00	1.00
	Tax Rate	1.00	1.00	1.00	1.00	1.00	1.00	1.00	1.00	1.00	1.00
	Tax Credit	50	50	50	50	50	50	50	50	50	50
Piketon	Credit Limit	1.00	1.00	1.00	1.00	1.00	1.00	1.00	1.00	1.00	1.00
	Tax Rate	1.00	-	-	-	-	-	-	-	-	-
	Tax Credit	50	-	-	-	-	-	-	-	-	-
Plain City	Credit Limit	1.00	-	-	-	-	-	-	-	-	-
	Tax Rate	1.00	1.00	1.00	1.00	1.00	1.00	1.00	1.00	1.00	1.00
	Tax Credit	-	-	-	-	-	-	-	-	-	-
	Credit Limit	1.00	1.00	1.00	1.00	1.00	1.00	1.00	1.00	1.00	1.00

Continued

# Regional Income Tax Agency

Table of Municipal Income Tax Rates, Credits and Limits – Last Ten Fiscal Years (continued)

		2006	2005	2004	2003	2002	2001	2000	1999	1998	1997
Plymouth	Tax Rate	0.50%	0.50%	0.50%	0.50%	0.50%	0.50%	-	-	-	-
	Tax Credit	-	-	-	-	-	-	-	-	-	-
	Credit Limit	0.50	0.50	0.50	0.50	0.50	0.50	-	-	-	-
Powell	Tax Rate	0.75	0.75	0.75	0.75	0.75	0.75	0.75%	0.75%	0.75%	0.75%
	Tax Credit	100	100	100	100	100	100	100	100	100	100
	Credit Limit	0.25	0.25	0.25	0.25	0.25	0.25	0.25	0.25	0.25	0.25
Powhatan Point	Tax Rate	0.75	-	-	-	-	-	-	-	-	-
	Tax Credit	100	-	-	-	-	-	-	-	-	-
	Credit Limit	0.75	-	-	-	-	-	-	-	-	-
Reminderville	Tax Rate	1.50	1.50	1.50	1.50	1.50	1.50	1.50	1.50	1.25	1.00
	Tax Credit	-	-	-	-	-	-	25	25	25	25
	Credit Limit	1.50	1.50	1.50	1.50	1.50	1.50	1.50	1.50	1.25	-
Reminderville/ Twinsburg											
Jedd	Tax Rate	1.50	1.50	1.50	1.50	-	-	-	-	-	-
Reynoldsburg	Tax Rate	1.50	1.50	1.50	1.50	1.50	1.50	1.50	1.50	1.50	1.50
	Tax Credit	100	100	100	100	100	100	100	100	100	100
	Credit Limit	1.50	1.50	1.50	1.50	1.50	1.50	1.50	1.50	1.50	1.50
Richmond Heights	Tax Rate	2.00	2.00	2.00	2.00	2.00	2.00	2.00	2.00	2.00	2.00
	Tax Credit	100	100	100	100	100	100	100	100	100	100
	Credit Limit	2.00	2.00	2.00	2.00	2.00	2.00	2.00	2.00	2.00	2.00
Richwood	Tax Rate	1.00	1.00	1.00	0.50	0.50	0.50	0.50	0.50	0.50	0.50
	Tax Credit	-	-	-	25	25	25	25	25	25	25
	Credit Limit	1.00	1.00	1.00	1.00	1.00	1.00	1.00	1.00	1.00	1.00
Ridgeway	Tax Rate	0.50	0.50	0.50	0.50	0.50	-	-	-	-	-
	Tax Credit	-	-	-	-	-	-	-	-	-	-
	Credit Limit	0.50	0.50	0.50	0.50	0.50	-	-	-	-	-
Riverside	Tax Rate	1.50	1.50	1.50	1.50	1.50	1.50	1.25	1.00	1.00	1.00
	Tax Credit	100	100	100	100	100	100	100	100	100	100
	Credit Limit	1.50	1.50	1.50	1.50	1.50	1.50	1.25	1.00	1.00	1.00
Sabina	Tax Rate	1.00	1.00	0/0.50	1.00	1.00	-	-	-	-	-
	Tax Credit	100	100	-	50/0	50	-	-	-	-	-
	Credit Limit	1.00	1.00	0.50	1.00/0	1.00	-	-	-	-	-

Continued

# Regional Income Tax Agency

Table of Municipal Income Tax Rates, Credits and Limits – Last Ten Fiscal Years (continued)

		2006	2005	2004	2003	2002	2001	2000	1999	1998	1997
Saint Paris	Tax Rate	1.00%	1.00%	1.00%	1.00%	1.00%	1.00%	1.00%	1.00%	1.00%	1.00%
	Tax Credit	100	100	100	100	100	100	100	100	100	100
	Credit Limit	1.00	1.00	1.00	1.00	1.00	1.00	1.00	1.00	1.00	1.00
Salineville	Credit Limit	1.00	1.00	1.00	1.00	1.00	1.00	1.00	1.00	1.00	1.00
	Tax Credit	50	50	50	50	50	50	50	50	50	50
	Credit Limit	1.00	1.00	1.00	1.00	1.00	1.00	1.00	1.00	1.00	1.00
Sandusky	Tax Rate	1.00	1.00	1.00	1.00	-	-	-	-	-	-
	Tax Credit	-	50	50	50	-	-	-	-	-	-
	Credit Limit	1.00	1.00	1.00	1.00	-	-	-	-	-	-
Seven Hills	Tax Rate	2.00	2.00	2.00	2.00	2.00	2.00	2.00	2.00	2.00	2.00
	Tax Credit	100	100	100	100	100	100	100	100	100	100
	Credit Limit	1.10	1.10	1.10	1.10	1.10	1.10	1.10	1.10	1.10	1.10
Shaker Heights	Tax Rate	1.75	1.75	1.75	1.75	1.75	1.75	1.75	1.75	1.75	1.75
	Tax Credit	50	50	50	50	50	50	50	50	50	50
	Credit Limit	1.00	1.00	1.00	1.00	1.00	1.00	1.00	1.00	1.00	1.00
Shawnee Hills	Tax Rate	2.00	2.00	2.00	2.00	2.00	2.00	2.00	2.00	2.00	2.00
	Tax Credit	100	100	100	100	100	100	100	100	100	100
	Credit Limit	1.75	1.75	1.75	1.75	1.75	1.75	1.75	1.75	1.75	1.75
Sheffield Lake	Tax Rate	1.25/1.50	1.25	1.25	1.25	-	-	-	-	-	-
	Tax Credit	50	50	50	50	-	-	-	-	-	-
	Credit Limit	1.00	1.00	1.00	1.00	-	-	-	-	-	-
Sheffield Village	Tax Rate	1.50	1.50	1.50	1.50	1.00/1.50	1.00	1.00	1.00	1.00	1.00
	Tax Credit	100	100	100	100	100	100	100	100	100	100
	Credit Limit	1.50	1.50	1.50	1.50	1.00/1.50	1.00	1.00	1.00	1.00	1.00
Sherwood	Tax Rate	1.00	1.00	1.00	-	-	-	-	-	-	-
	Tax Credit	100	100	100	-	-	-	-	-	-	-
	Credit Limit	1.00	1.00	1.00	-	-	-	-	-	-	-
Silver Lake	Tax Rate	2.00	2.00	2.00	2.00	2.00	2.00	2.00	2.00	2.00	2.00
	Tax Credit	100	100	100	100	100	100	100	100	100	100
	Credit Limit	2.00	2.00	2.00	2.00	2.00	2.00	2.00	2.00	2.00	2.00
South Euclid	Tax Rate	2.00	1.50	1.50	1.50	1.50	1.50	1.50	1.50	1.50	1.50
	Tax Credit	75	75	75	75	75	75	75	75	75	75
	Credit Limit	1.00	1.00	1.00	1.00	1.00	1.00	1.00	1.00	1.00	1.00

Continued

# Regional Income Tax Agency

Table of Municipal Income Tax Rates, Credits and Limits – Last Ten Fiscal Years (continued)

		2006	2005	2004	2003	2002	2001	2000	1999	1998	1997
South Solon	Tax Rate	1.00%	1.00%	1.00%	1.00%	1.00%	1.00%	1.00%	1.00%	1.00%	0.50%
	Tax Credit	-	-	-	-	-	-	-	-	-	-
	Credit Limit	1.00	1.00	1.00	1.00	1.00	1.00	1.00	1.00	1.00	0.50
Steubenville	Tax Rate	2.00	2.00	2.00	2.00	2.00	2.00	2.00	2.00	2.00	2.00
	Tax Credit	100	100	100	100	100	100	100	100	100	100
	Credit Limit	2.00	2.00	2.00	2.00	2.00	2.00	2.00	2.00	2.00	2.00
Streetsboro	Tax Rate	1.00	1.00	1.00	1.00	1.00	1.00	1.00	1.00	1.00	1.00
	Tax Credit	-	-	-	-	-	-	-	-	-	-
	Credit Limit	1.00	1.00	1.00	1.00	1.00	1.00	1.00	1.00	1.00	1.00
Strongsville	Tax Rate	2.00	2.00	2.00	2.00	2.00	2.00	2.00	2.00	2.00	2.00
	Tax Credit	75	75	100/75	100	100	100	100	100	100	100
	Credit Limit	2.00	2.00	2.00	2.00	2.00	2.00	2.00	2.00	2.00	2.00
Sunbury	Tax Rate	1.00	1.00	1.00	1.00	1.00	1.00	1.00	2.00	-	-
	Tax Credit	-	-	-	-	50	50	50	100	-	-
	Credit Limit	1.00	1.00	1.00	1.00	1.00	1.00	1.00	2.00	-	-
Tontogany	Tax Rate	1.00	-	-	-	-	-	-	-	-	-
	Tax Credit	100	-	-	-	-	-	-	-	-	-
	Credit Limit	1.00	-	-	-	-	-	-	-	-	-
Toronto	Tax Rate	2.00	1.50	1.50	1.50	1.50	1.50	1.50	1.50	1.50	1.50
	Tax Credit	100	100	100	100	100	100	100	100	100	100
	Credit Limit	2.00	1.50	1.50	1.50	1.50	1.50	1.50	1.50	1.50	1.50
Uhrichsville	Tax Rate	1.75	-	-	-	-	-	-	-	-	-
	Tax Credit	100	-	-	-	-	-	-	-	-	-
	Credit Limit	1.75	-	-	-	-	-	-	-	-	-
University Heights	Tax Rate	1.50	1.50	1.50	1.50	1.50	1.50	1.50	1.50	1.50	1.50
	Tax Credit	-	-	50/0	50	50	50	50	50	50	50
	Credit Limit	1.00	1.00	1.00	1.00	1.00	1.00	1.00	1.00	1.00	1.00
Upper Arlington	Tax Rate	2.00	2.00	2.00	2.00	2.00	2.00	2.00	2.00	2.00	2.00
	Tax Credit	100	100	100	100	100	100	100	100	100	100
	Credit Limit	2.00	2.00	2.00	2.00	2.00	2.00	2.00	2.00	2.00	2.00
Urbancrest	Tax Rate	2.00	2.00	2.00	2.00	-	-	-	-	-	-
	Tax Credit	100	100	100	100	-	-	-	-	-	-
	Credit Limit	2.00	2.00	2.00	2.00	-	-	-	-	-	-

Continued

# Regional Income Tax Agency

Table of Municipal Income Tax Rates, Credits and Limits – Last Ten Fiscal Years (continued)

		2006	2005	2004	2003	2002	2001	2000	1999	1998	1997
Valley View	Tax Rate	2.00%	2.00%	2.00%	2.00%	2.00%	2.00%	2.00%	2.00%	2.00%	2.00%
	Tax Credit	100	100	100	100	100	100	100	100	100	100
	Credit Limit	2.00	2.00	2.00	2.00	2.00	2.00	2.00	2.00	2.00	2.00
Vermilion	Tax Rate	1.00	1.00	1.00	1.00	1.00	1.00	1.00	1.00	-	-
	Tax Credit	100	100	100	100	100	100	100	100	-	-
	Credit Limit	1.00	1.00	1.00	1.00	1.00	1.00	1.00	1.00	-	-
Wakeman	Tax Rate	1.00	1.00	1.00/0/1.00	1.00	1.00	1.00	1.00	1.00	1.00	1.00
	Tax Credit	50	50	50/0/50	50	50	50/0/50	50	50	50	
	Credit Limit	1.00	1.00	1.00/0/1.00	1.00	1.00	1.00	1.00	1.00	1.00/0/1.00	
Walton Hills	Tax Rate	2.00	2.00	2.00	2.00	1.00	1.00	1.00	1.00	1.00	1.00
	Tax Credit	100	100	100	100	100	100	100	100	100	100
	Credit Limit	2.00	2.00	2.00	2.00	1.00/2.00	1.00	1.00	1.00	1.00	1.00
Wellston	Tax Rate	0.75	0.75	0.75	0.75	0.75	0.75	-	-	-	-
	Tax Credit	100	100	100	100	100	100	-	-	-	-
	Credit Limit	0.75	0.75	0.75	0.75	0.75	0.75	-	-	-	-
Wellsville	Tax Rate	1.00	1.00	1.00	-	-	-	-	-	-	-
	Tax Credit	-	-	-	-	-	-	-	-	-	-
	Credit Limit	1.00	1.00	1.00	-	-	-	-	-	-	-
West Elkton	Tax Rate	1.00	-	-	-	-	-	-	-	-	-
	Tax Credit	-	-	-	-	-	-	-	-	-	-
	Credit Limit	1.00	-	-	-	-	-	-	-	-	-
Westlake	Tax Rate	1.50	1.50	1.50	1.50	1.50	1.50	1.50	1.50	1.50	1.50
	Tax Credit	100	100	100	100	100	100	100	100	100	100
	Credit Limit	1.50	1.50	1.50	1.50	1.50	1.50	1.50	1.50	1.50	1.50
Willowick	Tax Rate	2.00	2.00	2.00	2.00	2.00	2.00	2.00	2.00	2.00	2.00
	Tax Credit	87.50	87.5	87.5	87.5	87.5	87.5	87.5	87.5	87.5	87.5
	Credit Limit	2.00	2.00	2.00	2.00	2.00	2.00	2.00	2.00	2.00	2.00
Wintersville	Tax Rate	1.00	1.00	1.00	1.00	1.00	1.00	1.00	1.00	1.00	1.00
	Tax Credit	100	100	100	100	100	100	100	100	100	100
	Credit Limit	1.00	1.00	1.00	1.00	1.00	1.00	1.00	1.00	1.00	1.00
Woodmere	Tax Rate	2.00	2.00	2.00	2.00	2.00	2.00	2.00	2.00	2.00	2.00
	Tax Credit	75	75	75	75	75	75	75	75	75	75
	Credit Limit	1.00	1.00	1.00	1.00	1.00	1.00	1.00	1.00	1.00	1.00

Continued



# Regional Income Tax Agency

Table of Municipal Income Tax Rates, Credits and Limits – Last Ten Fiscal Years (continued)

		2006	2005	2004	2003	2002	2001	2000	1999	1998	1997
Woodstock	Tax Rate	1.00%	-	-	-	-	-	-	-	-	-
	Tax Credit	-	-	-	-	-	-	-	-	-	-
	Credit Limit	1.00	-	-	-	-	-	-	-	-	-
Worthington	Tax Rate	2.00	2.00%	2.00%	1.65%	1.65%	-	-	-	-	-
	Tax Credit	100	100	75	100	100	-	-	-	-	-
	Credit Limit	2.00	2.00	2.00	1.65	1.65	-	-	-	-	-
Yellow Springs	Tax Rate	1.50	1.50	1.50	1.50	-	-	-	-	-	-
	Tax Credit	100	100	100	100	-	-	-	-	-	-
	Credit Limit	1.50	1.50	1.50	1.50	-	-	-	-	-	-
Youngstown	Tax Rate	2.75	-	-	-	-	-	-	-	-	-
	Tax Credit	100	-	-	-	-	-	-	-	-	-
	Credit Limit	2.75	-	-	-	-	-	-	-	-	-

## Regional Income Tax Agency

Ratio of Outstanding Debt to Members' Tax Collections and Population – Last Seven Fiscal Years

---

<u>Year</u>	<u>CCPA Lease #1</u>	<u>NCLC</u>	<u>CCPA Lease #2</u>	<u>Unamortized Premium</u>	<u>Total Debt</u>	<u>R.I.T.A. Collections</u>	<u>Percentage of Collections</u>	<u>R.I.T.A. Member Total Population</u>	<u>Per Capita</u>
2006	\$ 2,771,667	\$ 0	\$ 20,613,498	\$ 566,588	\$ 23,951,753	\$ 622,025,867	3.85 %	1,364,507	\$ 18
2005	3,228,334	0	20,868,001	618,416	24,714,751	541,375,463	4.57	1,364,507	18
2004	3,736,667	18,580,000	20,990,000	672,747	43,979,414	492,978,422	8.92	1,364,507	32
2003	4,174,167	18,500,000	0	0	22,674,167	471,667,088	4.81	1,364,507	17
2002	4,581,667	17,500,000	0	0	22,081,667	419,885,152	5.26	1,364,507	16
2001	4,968,333	17,500,000	0	0	22,468,333	411,035,925	5.47	1,364,507	16
2000	4,770,048	0	0	0	4,770,048	386,966,066	1.23	1,364,507	3

**Report on Internal Control over Financial Reporting and on  
Compliance and Other Matters Based on an Audit of Financial Statements  
Performed in Accordance with *Government Auditing Standards***

Regional Income Tax Agency  
Brecksville, Ohio

We have audited the financial statements of the business-type activities and the aggregate remaining fund information of the Regional Income Tax Agency (“R.I.T.A.”) as of and for the year ended December 31, 2006, which collectively comprise R.I.T.A.’s basic financial statements and have issued our report thereon dated June 15, 2007, wherein we noted R.I.T.A. adopted *Government Accounting Standards Board Statements No. 44, 46, and 47*. We conducted our audit in accordance with auditing standards generally accepted in the United States of America and the standards applicable to financial audits contained in *Government Auditing Standards*, issued by the Comptroller General of the United States.

**Internal Control over Financial Reporting**

In planning and performing our audit, we considered R.I.T.A.’s internal control over financial reporting as a basis for designing our auditing procedures for the purpose of expressing our opinions on the financial statements, but not for the purpose of expressing an opinion on the effectiveness of R.I.T.A.’s internal control over financial reporting. Accordingly, we do not express an opinion on the effectiveness of R.I.T.A.’s internal control over financial reporting.

A control deficiency exists when the design or operation of a control does not allow management or employees, in the normal course of performing their assigned functions, to prevent or detect misstatements on a timely basis. A significant deficiency is a control deficiency, or combination of control deficiencies, that adversely affects R.I.T.A.’s ability to initiate, authorize, record, process, or report financial data reliably in accordance with generally accepted accounting principles such that there is more than a remote likelihood that a misstatement of R.I.T.A.’s financial statements that is more than inconsequential will not be prevented or detected by R.I.T.A.’s internal control.

A material weakness is a significant deficiency, or combination of significant deficiencies, that results in more than a remote likelihood that a material misstatement of the financial statements will not be prevented or detected by the R.I.T.A.’s internal control.

Our consideration of the internal control over financial reporting was for the limited purpose described in the first paragraph of this section and would not necessarily identify all deficiencies in internal control that might be significant deficiencies or material weaknesses. We did not identify any deficiencies in internal control over financial reporting that we consider to be material weaknesses, as defined above.

Regional Income Tax Agency  
Brecksville, Ohio

### **Compliance and Other Matters**

As part of obtaining reasonable assurance about whether R.I.T.A.'s financial statements are free of material misstatement, we performed tests of its compliance with certain provisions of laws, regulations, contracts, and grant agreements, noncompliance with which could have a direct and material effect on the determination of financial statement amounts. However, providing an opinion on compliance with those provisions was not an objective of our audit, and accordingly, we do not express such an opinion. The results of our tests disclosed no instances of noncompliance or other matters that are required to be reported under *Government Auditing Standards*.

This report is intended solely for the information and use of management, members of the Regional Income Tax Agency, Board of Trustees, and the Auditor of State and is not intended to be and should not be used by anyone other than these specified parties.

*Cini & Panichi, Inc.*

Cleveland, Ohio  
June 15, 2007



**Mary Taylor, CPA**  
Auditor of State

**REGIONAL INCOME TAX AGENCY**

**CUYAHOGA COUNTY**

**CLERK'S CERTIFICATION**

**This is a true and correct copy of the report which is required to be filed in the Office of the Auditor of State pursuant to Section 117.26, Revised Code, and which is filed in Columbus, Ohio.**

*Susan Babbitt*

**CLERK OF THE BUREAU**

**CERTIFIED  
JULY 26, 2007**